

BIDDING DOCUMENT FOR PROCUREMENT OF CIVIL WORKS

(NATIONAL COMPETITIVE BIDDING)



Name of work:- Surajkund Ranital G.O.V. (Pumping) Water Supply Scheme Phase II of Block Narendra Nagar - Construction of 1 No. 100 KL Capacity RCC Sump Reservoir, 1 No. 12 m x 7 m x 4.0 m size Pump House (With Guard Room), 2 Nos. Type I Staff Quarter at IPS-I near Lodashi Village, Supplying, carting, laying & jointing of Feeder Main consisting of 3300 m of 32 mm to 25 mm dia. GI (M/H) Pipeline by socket, Construction of 2 Nos. of 35 KL to 15 KL Capacity RCC Service Reservoir and all other civil appurtenant works including Survey, Design / Checking of design of different Civil Structures / Pipeline etc. complete.

Package No. :- NRDWP / SR- 2

Programme :- National Rural Drinking Water Programme (NRDWP)

**EXECUTIVE ENGINEER,
CONSTRUCTION DIVISION,
UTTARAKHAND PEYJAL NIGAM,
MUNI KI RETI**

INDEX

Section No.	Description	Page No.
I	Bid Reference	3 to 4
II	Invitation for Bids (IFB)	5 to 8
III	Instruction to Bidders (ITB)	9 to 32
IV	General Conditions of Contract (GCC)	33 to 64
V	Specifications	65 to 221
VI	Drawings	222 to 238
VII	Contract Data	239 to 244
VIII	Qualification Information, Declaration and Other Forms	245 to 269
IX	Securities and Other Forms	270 to 277
X	Form of Bid	278 to 280
XI	Bill of Quantities	281 to 290

SECTION - I

BID

REFERENCE

OFFICE OF THE EXECUTIVE ENGINEER,
CONSTRUCTION DIVISION, UTTARAKHAND PEYJAL NIGAM,
MUNI KI RETI (T.G.)

NATIONAL COMPETITIVE BIDDING

1. **Tender Notice (IFB) No.** : 3275 / 701 / 67, Dated 25-10-2012
2. **Bid No.** : NRDWP / SR- 2
3. **Name of Work** : **Surajkund Ranital G.O.V. (Pumping) Water Supply Scheme Phase II of Block Narendra Nagar** - Construction of 1 No. 100 KL Capacity RCC Sump Reservoir, 1 No. 12 m x 7 m x 4.0 m size Pump House (With Guard Room), 2 Nos. Type I Staff Quarter at IPS-I near Lodashi Village, Supplying, carting, laying & jointing of Feeder Main consisting of 3300 m of 32 mm to 25 mm dia. GI (M/H) Pipeline by socket, Construction of 2 Nos. of 35 KL to 15 KL Capacity RCC Service Reservoir and all other civil appurtenant works including Survey, Design / Checking of design of different Civil Structures / Pipeline etc. complete.
4. **Under the Programme** : National Rural Drinking Water Programme (NRDWP)
5. **Under the Jurisdiction of** : Executive Engineer, Construction Division, Uttarakhand Peyjal Nigam, Muni Ki Reti
6. **Period of Sale of Bidding Document** : Date - 30.10.2012 Time – 10:00 Hrs. to Date - 22.11.2012 Time – 17:00 Hrs.
7. **Places of Sale of Bid Document** : Any of the following -
 - a) Executive Engineer, Construction Division, Muni Ki Reti (District- Tehri Garhwal)
 - b) Executive Engineer, Construction Division, Haridwar (District- Haridwar)
8. **Time, Date and Place of Pre – Bid Conference** : Date –x.....
Time–x.....
Office of the Executive Engineer, Construction Division, Uttarakhand Peyjal Nigam, Muni Ki Reti
9. **Last date and time for receipt of Bids** : Date – 23.11.2012
Time – 15:00 hours
10. **Place of Receipt of Bids** : Any of the Offices mentioned in S.No. 7 (a) & (b) above.
11. **Time and Date of Opening Bids** : Date – 24.11.2012
Time – 12:00 hours
12. **Place of Opening of Bids** : Office of the Superintending Engineer, Construction Circle, Uttarakhand Peyjal Nigam, New Tehri
13. **Officer Inviting Bid** : Executive Engineer, Construction Division, Uttarakhand Peyjal Nigam, Muni Ki Reti

SECTION - II

INVITATION FOR BIDS (IFB)

OFFICE OF THE EXECUTIVE ENGINEER,
CONSTRUCTION DIVISION, UTTARAKHAND PEYJAL NIGAM,
MUNI KI RETI (DISTRICT- TEHRI GARHWAL)

Letter No. 3275 / 701 / 67 Dt. 25.10.12

NATIONAL COMPETITIVE BIDDING

On behalf of the Chairman, Uttarakhand Peyjal Nigam (Uttarakhand Peyjal Sansadhan Vikas Evam Nirman Nigam), Dehradun sealed tenders in **Single Bid System**, on item rate contract basis (inclusive of all material), are invited for the construction of following works in District Tehri Garhwal (Uttarakhand) from technically and financially capable bidders upto 15:00 hours on prescribed date in the offices mentioned in terms and conditions below, which shall be opened on the next day in the office of the Superintending Engineer, Construction Circle, Uttarakhand Peyjal Nigam, New Tehri at 12:00 hours by the designated Tender Opening Committee in the presence of intending bidders or their authorized representatives.

Package No.	Name of work	Bid Security (Earnest Money) (₹ Lacs)	Date of Receipt of bids	Date of opening of bids	Cost of bid document (₹)	Period of completion of works
SR	Surajkund Ranital G.O.V. (Pumping) Water Supply Scheme Phase II of Block Narendra Nagar					
SR-1	Construction of 1 No. 700 KL Capacity RCC Raw Water Sump Reservoir (Open at Top), 1 No. 120 KL Capacity RCC Clear Water Sump Reservoir & 1 No. 12 m x 7 m x 3.5 m size Pump House (With Guard Room) at MPS near Gular Village and all other civil appurtenant works including Survey, Design / Checking of design of different Civil Structures / Pipeline etc. complete.	1.00	23.11.2012	24.11.2012	5000.00 + 13.5% Trade Tax	12 Months

SR-2	Construction of 1 No. 100 KL Capacity RCC Sump Reservoir, 1 No. 12 m x 7 m x 3.5 m size Pump House (With Guard Room), 2 Nos. Type I Staff Quarter at IPS-I near Lodashi Village, Supplying, carting, laying & jointing of Feeder Main consisting of 3300 m of 32 mm to 25 mm dia. GI (M/H) Pipeline by socketing, Construction of 2 Nos. of 35 KL to 15 KL Capacity RCC Service Reservoir and all other civil appurtenant works including Survey, Design / Checking of design of different Civil Structures / Pipeline etc. complete.	1.50	23.11.2012	24.11.2012	5000.00 + 13.5% Trade Tax	12 Months
------	---	------	------------	------------	---------------------------	-----------

Terms and Conditions:-

1. Bid documents can be purchased by cash payment on any working day between **30.10.2012 at 10:00 hours to 22.11.2012 at 17:00 hours** from the following offices of Uttarakhand Peyjal Nigam:-
 - a) Executive Engineer, Construction Division, Muni Ki Reti (District- Tehri Garhwal)
 - b) Executive Engineer, Construction Division, Haridwar (District- Haridwar)

Tender documents obtained from above offices can be submitted in any of the above offices by the date and time specified above. For example, the tender documents obtained from office (a) can be submitted in office (b) as well.
2. Tenders documents can also be downloaded from Website **<http://www.peyjal.uk.gov.in>** and the requisite fee shall be paid by demand draft in favor of the Executive Engineer, Construction Division, Uttarakhand Peyjal Nigam, Muni Ki Reti payable at Muni Ki Reti along with submission of tenders in a separate envelope marked "COST OF TENDER FORM", without which the submitted tender will not be entertained.
3. Bids must accompany the necessary Bid Security (Earnest Money) in the form of FDR or NSC issued by any Public Sector (SBI & Nationalized) / Scheduled Banks or Indian Post Offices respectively, with maturity date at least up to 45 days beyond 3 months' validity period of the Bid, pledged in favor of Executive Engineer, Construction Division, Uttarakhand Peyjal Nigam, Muni Ki Reti.
4. The bids shall remain valid for a period not less than 90 days from deadline date of bid submission.

5. Bidders are advised to visit the respective sites before quoting their rates. Once the bids are accepted, no claim whatsoever will be acceptable.
6. During the construction work, the bidder shall give preference to local labour and shall follow the labour laws of Uttarakhand State.
7. Other Terms and Conditions of bidding contained in bid documents can be seen in the Office of the Executive Engineer, Construction Division, Uttarakhand Peyjal Nigam, Muni Ki Reti.

(Imran Ahmad)
Executive Engineer

Letter No. / / Date.

Copy to following for information & necessary action:-

1. Chief Engineer (HQ), Uttarakhand Peyjal Nigam, Dehradun
2. Chief Engineer, Garhwal / Kumaon, Uttarakhand Peyjal Nigam, Pauri / Nainital.
3. Superintending Engineer, Construction Circle, Uttarakhand Peyjal Nigam, New Tehri.
4. Chairman, Zila Panchayat, New Tehri.
5. District Magistrate, New Tehri.
6. General Manager (Appraisal/Planning), Uttarakhand Peyjal Nigam, 11- Mohini Road, Dehradun.
7. All Superintending Engineers, Uttarakhand Peyjal Nigam.
8. All Executive Engineers, Uttarakhand Peyjal Nigam.
9. Director, Information & Public Relation Department, 12 E.C. Road, Dehradun for getting this Tender Notice published in one National English & Hindi News Paper each & in one regional Hindi News Paper having wide circulation all over Uttarakhand.
10. Office Notice Board.

Executive Engineer

SECTION - III

INSTRUCTIONS
TO BIDDERS

(I.T.B)

Section III: Instructions to Bidders

Table of Clauses

A. General	Page No.	D. Submission of Bids	Page No.
1. Scope of Bid	11	19. Sealing and Marking of Bids	24
2. Source of Funds	11	20. Deadline for Submission of Bids	24
3. Eligible Bidders	11	21. Late Bids	25
4. Qualification of Bidder	14	22. Modification & Withdrawal	25
5. One Bid per Bidder & Cost of Bidding	19		
6. Site Visit	19		
7. Advance Payment	19		
B. Bidding Documents		E. Bid Opening and Evaluation	
8. Content of Bidding Documents	19	23. Bid Opening	25
9. Clarification of Bidding Documents	20	24. Process to be Confidential	27
10. Amendment of Bidding Documents	21	25. Clarification of Bids	27
		26. Examination of Bids and Determination of Responsiveness	28
		27. Correction of Errors	28
		28. Currency for Bid Evaluation	29
		29. Evaluation and Comparison	29
C. Preparation of Bids		30. Negotiation with bidders	30
11. Language of Bid	21		
12. Documents Comprising the Bid	21	F. Award of Contract	
13. Bid Prices	22	31. Award Criteria	30
14. Currencies of Bid and Payment	22	32. Employer's Right to Accept any Bid and to Reject any or all Bids	30
15. Bid Validity	22	33. Notification of Award	30
16. Bid Security	23	34. Performance Security	31
		35. Settlement of Disputes	31
17. Alternative Proposals by Bidders	23	36. Corrupt or Fraudulent Practices	31
18. Format and Signing of Bid	23		

A. General

1 Scope of Bid

- 1.1** Construction of works detailed in the table given in IFB (Section -II) under the jurisdiction of the Executive Engineer specified in Bid Reference (Section -I), referred to as “the works” hereafter.
- 1.2** The successful bidder will be expected to complete the works within the intended completion period specified in the IFB (Section -II).
- 1.3** Throughout these documents, the terms “bid” and “tender” and their derivatives (bidder / tenderer, bid / tender, bidding / tendering, etc.) are synonymous.

2 Source of Funds

- 2.1** The Employer has arranged the funds from the budget of Govt. of India / Govt. of Uttarakhand / External Funding Agency under the programme specified in Bid Reference (Section-I).

3 Eligible Bidders

- 3.1** This Invitation for Bids is open to all eligible bidders meeting the eligibility criteria as defined in Sub Cl. 3.5.
- 3.2** All bidders shall provide in Section - VIII (Qualification Information, Declaration and other forms) a statement that the Bidder is not related / associated, nor has been related / associated in the past, directly or indirectly, with the Employer / Consultant or any other entity (as defined in Section-IV under “Definitions”) that has prepared the design, specifications, other documents etc. for this Project / for this Bid and any of the staff engaged in the actual execution of the work. Any bidder found concealing the facts in violation of the above shall automatically be disqualified and all his securities with the department shall stand forfeited.
- 3.3** Government owned enterprises may participate in bidding only if they are legally and financially autonomous, operate under commercial law and are not a dependent agency of the Owner & fulfil all the requirements as described in eligibility criteria for this tender.
- 3.4** The Bidders must not be under a declaration of ineligibility for corrupt and fraudulent practices issued by the Owner through any of its authorities / Engineers in accordance with Sub Cl. 36.1.
- 3.5 Eligibility Criteria**
 - (a) Any Bidder who is presently doing Civil / Electrical & Mechanical works of similar nature through different contract agreements in Central Govt. / Any State Govt. or Central / State Govt. Undertaking Department are eligible to bid. For this purpose, similar nature of work will be considered under the following categories:-

- (i) Water Supply Civil works
- (ii) Water Supply Electrical & Mechanical works
- (iii) Sewer Laying & Appurtenant works
- (iv) Sewage Treatment Plant and Sewage Pumping Stations.
- (v) Hand Pump construction by Rig Machine.
- (vi) Hand Pump construction by Hand Boring.
- (vii) Overhead tanks.

Experience of only the relevant category works will be considered in Sub Cl. 3.5 (d) & (e) given below.

- (b) The bidder is to provide the requisite information in the annexed formats to qualify and determine the eligibility for bidding.
- (c) The bidder should have achieved a minimum annual financial turnover of value not less than **100% of contract value** in any two years (separately) during the last five years for all type of construction works including those categorized in Sub Cl. 3.5 (a) above.
- (d) The bidder, as prime contractor, should have satisfactorily completed in last 5 years at least one similar work of value not less than **70% of contract value** or should have satisfactorily completed at least two similar works of value not less than **40% of contract value** each or should have satisfactorily completed at least three similar works of value not less than **30% of contract value** each.
- (e) The bidder, as prime contractor, should have executed in any one year during the last five years, a minimum of **50% of the quantities** of items of works specified in Contract Data (Section–VII) out of the Bill of Quantities given in Section-XI.
- (f) The Bidder, however, must be registered with the Central Government / Any State Government or Central / State Govt. Undertaking Department as a Prime Contractor. Proof of certificate to this effect is required to be given by the Bidder.
- (g) The Bidder shall have to give an undertaking on a non-judicial stamp paper of ₹ 100.00, in the format prescribed in Sub Cl. 4.2 (y) below, that in case his bid is accepted, he will get himself registered in Uttarakhand Peyjal Nigam in appropriate category within three months of acceptance of his bid, failing which the prescribed cost of Registration Form, Registration Fees and General Security as per departmental Registration Regulations - 2010, will be deducted from his first Running Bill.
- (h) The bidder should have documentary evidence of financial standing equal to **50% of contract value** well substantiated by the balance sheet submitted with Income Tax Return of last 3 years.
- (i) Experience of work required in Sub Cl. 3.5 (d) & (e) above should be under a Central Govt. Department / any State Govt. Department / Central or State Govt. Undertakings.
- (j) Experience certificate for the similar works obtained from any private agency / contractor shall not be considered.

- (k) Availability of necessary equipments and machinery, either owned or leased, as indicated in Contract Data (Section-VII) should be furnished. The bidder shall have to furnish the attested copies of the Cash Memo, RC etc. of the key and critical equipments required for the work as a proof of such owned equipments and machinery. Any cash memo or bill from a non-registered or any unit not licensed for the manufacture of heavy equipment of this nature shall not be considered. In the cash memo so furnished, the details of excise duty paid, C.S.T. paid and proof of transportation by which the equipment transported to the said destination including the proof of payment of State Trade Tax shall also be furnished.
- (l) Bidder will have to furnish the availability of technical staff required for this work, as detailed in Contract Data (Section-VII), with minimum experience specified in implementation / construction of similar works and other key personnel with adequate experience.
- (m) Bidder will have to furnish the availability of Credit Limit equivalent to **3 Months Cash Flow for this tender** from any Public Sector (SBI and Nationalized) / Scheduled bank of value not less than the amount as indicated in Contract Data (Section-VII). The Credit Limit Certificate issued by the bank should not be more than 3 months old. Its Format is attached in Section-VIII.
- (n) Bidders who meet the minimum qualification criteria will be qualified only if their Available Bid Capacity is more than the total bid value. The Available Bid Capacity will be calculated as under:-

$$\text{Assessed Available Bid capacity} = (A \times N \times 2 - B)$$

where

- A = Maximum value of Civil Engineering works executed in any one year during the last five years (updated to the price level of the current financial year) taking into account the completed as well as works in progress.
- N = Number of years prescribed for completion of the works for which bids are invited.
- B = Value (updated to the price level of the current financial year) of existing commitments and on going works to be completed during the next years.

Note: - The statements showing the value of existing commitments and on-going works as well as the stipulated period of completion remaining for each of the works listed in the statement should be countersigned by the Engineer in charge, not below the rank of an Executive Engineer or equivalent.

Escalation factors (to update to the price level of the current financial year) will be as follows:-

<u>Year Before</u>	<u>Multiplying factor</u>
One	1.05
Two	1.16
Three	1.27
Four	1.40
Five	1.54

(o) Even though the bidders meet the above qualifying criteria on the basis of information furnished by them in the bid documents, they will be treated as disqualified if they have:-

- (i) Furnished misleading or false information in the prescribed forms, statements and attachments submitted in proof of the qualification requirements; and/or
- (ii) Record of poor performance such as leaving the works uncompleted, improper completion of contracted works, inordinate delays in completion of works, litigation history, or financial failures etc. and / or
- (iii) Participated in the previous bidding for the same work and had been found guilty of provisions of Sub Cl. 3.5 (o) (i) & (ii) above.

Note: - The Contractor shall have to produce extract copy of the agreements, certificates for the satisfactory execution of the similar type of works in progress and those completed, in support of experience required under Cl. 3.5 (d) & (e) from a competent employer not less than the rank of the Executive Engineer. The year wise detail of quantities of different item of works executed and their value as per their agreements should also be furnished in support of the experience certificate.

4 Qualification of Bidders:-

4.1 All the Bidders shall provide a brief profile of themselves and their partners, if any / the profile of bidding Company along with its Articles of Association / Joint Venture Agreement along with the profile of each participating Firm. They shall also provide a preliminary description of proposed work methods and schedule including necessary drawings and charts, along with other documents required in the formats detailed below.

4.2 Documents required to be submitted for Qualification:-

The bidder shall include the following documents and information with their bids on requisite formats and other details given in Qualification Information Declaration & Other forms (Section-VIII).

- (a) Proof of Registration (class and type) in Central Government / any State Government / Central Govt. or State Government Undertaking Department. In case a partner of bidding Joint Venture is a Pipe Supplier, proof of being its authorized licensee, copies of original documents defining the constitutional or legal status in JV, copy of Memorandum of Articles of participating firms.
- (b) Written Power of Attorney of the authorized signatory of participating firm / lead partner of JV on a non- judicial stamp paper of ₹ 100.00 duly notarized by a Public Notary.
- (c) Joint Venture Agreement on **Form-I** given in Section-VIII on non- judicial stamp paper of ₹ 100.00 Stamp Paper duly notarized in case of bidder being a JV.

- (d) In case the tender is downloaded from departmental website, the requisite fee as mentioned in Tender Notice (IFB) in the form of Demand Draft as required in Condition 2 of IFB (Section-II).
- (e) Bid Security (Earnest Money) mentioned in Tender Notice (IFB) in the form of FDR / NSC as required in condition 3 of IFB (Section-II).
- (f) Affidavit of Bid Validity for 3 months beyond the date of bid opening in **Form-II** given in Section-VIII on ₹ 100.00 Stamp Paper duly notarized.
- (g) Public Sector (SBI & Nationalized) / Scheduled Bank's Credit Limit Certificate of requisite amount on **Form-III** given in Section-VIII. The relevant certificate should not be more than three months old.
- (h) Undertaking on ₹ 100.00 Stamp Paper in **Form-IV** given in Section-VIII, duly notarized, that the decision of the Departmental Tender Committee regarding the acceptance of the bids shall be final and binding on the bidder.
- (i) Affidavit on ₹ 100.00 Stamp Paper on the **Form-V** given in Section-VIII, duly notarized, regarding no relation with persons responsible for technical design & execution of the project/works.
- (j) Affidavit on ₹ 100.00 Stamp Paper on the **Form-VI** given in Section-VIII, duly notarized, regarding no dues or recoveries of IT, CST, State Trade Tax or any other Government taxes & duties pending in connection with works done under any previous employer.
- (k) General Information of bidder in the **Form-VII** given in Section-VIII.
- (l) Information regarding any litigation pending currently or occurred during the last five years regarding the works done under the previous employers, involving the Bidder, other parties concerned, cause of dispute and the amount involved etc. on **Form-VIII** given in Section-VIII.
- (m) Details of Financial Assets for evidence of adequacy of working capital required for proper execution of this contract on **Form-IX** given in Section-VIII.
- (n) Details of Annual Turnover of last 5 years on the **Form-X** given in Section-VIII.
- (o) Experience of work of similar nature, with work wise details, during last 5 years including details of subletting done, if any, on the **Form-XI** given in Section-VIII, and proof of satisfactory completion of works within the designated time as per the contract agreement and the value of the work done within the time frame substantiated by the certificates issued by employers not below the rank of Executive Engineer.
- (p) Details of Physical Quantities of items required in the Contract Data (Section-VII), executed under different agreements by the bidder in last 5 years on **Form-XII** given in Section-VIII, substantiated by the certificates issued by employers not below the rank of Executive Engineer.
- (q) Summary of current contract commitments / works in progress, for which a letter of indent or acceptance has been received by the bidder and also for the contracts under execution/ approaching completion, specifying stages of each on **Form-XIII** given in Section-VIII, along with addresses and contact nos.

of the corresponding employers who may be contacted for further information regarding these contracts.

- (r) Proposal for subcontracting the components of the works included in this tender which the bidder intends to sublet, if any, on **Form-XIV** given in Section-VIII, the aggregate sum of which should not be more than 20 percent of the total Bid Value (*The bidder shall furnish and annex the qualifications and experience of each identified sub-contractor for similar work done during the last 5 years*). No vertical splitting of work for sub-contracting is acceptable.
- (s) Bidder's banker detail of last 2 years on **Form- XV** (Section-VIII).
- (t) Construction Equipment proposed to be deployed for the project and proof of their availability i.e. equipment proposed to be purchased or leased on **Form-XVI** (Section-VIII).
- (u) Key personnel available and proposed to be engaged for management, and supervision of the Project, their qualification and experience on **Form-XVII** (Section-VIII).
- (v) Proposed Site Organization Chart on **Form-XVIII** (Section-VIII).
- (w) The proposed methodology and programme of construction, backed with equipment planning and deployment, duly supported with broad calculations and quality control procedures proposed to be adopted, justifying their capability of execution and completion of the work as per requisite specifications on **Form-XIX** (Section-VIII).
- (x) Declaration-cum-Request regarding customs / excise duty exemption for materials / construction equipment bought for the work on **Form-XX** (Section-VIII).
- (y) An undertaking on a non-judicial stamp paper of ₹ 100.00 on **Form-XXI** to get himself registered in Uttarakhand Peyjal Nigam in appropriate category within three months of acceptance of his bid, in case his bid is accepted
- (z) Audited Profit & Loss Statement, Balance Sheet, Form 16 A, Income Tax Return of last 5 years.

4.3 Joint Venture

Bids from Joint Ventures are acceptable. Bids submitted by a Joint Venture (JV) of not more than three firms / contractors as partners shall comply with the following requirements:

- a) There shall be a Joint Venture Agreement (refer Form-I in Section-VIII) specific for this contract package between the constituent firms, indicating clearly, amongst other things, the proposed distribution of responsibilities, both financial as well as technical, amongst them for execution of the work. For the purpose of this clause, the most experienced partner will be defined as the Lead Partner. A copy of the notarised Joint Venture agreement in accordance with requirements mentioned in the said Form-I, duly signed by the legally authorized signatories of all the partners of the Joint Venture, shall be submitted in original with the tender.

- b) The bid, and in the case of successful bidder, the Form of Agreement etc. of Contract Bond, shall be signed by the Lead Partner and shall be deemed to be legally binding on all the partners in respect of all operative parts of the ensuing Contract inclusive of Agreement of Arbitration, etc.
- c) Lead partner shall be nominated as being the partner-in-charge, and this authorization shall be evidenced by submitting a Power of Attorney signed by the legally authorized signatories of all the partners.
- d) The partner-in-charge shall be authorized to incur liabilities and to receive instructions for and on behalf of all the partners of the Joint Venture, whether jointly or severally. Entire execution of the Contract (including payments) shall be carried out exclusively through the partner-in-charge. A copy of the said authorization shall be furnished with this bid.
- e) All partners of the Joint Venture shall be liable jointly and individually for the execution of the Contract in accordance with the Contract terms & conditions, and a relevant statement to this effect shall be included in the authorization mentioned under sub clause (c) above as well as in the Form of Tender and the Form of Agreement (in case of a successful bidder).
- f) In the event of default by any partner, in the execution of his part of the Contract, the Employer shall be so notified within 30 days by the partner-in-charge, or in the case of the partner-in-charge being the defaulter, by the remaining partner(s) of the Joint Venture. In case of the defaulter being a partner other than the partner-in-charge, the partner-in-charge shall, within 30 days of the said notice, assign the work of the defaulting partner to any other equally competent party acceptable to the Employer to ensure the execution of that part of the Contract, as envisaged at the time of bid. Failure to comply with the above provisions will make the Contractor liable for action by the Employer under the Conditions of Contract. But if the Most Experienced Lead Partner, defined as partner-in-charge defaults, then it shall be construed as default of the Contractor and shall be treated as Breach of Contract under the Conditions of Contract.
- g) Notwithstanding the permission to assigning the responsibilities of the defaulting partner to any other equally competent party acceptable to the Employer as mentioned in sub clause (f) above, all the partners of the Joint Venture will retain the full and undivided responsibility for the performance of their obligations under the Contract and/or for satisfactory completion of the Works.
- h) The bid submitted shall include all the relevant information as required under the provisions of Sub Cl. 4.2 of ITB and furnished separately for each partner.

4.4 If bidder is a Joint Venture, the partners would be limited to three (including lead partner). Joint Venture firm shall jointly and individually responsible for completion of the project. Joint Venture must fulfil the following minimum qualification requirement:-

- (i) The lead partner shall meet not less than 50% of qualification criteria given in Cl. 3.5 (c), (d) & (e) of ITB above and must comply with the provisions of Cl. 3.5 (f) & (g).

- (ii) All the partners jointly shall meet 100% of all qualification criteria given in Cl. 3.5 (a) to (o) of ITB above.
- (iii) In the event the Employer finds the bidder guilty under Cl. 3.5 (o) of ITB above, all of the Joint Venture partners will automatically stand disqualified.
- (iv) Joint Venture Partners shall also provide a certified copy of the Mutual Agreement arrived amongst them regarding distribution of work and roles & responsibilities, undertaking joint and individual liabilities, for the performance of ensuing Contract against this bid.
- (v) The available bid capacity of the JV as required under Cl. 3.5 (n) of ITB above will be applied for all the partners jointly. The total bid capacity available shall be more than estimated contract value.

Note 1 - The bidder / contractor shall submit the proof of all the contract agreements (e.g. copy of acceptance letter, letter of date of start, certificate of work completion etc) for which the payments have been received during the last five years, in support of details given in Form-XI. The details shall be substantiated by the 'Form - 16 A' issued by employer i.e. the certificate of deduction of the tax at source under section 203 of the Income Tax Act 1961. The photocopies of the "Form – 16 A" shall be enclosed duly attested by Public Notary with seal and Notary Stamp thereon. The contractor shall also submit Balance Sheet, Profit & Loss Statement for last 5 years. It is mandatory that the Balance Sheet must be in profit for last 2 years.

Note 2 - In Sub Cl. 3.5 (d) above, similar work means agreements registered during the last five years of value indicated as above & the value of the work executed under the agreement during the above period only. The contractors shall have to produce the list of running works of similar nature, in progress and certificate for their up to date progress and execution of the work satisfactorily. The certificate will be furnished by the employer not less than the rank of the Executive Engineer.

Note 3 - Only the agreements registered during the above period shall be considered. Requisite time of completion of the contract bond and the actual time of completion of the work should also be indicated separately. The detail of payment received for such contract shall be submitted year wise based on form 16 A issued by employer i.e. the certificate of deduction of tax at source under section 203 of the Income Tax Act. 1961. The photocopies of the Form – 16 A shall be enclosed duly attested.

Note 4 - The Contractor shall have to produce extract copy of the agreements, certificates for the satisfactory execution of the similar type of works in progress and those completed from a competent employer not less then the rank of the Executive Engineer. The year wise detail of quantities of different item of works executed and their value as per their agreements should also be furnished in support of the experience certificate.

Note 5 - The Contractor should submit certificates from an officer of Govt. / Semi Govt. / Govt. undertaking indicating therein the names of the works completed, value of works and period during which it is completed. The certificates should have the signature and seal of the officer. In the absence of such certificates, the tender may not be considered.

Note 6 - Contractor has to satisfy the eligibility criteria for technical capability competence as well as for financial capacity and organizational resources.

- Note 7 - The experience certificate from any private contractor or private organization and as a sub contractor to prime contractor shall not be considered while evaluating the bid in compliance to the qualifying criteria.
- Note 8 - The Experience of any bidder who got the awarded work executed by subletting the same in whole or piece to other contractor, shall likely to be disqualified and such experience shall not be considered for the technical qualification.
- Note 9 - The bidder showing T.D.S. deduction in their balance sheet, income tax return shall have to submit details of T.D.S., date of deposition with I.T.D. and copy of challans, thus, submitted, reasons for deduction of T.D.S. and attested copy of the sub agreement made for to this effect is also required to be submitted.
- Note 10- The bidder shall have to submit copies of the income tax return filed and clearance receipts for the last five years. The bidder shall also give an undertaking that the bidding firm or any of its directors or partners have no dues / recovery pending with any government departments that is IT, CST, state trade tax or any other Government dept. taxes and the bidder shall have to submit an affidavit of same on ₹ 100/- (One Hundred only) stamp paper duly notarised for the same.

5 One Bid per Bidder & Cost of Bidding

- 5.1** Each Bidder shall submit only one Bid for a work. In case, a bidder who submits more than one Bid for a work or if a Joint Venture partner is found to have participated in more than one JVs for the same work, it will cause the bids of all such JVs / Bidder disqualified.
- 5.2** The Bidder shall bear all costs associated with the preparation and submission of his Bid. The Employer will, in no case, be responsible or liable for any such costs.

6. Site Visit

- 6.1** The Bidder, at the Bidder's own responsibility, risks and cost, is encouraged to visit and examine the Site of Works and its surroundings and obtain all information that may be necessary for preparing and quoting rates in the Bid and entering into a Contract for construction of the Works. The costs of visiting the Site shall be at the Bidder's own expense.

7. Advance Payment

- 7.1** Advance Payment may be made to the successful contractor, who enters into the agreement with the employer, as per provisions Cl. 51 of General Conditions of Contract (Section-IV).

B. Bidding Documents

8 Content of Bidding Documents

- 8.1** The set of bidding documents comprises the documents listed below and addendum issued in accordance with Clause 10:

Section	Particulars
I	Bid Reference
II	Invitation for Bids (IFB)
III	Instruction to Bidders (ITB)
IV	General Conditions of Contract (GCC)
V	Specifications
VI	Drawings
VII	Contract Data
VIII	Qualification Information, Declaration and Other Forms
IX	Securities and Other Forms
X	Form of Bid
XI	Bill of Quantities

- 8.2** Every applicant bidder shall be issued two sets of bid document and both sets are required to be completed, signed on each page and submitted at the time of bidding. Documents to be furnished by the bidder in compliance to Section-VIII will also be signed by the bidder and annexed with each of them.

- 8.3** The bidder is expected to examine carefully all instructions, terms and conditions of contract, contract data, forms, specifications, bill of quantities, certificates, annexure and drawings etc. in the Bid Document. Failure to comply with the requirements of Bid Documents shall be at the bidder's own risk. Pursuant to Cl. 26 hereof, bids which are not substantially responsive to the requirements of the Bid Documents, shall be rejected.

9 Clarification of Bidding Documents and Pre-bid Meeting

- 9.1** A prospective Bidder requiring any clarification of the bidding documents may notify the Employer in writing or by cable (hereinafter "cable" includes fax and e-mail) at the Employer's address / fax no. / E-mail ID indicated in the invitation to bid. The Employer will respond to any request for clarification which he receives earlier than 15 days prior to the deadline for submission of bids. Copies of the Employer's response will be forwarded to all purchasers of the bidding documents, including a description of the inquiry, but without identifying its source.

9.2 Pre-bid meeting

- 9.2.1.** The bidder or his official representative is invited to attend a pre-bid meeting, which will take place as per time and date as mentioned in Bid Reference.
- 9.2.2** The purpose of the meeting will be to clarify issues and to answer questions on any matter that may be raised by a prospective bidder or his representative at that stage.

- 9.2.3** The bidder is requested to submit any questions in writing or by fax so as to reach the Employer not later than one week before the meeting.
- 9.2.4** Minutes of the meeting, including the text of the questions rose (without identifying the source of the enquiry) and the responses given will be transmitted without delay to all purchasers of the bidding documents. Any modifications of the bidding documents listed in Sub Cl. 8.1, which may become necessary as a result of the pre-bid meeting, shall be made by the Employer exclusively through the issue of an Addendum pursuant to Cl. 10 and not through the minutes of the pre-bid meeting.
- 9.2.5** Non-attendance at the pre-bid meeting will not be a cause for disqualification of a bidder.

10 Amendment of Bidding Documents

- 10.1** Before the deadline for submission of bids, the Employer may modify the bidding documents by issuing addenda.
- 10.2** Any addendum thus issued shall be part of the bidding documents and shall be communicated in writing or by fax to all purchasers of the bidding documents. Prospective bidders shall acknowledge receipt of each addendum by fax to the Employer. The Employer will assume no responsibility for postal delays.
- 10.3** To give prospective bidders reasonable time in which to take an addendum into account in preparing their bids, the Employer may at his discretion, extend, as necessary the deadline for submission of bids, in accordance with Sub Cl. 20.2 below.

C. Preparation of Bids

11 Language of Bid

- 11.1** All documents relating to the Bid shall be in the English language.

12 Documents Comprising the Bid

- 12.1** The Bid submitted by the Bidder shall comprise the following:-
- (i) Bid Security in the form as specified in Clause 16 of these instructions.
 - (ii) Entire set of Bid Document issued by the department, duly filled & completed and signed on each page by the bidder in token of acceptance of all instructions and terms & conditions of the Bid Document.
 - (iii) All documents pursuant to Sub Cl. 4.2 of these instructions with supporting information and certificates required.
 - (iv) Any other material, information and certificate etc. required to be completed and submitted by the bidder in accordance with these instructions.

The Bid Security as per Sub Cl.12.1 (i) shall be submitted in separate sealed envelope bearing the name of work, name & address of the bidder and marked "BID SECURITY" on top. All other Bid Documents as per Sub Cl. 12.1 (ii), (iii) & (iv) shall be submitted in a separate sealed envelope bearing the name of work and name & address of the bidder.

12.2 The bidder shall prepare two copies (sets) of the Bid Documents. Each set comprising all the documents required as per Sub Cl. 12.1 (ii), (iii) & (iv) above shall be separately sealed and marked in accordance with the sealing and marking instructions given in Cl. 19 marking them "Original" and "Copy" respectively.

13 Bid Prices

13.1 The Contract shall be for the whole Works, as described in Sub Cl. 1. 1 based on the priced Bill of Quantities submitted by the Bidder.

13.2 The contractor shall quote / fill-in his offered item wise rates & prices and also the line total (both in figure and words.) for all items of works described in the Bill of Quantities (B.O.Q), along with the total bid price (both in figure and words). Items for which no rates or prices are entered by the bidder will not be paid-for by the employer when executed and shall be deemed to be covered by the other item rates and prices in the B.O.Q. Corrections, if any, shall be made by crossing out, rewriting and signing with date.

13.3 All duties, taxes, including customs and excise duty and other levies payable by the contractor under the contract, or for any other cause, shall be deemed to be included in the rates, prices and total bid-price submitted by the Bidder. In case, at the time of execution of works, exemption from a customs / excise duty is sought, it will be debited from the bid price submitted by the Bidder.

13.4 The rates and prices quoted by the Bidder shall be fixed for the entire duration of the contract and shall not be subject to revision, increase or adjustment on any account.

14 Currencies of Bid and Payment.

14.1 The unit rates and the prices shall be quoted by the bidder entirely in Indian Rupees. All payments shall be made in Indian Rupees.

15 Bid Validity

15.1 Bids shall remain valid for acceptance for a period not less than 3 (Three) calendar months after the deadline date for bid submission as specified in Cl. 20. A bid submitted with a shorter validity period shall be rejected as non-responsive. In case of discrepancy in bid validity period between that given by the undertaking (affidavit on ₹ 100.00 stamp paper) pursuant to Cl. 4.2 (f) and Form of Bid submitted by the bidder, the later shall be deemed to stand corrected in accordance with the former.

15.2 In exceptional circumstances, prior to expiry of the original time limit, the Employer may request that the bidders may extend the period of validity for a specified additional period. The request and the bidder's responses shall be made in writing or by cable / fax / e-mail. A bidder may refuse the request without getting his bid security forfeited. A bidder agreeing to the request will not be required or permitted to modify his bid rates & prices, but will be required to extend the validity of his bid security for a period of the extended validity, and in compliance with Cl. 16 in all respects.

16 Bid Security

16.1 The Bidder shall furnish the Bid Security in separate envelope marked as 'BID SECURITY' in accordance with details given in IFB.

16.2 Any bid not accompanied by an acceptable Bid Security and not submitted as indicated in Sub Cl. 16.1 above shall be rejected by the Employer as non-responsive.

16.3 The Bid Security of unsuccessful bidders will be returned within 45 days of the end of the Bid validity period specified in Sub Cl. 15.1.

16.4 The Bid Security of the successful Bidder will be discharged when the Bidder has signed the Agreement / Contract Bond and furnished the required Performance Security.

16.5 The Bid Security may be forfeited, if:-

- a) the Bidder withdraws or modifies the Bid after bid opening during the period of bid validity; or
- b) the Bidder does not accept the correction of the Bid Price, pursuant to Cl. 27; or
- c) in the case of a successful Bidder, he fails within the specified time limit to-
 - i. sign the Agreement / Contract Bond; or
 - ii. Furnish the required Performance Security.

17 Alternative Proposals by Bidders

17.1 Bidders shall submit offers that comply with the requirements of the bidding documents, including the conditions of contract, basic technical design as indicated in the drawings and specifications. Conditional offer or alternative offers will not be considered in the process of tender evaluation.

18 Format and Signing of Bid

18.1 The Bidder shall prepare one 'Original' and one 'Copy' of all the documents comprising the Bid as described in Cl. 12 of these Instructions to Bidders (ITB), bound with the volume containing the Bid in hard book binding (not spiral

binding) and clearly marked “ORIGINAL” & “COPY” as appropriate. In the event of discrepancy between them the original shall prevail.

- 18.2** All entries in the ‘Original’ and ‘Copy’ of the Bid shall be typed or written in indelible ink and shall be signed by a person or persons duly authorized to sign on behalf of the Bidder, pursuant to Sub Cl. 4.1, 4.2 and 4.3. All pages of the Bid and entries where amendments have been made shall be initialled by the persons signing the bid.
- 18.3** The Bid shall contain no alterations or additions, except those to comply with instructions issued by the Employer, or as necessary to correct errors made by the Bidder, in which case such corrections shall be initialled with date by the person or persons signing the Bid.

D. Submission of Bids

19 Sealing and Marking of Bids

- 19.1** (a) The Bidder shall seal the Bid in separate envelopes duly marked as “ORIGINAL” and “COPY”.
(b) The bidder shall seal all the envelopes, before submitting the bid as above.
- 19.2** The envelopes shall be addressed to Officer inviting the bids as mentioned in Bid Reference (Section-I) along with identification such as name of work, Bid No. & Name & Address of Bidder.
- 19.3** In addition to the identification required in Sub Cl. 19.2, each of the envelopes shall indicate the name and address of the bidder to enable the bid to be returned unopened in case it is declared late, pursuant to Cl. 21.
- 19.4** If an envelope is not sealed and marked as above, the Employer will assume no responsibility for the misplacement of any document or premature opening of the bid.

20 Deadline for Submission of Bids

- 20.1** Complete Bids must be received in the offices at the addresses specified in Bid Reference (Section-I). In the event of the specified date for the submission of bids is declared a holiday in the said offices, then the Bids will be received up to the specified time on the very next working day.
- 20.2** The Officer Inviting Bid may extend the deadline for submission of bids by issuing an amendment in accordance with Cl. 10, in which case all rights and obligations of the Officer Inviting Bid and the bidders previously subject to the original deadline will then be subject to the new deadline.

21 Late Bids

21.1 Any Bid received by the offices at the addresses specified in Bid Reference (Section-I), after the deadline prescribed in Cl. 20 will be returned unopened to the Bidder.

22 Modification and Withdrawal of Bids

22.1 Bidders may modify or withdraw their bids by giving notice in writing before the deadline prescribed in Cl. 20.

22.2 Each Bidder's modification or withdrawal notice shall be prepared, sealed, marked and delivered by him in accordance with Cl. 18 & 19, with envelopes additionally marked "MODIFICATION" or "WITHDRAWAL", as appropriate.

22.3 Neither the bid shall be modified by the Bidder nor entertained by the Tender Opening Authority after the deadline for submission of Bids.

22.4 Withdrawal or modification of a Bid between the deadline for submission of bids and the expiration of the original period of bid validity specified in Sub Cl. 15.1 above or as extended pursuant of Sub Cl. 15.2 may result in the forfeiture of the Bid Security pursuant to Cl. 16.

22.5 Bidders may offer discounts to, or otherwise modify the prices of, their Bids by submitting Bid modifications only in accordance with Sub Cl. 22.1 to 22.4 above, or may include such modifications in the original Bid submitted before deadline.

E. Bid Opening and Evaluation

23 Bid Opening

23.1 On the due date and appointed time & place, a committee comprising of one Superintending Engineer, two Executive Engineers and one Divisional Accountant will open Bid Envelope marked for all bids received (except those received late) including modifications made pursuant to Cl. 22 in the presence of the Bidders or their representatives who choose to attend at the time, date and place specified. If the specified date of Bid opening is declared a holiday in the concerned Superintending Engineer's Office, then the Bids will be opened at the specified time and location on the next working day.

23.2 Envelope marked "WITHDRAWAL" shall be opened and read out first. Bids for which an acceptable notice of withdrawal has been submitted pursuant to Cl. 22 shall not be opened. Subsequently, all envelopes marked 'MODIFICATION' shall be opened and the submission their-in shall be read out in appropriate detail.

23.3 The amount, form and validity of the Bid Security furnished with each bid will be announced. If the bid security furnished does not conform to the amount and validity period as specified in the Invitation for Bid (IFB) and has not been furnished compliant to Condition No. 3 of IFB (Section-II), the Bid shall be rejected and the bidder informed accordingly.

23.4 (i) Subject to confirmation of the Bid Security by the issuing Bank / Post Office, the bids accompanied with valid Bid Security shall be taken-up for evaluation. If any bid contains any deviation from the bid documents and / or deviation of the Bid Security, then the Bid will be rejected and the bidder will be informed accordingly.

(ii) The Employer shall prepare minutes of the Bid opening, including the information disclosed to those present, in accordance with Sub Cl. 23.3.

(iii) The Bid will be evaluated by Departmental Tender Committee on the basis of criteria as mentioned below:-

Attributes		Evaluation				Marks Obtained	
(A)	Financial strength-20 marks (i) Average annual turnover - 12 marks (ii) Solvency Certificate & Financial Capability-8 marks	(i) 60% marks for minimum eligibility criteria (ii) 100% marks for twice the minimum eligibility criteria or more In between (i) & (ii) – on pro-rate basis					
(B)	Experience in similar works - 20 marks	(i) 60% marks for minimum eligibility criteria (ii) 100% marks for twice the minimum eligibility criteria or more In between (i) & (ii) – on pro-rate basis					
(C)	Performance of works- 40 marks						
	Parameter	Criteria for points	Score			Maximum marks	
	1. <u>Timely Completion of Works</u> Assessed by Time Over Run (TOR) (a) Without levy of compensation (b) With levy of compensation (c) Levy of compensation not decided TOR=AT/ST, Where AT= Actual Time; ST= Stipulated Time	If TOR upto	1.00	2.00	3.00	> 3.00	25
			25	20	10	0	
			20	10	5	0	
			20	10	5	0	

Note: Marks for value in between the stages indicated above is to be determined by straight line variation basis.					
2. <u>Quality of Works</u>		(i) Very Good (ii) Good (iii) Fair/ Satisfactory (iv) Poor	15 10 5 0	15	
(D)	<u>Personnel and Establishment - 10 marks</u>	Key Personnel & Supervisory Staff per Cl.3.5 (l) above (details given in Contract Data, i.e. Section-VII)	(i) 80% for minimum Eligibility Criteria (ii) 100% for 1.5 times of minimum Eligibility Criteria In between (i) & (ii) – on pro-rate basis	Max. 10 marks	
(E)	<u>Plant & Equipment -10 marks</u>	Equipments & Machinery as per Cl.3.5 (k) above (details given in Contract Data, i.e. Section-VII)	(i) 80% for minimum Eligibility Criteria (ii) 100% for 1.5 times of minimum Eligibility Criteria In between (i) & (ii) – on pro-rate basis	Max. 10 marks	
	Total-100 Marks	Minimum Qualifying Marks	60 marks overall (Subject to minimum 60% qualifying marks in individual item also)	Max. Marks – 100	

(iv) The names of responsive bidders, whose bids after evaluation, are found to be in accordance with the requisite and prescribed qualifying criteria for eligibility, shall be displayed in the office of Employer / Engineer and also uploaded on departmental website.

24 Process to be Confidential

24.1 Information relating to the examination, clarification, evaluation, and comparison of bids and recommendations for the award of a contract shall not be disclosed to the bidders or any other persons not officially involved with such process until the award of the Bid to the successful Bidder has been announced. Any effort by a Bidder to influence (in any manner whatsoever) the process, right from bid submission to the final bid award decision, may result in the rejection of his Bid.

25 Clarification of Bids

25.1 To assist in the examination, evaluation and comparison etc. of the Bids, the Officer Inviting Tender may at his discretion ask any Bidder for clarification of his Bid, including break-up of any rates / unit rates. The request for clarification and the response shall be in writing or by fax or e-mail, but no change in the price or substance of the Bid shall be sought, offered, or permitted except as required to confirm the correction of arithmetic errors found by the Officer Inviting Tender in the evaluation of the Bids in accordance with Cl. 27.

25.2 Subject to Sub Cl. 25.1, no Bidder shall contact the Officer Inviting Tender or any of his authorities on any matter relating to the Bids from the time of bid opening to the time of award of contract. If the Bidder wishes to bring additional information to the notice of the Departmental Authorities, he should do so in writing.

26 Examination of Bids and Determination of Responsiveness

26.1 Prior to detailed evaluation of Bids, the Departmental Tender Committee will determine whether each Bid-

(a) meets the eligibility criteria defined in this Bid Document.

(b) has been properly signed by the bidder or authorized signatory holding Power of Attorney in his favour.

(c) is accompanied by the required securities and

(d) is substantially responsive to the requirements of the bidding documents.

26.2 A substantially responsive Bid is one which conforms to all the terms, conditions, and specifications of the Bidding documents without material deviation or reservation. A material deviations or reservation is one :-

(a) which affects in any substantial way the scope, quality or performance of the works;

(b) which limits in any substantial way the Employer's rights or the Bidder's obligations under the Contract; or

(c) whose rectification would affect unfairly the competitive position of other Bidders presenting substantially responsive Bids.

26.3 If a Bid is not substantially responsive, it will be rejected by the Departmental Tender Committee or higher authorities, and may not subsequently be made responsive by correction or withdrawal of the non conforming deviation or reservation.

27 Correction of Errors

27.1 Bids determined to be substantially responsive will be checked by the Departmental Tender Committee for any arithmetic errors. Errors will be corrected by the Departmental Tender Committee as follows:

- a) Where there is a discrepancy between the rates in figures and in words, the rate in words will govern; and
- b) Where there is a discrepancy between the unit rate and the line-item-total, resulting from multiplying the unit rate by the quantity, the unit rate as quoted will govern.

27.2 The amount stated in the Bid will be corrected and adjusted by the Departmental Tender Committee in accordance with the above procedure for the correction of errors and with the concurrence of the Bidder shall be considered as binding upon the bidder. If the Bidder does not accept the corrected amount, the Bid will be rejected, and the Bid security may be forfeited in accordance with Sub Cl. 16.5

28. Deleted

29 Financial Evaluation and Comparison of Bids

29.1 The Departmental Tender Committee will evaluate and compare only the bids determined to be substantially responsive in accordance with Cl. 26.

29.2 In evaluating the bids, the Departmental Tender Committee will determine for each Bid the evaluated Bid Price by adjusting the Bid price as follows:

- (a) Making any correction for errors pursuant to Cl. 27; and/ or
- (b) Making an appropriate adjustments for any other acceptable modifications, variations and deviations; and / or
- (c) Making appropriate adjustments to reflect discounts or other price modifications offered before the deadline for submission of the bid.

29.3 The Departmental Tender Committee reserves the right to accept or reject any variation or deviation. Variations and deviations and other factors, which are beyond the provisions, requirements and scope of the Bidding documents, shall not be taken into account in Bid evaluation.

29.4 If the Bid of the successful Bidder is seriously unbalanced in relation to the Employer's estimate of the cost of work to be performed under the contract, the Employer may require the Bidder to produce detailed price analysis for any or all items of the Bill of Quantities, to demonstrate the internal consistency of those prices with the implementation / construction methods and schedule proposed. After evaluation of the price analysis, the employer may require that the amount of the performance security set forth in Cl. 34 be increased at the expense of the successful bidder to a level sufficient to protect the Employer against financial loss in the event of default of the successful bidder under the contract.

29.5 A bid which contains several items in the Bill of Quantities which are unrealistically priced low and which cannot be substantiated satisfactorily by the bidder may be rejected as non responsive.

29.6 Conditional Bids are liable to be rejected.

30. Negotiation with Bidders

Negotiation with Bidders after bid opening shall not normally be done. However, in exceptional circumstances where price negotiations is considered necessary due to some unavoidable circumstances, the same may be resorted to only with the lowest evaluated responsive bidder.

F. Award of Contract

31 Award Criteria

31.1 The designated competent authority of the department will ordinarily award the Contract on recommendation of the Departmental Tender Committee to the Bidder whose Bid has been determined to be substantially responsive to the Bidding documents and who has offered the lowest evaluated Bid Price, provided that such Bidder has been determined to be (a) eligible in accordance with the provisions of Cl. 3 and (b) qualified in accordance with the provisions of Cl. 4.

32 Employer's Right to accept any Bid and to reject any or all Bids

32.1 Notwithstanding Cl. 31, the Employer reserves the right to accept or reject any Bid, and to cancel the bidding process and reject all bids, at any time prior to the award of Contract, without thereby incurring any liability to the affected Bidder or bidders or any obligation to inform the affected Bidder or bidders of the grounds for the Employer's action.

33 Notification of Award and Signing of Agreement

33.1 The bidder whose Bid has been accepted will be notified of the award by the Employer prior to expiration of the Bid validity period by cable, telex or facsimile confirmed by registered letter. This letter (hereinafter and in the *Conditions of Contract* called the "Letter of Acceptance") will state the sum that the Employer will pay to the Contractor in consideration of the execution, completion and maintenance of the Works by the Contractor as prescribed by the Contract (hereinafter and in the Contract called the "Contract Price").

33.2 The notification of award will constitute the formation of the Contract, subject only to the furnishing of a performance security in accordance with the provisions of Cl. 34.

33.3 The Agreement will incorporate all correspondence between the Employer and the successful Bidder. It will be signed by the Employer and kept ready for signatures of the successful Bidder in the office of employer within 28 days following the notification of award along with the letter of Acceptance. Within 21 days of receipt of this letter, the successful Bidder will furnish performance security, stamp papers of requisite amount as per the current Stamp Act and sign the Agreement with the Employer.

33.4 Upon the furnishing by the successful Bidder of the Performance Security, the Employer will promptly notify the other Bidders that their Bids have been unsuccessful and accordingly release their Bid security.

34. Performance Security

34.1 Within 21 days of receipt of the Letter of Acceptance, the successful Bidder shall deliver to the Employer a Performance Security in any of forms given below for an amount equivalent to 5% of contract price plus additional security for unbalanced bids in accordance with Cl. 29.4 of ITB and Cl. 52 of GCC:-

- (a) Fixed Deposit Receipt from any Public Sector (SBI & Nationalized) / Scheduled Bank located in India.
- (b) National Savings Certificate issued by any Indian Post Office duly endorsed by the competent postal authority in India.

34.2 Failure of the successful bidder to comply with the requirements of Sub Cl. 34.1 shall constitute a breach of contract, cause for annulment of the award, forfeiture of the bid security and any such other action, the Employer may deem fit under the contract and the Employer may resort to awarding the contract to the next ranked responsive bidder.

35 Settlement of Disputes

35.1 Disputes between Contractor and Engineer / Employer shall be resolved as per the provisions of Cl. 24 & 25 of General Condition of Contract (Section IV).

36 Corrupt or Fraudulent Practices

36.1 The Employer requires the Bidders / Suppliers / Contractors under this contract to observe the highest standard of ethics during the procurement and execution of this contract. In pursuance of this policy:-

- (i) "Corrupt practice" means the offering, giving, receiving or soliciting of anything of value or significance to influence the action of a public official in the procurement process or in Contract execution, and
- (ii) "Fraudulent Practice" means a misrepresentation of facts in order to influence a procurement process or the execution of a contract to the detriment of the Employer and includes collusive practices among Bidders (prior to or after bid submission) designed to establish bid prices at artificial non-competitive levels and to deprive the Employer of the benefits of free and open competition.

- 36.2** The employer will reject a proposal for award of work if he determines that the Bidder recommended for award has been engaged in corrupt or fraudulent practices in competing for the contract in question and will declare a Bidder ineligible either indefinitely or for a stated period of time, to be awarded a contract / contracts if he, at any time determines that the bidder has been engaged in corrupt or fraudulent practices in competing for, or in executing the contract.
- 36.3** After the award of work & signing the Contract Bond, sub-letting any work or part thereof to any other contractor, except as submitted with the bid documents under Sub Cl.4.2 (r), by the Bidder / Lead Partner of a JV is strictly prohibited. If at any stage, it is found that the contractor has indulged in subletting the work or part thereof to any other contractor in contravention of the above, it shall be considered a serious violation of the conditions of the Contract and this act shall also be treated as corrupt & fraudulent practice and in that case the contract bond is likely to be rescind with forfeiture of the full Performance Security deposit.

SECTION - IV

GENERAL

CONDITIONS

OF

CONTRACT

(G.C.C.)

General Conditions of Contract

Table of Contents

		Page No.			Page No.
A.	General		C.	Quality Control	
1	Definitions	35	32	Identifying Defect	48
2	Interpretation	37	33	Tests	48
			34	Completion and commissioning of work	50
3	Language and Law	38	35	Correction of Defects	50
4	Engineer's Decisions	38	36	Uncorrected of Defects	51
5	Delegation	38			
6	Communications	38	D.	Cost Control	
7	Subcontracting	38	37	Bill of Quantities	51
8	Other Contractors	38	38	Changes in the Quantities	51
9	Personnel	38	39	Variations	51
10	Employer's & Contractor's Risks	39	40	Payments for Variations	51
11	Employer's Risks	39	41	Cash Flow Forecasts	52
12	Contractor's Risks	39	42	Payment Certificates	52
13	Insurance	40	43	Payments	52
14	Site Investigation Reports	40	44	Compensation Events	54
15	Queries about the Contract Data	40	45	Tax	54
					54
16	Contractor to Construct the Works	40	46	Currencies	
			47	Appreciation	54
17	The Works to Be Completed by the Intended Completion Date	41	48	Retention	54
			49	Liquidated Damages	55
18	Approval by the Engineer	41	50	Penalty	55
19	Safety	42	51	Advance Payment	55
20	Discoveries	42	52	Securities	56
21	Possession of the Site	42	53	Cost of Repairs	56
22	Access to the Site	42			
23	Instructions	42	E.	Finishing the Contract	
24	Disputes	43	54	Completion	56
25	Procedure for Disputes	43	55	Taking Over	56
26	Replacement of Adjudicator	46	56	Final Account	56
			57	Drawings / Manuals	57
B.	Time Control		58	Termination	57
27	Program	46	59	Payment upon Termination	59
28	Extension of the Intended Completion Date	47	60	Property	59
			61	Release from Performance	59
29	Delays Ordered by the Engineer	47	62	Fraud & Corruption	59
30	Management Meetings	47	F.	Special Conditions of Contract	
31	Early Warning	48			60

A. General

1. Definitions

- 1.1** Terms which are defined in the Contract Data (Section-VII) other than those defined hereunder shall keep their respective meanings as defined therein. Capital initials are used to identify the defined terms.

The **Adjudicator** (synonymous with the Dispute Review Expert) is the person appointed jointly by the Employer and the Contractor to resolve disputes in the first instance, as provided for in Cl. 24 and 25 hereunder.

Bill of Quantities means the priced and completed Bill of Quantities forming part of the Bid.

Chief Engineer means the Zonal Chief Engineer of that Zone under which the work / Divisional Office lies.

Compensation Events are those defined in Cl. 44 hereunder.

The **Completion Date** is the actual date of completion of the Works as certified by the Engineer in accordance with Sub Cl. 54.1.

The **Contract** is the agreement in the form of a Contract Bond between the Employer and the Contractor to execute & complete the works in a specified time and thereafter to maintain them during the defect liability period specified therein. It consists of the documents listed in Sub Cl. 2.3 below.

The **Contract Data** defines the documents and other information which comprise the Contract.

The **Contractor** is a person or a corporate body (which may be a Firm, a Company or a Joint Venture) whose bid has been accepted by the Employer to carry out the Works.

The **Contractor's Bid** is the duly completed Bidding Document submitted by the Contractor to the Employer.

The **Contract Price** is the price stated in the Letter of Acceptance and thereafter as adjusted in accordance with the provisions of the Contract.

Days are calendar days; **months** are calendar months and **years** are calendar years.

A **Defect** is any part of the Works not completed in accordance with the Contract.

The **Defects Liability Period** is the period specified in the Contract Data and calculated from the Completion Date.

The **Employer** is the authority named in the Contract Data who will employ the Contractor to carry out the Works by means of Contract Bond.

The **Engineer** is the person named in the Contract Data (or any other competent authority working under him, authorized and notified to the contractor, to act in replacement of the Engineer) who is responsible for supervising the execution of the works and administering the Contract.

The **Engineer's Representatives** are the persons named in the Contract Data who are responsible for supervising the execution of the works on behalf of the Engineer.

Equipment is the Contractor's machinery (including Tools & Plants) and vehicles brought temporarily to the site for proper execution of works.

The **Initial Contract Price** is the Contract Price listed in the Employer's Letter of Acceptance.

The **Intended Completion Date** is the date on which it is intended that the Contractor shall complete the works. The Intended Completion Date is specified in the Contract Data. The Intended Completion Date may be revised/ extended only by the competent authority by issuing an extension of time.

Materials are all supplies, including consumables, intended to be used and brought to site / site store, including their quantity actually consumed, by the Contractor in the Works.

Managing Director is the authority in which the powers of Head of Department (HOD) of Uttarakhand Peyjal Nigam are vested.

Owner is Uttarakhand Peyjal Sansadhan Vikas Evam Nirman Nigam (Uttarakhand Peyjal Nigam) through its Chairman.

Plant is any integral part of the Works which is to have a mechanical, electrical, electronic or chemical or biological function.

The **Site** is the project area as defined in the Contract Data.

Site Investigation Reports are those which are either included in the Bidding documents, or required to be submitted by the Contractor therein after conducting the specified site investigations, and are factual interpretative reports about the surface and sub-surface conditions at the site.

Specifications mean the Specifications of the Works included in the Contract and any modifications or additions made / approved by the Employer for proper execution and completion of works.

The **Start Date** is given in the Contract Data. It is the date when the Contractor is required to commence the execution of contracted works. It does not necessarily coincide with any of the Site Possession Dates.

A **Subcontractor** is a person or corporate body (which may be a Firm or a Company) who has a Sub-Contract with the Contractor, in conformity of provisions contained in Cl. 7 below, to carry out a part of the work in the Contract which includes work on the Site.

Temporary Works are the works which are designed, constructed and installed by the Contractor, needed for proper construction or execution of the Works and are to be removed or removed thereafter.

A **Variation** is the difference in quantities of works resultant to any instructions duly given by the Engineer / Employer / Higher Authorities either in writing or verbally which varies the Works. Any such verbal instructions shall immediately be confirmed by the contractor in writing to the Employer duly acknowledged by his office.

The **Works** are all that which the Contract requires the Contractor to construct, install, maintain during the defect liability period and handover to the designated authority, as defined in the Contract Data.

2. Interpretation

- 2.1** In interpreting these General Conditions of Contract, singular also means plural, male also means female or neuter, and the other way around. Headings have no significance. Words have their normal meaning under the language of the Contract unless specifically defined. The Engineer / Employer will provide instructions clarifying queries about the Conditions of Contract.
- 2.2** If sectional completion is specified in the Contract Data, references in the Conditions of Contract to the Works, the Completion Date, and the Intended Completion Date apply to any Section of the Works (other than references to the Completion Date and Intended Completion date for the whole of the Works).
- 2.3** The documents forming the Contract shall be in the following order:
- (1) Agreement
 - (2) Copies of Performance Security Documents
 - (3) Letter of Acceptance
 - (4) Section VII of Contractor's Bid (Contract Data)
 - (5) Section X of Contractor's Bid (Form of Bid)
 - (6) Section XI of Contractor's Bid (Bill of Quantities)

- (7) Section IV of Contractor's Bid (General Conditions of Contract including Special Conditions of Contract)
- (8) Section V of Contractor's Bid (Specifications)
- (9) Section VI of Contractor's Bid (Drawings)
- (10) Remaining Sections I, II, III, VIII & IX of Contractor's Bid
- (11) Supporting documents of Section VIII & IX of Contractor's Bid
- (12) Any other document required for forming the Contract.

3. Language and Law

- 3.1** The language of the Contract and the law governing the Contract are stated in the Contract Data and Section-F of this GCC (Special Conditions of Contract).

4. Engineer's Decisions

- 4.1** Except where otherwise specifically stated, the Engineer, in the role representing the Employer, will decide all routine contractual matters between the Employer and the Contractor.

5. Delegation

- 5.1** The Engineer may delegate any of his duties and responsibilities to any of his representatives after notifying the Contractor and may cancel any such delegation after notifying the Contractor. Similarly, the Employer may also delegate any of his duties and responsibilities to the Engineer or his representative in the like manner.

6. Communications

- 6.1** Communications between parties which are referred to in the conditions shall be effective only when made in writing or by e-mail at Contractor's ID. A notice shall be effective only when it is delivered or deemed to be delivered as per law / in terms of Indian Contract Act.

7. Subcontracting

- 7.1** Normally, Subcontracting of works is not allowed in case of Joint Venture. However, the contractor can employ sub-contractors only for specialized works details of which shall be given by the bidder, at the time of bidding, in the Form-XIV as per Cl.4.2 (r) of ITB (Section-III). Subcontracting does not alter the Contractor's obligations in any manner.

8. Other Contractors

- 8.1** The Contractor shall cooperate and share the Site with other contractors, the Employer / Engineer / their representatives, public authorities, utility services etc, as required according to their schedule of various activities during the currency of the Contract including defect liability period. The Contractor

shall also provide all necessary facilities and services for them. The Employer / Engineer may modify the schedule of other contractors and shall notify the contractor of any such modification.

9. Personnel

- 9.1** The Contractor shall employ the key personnel named in the Schedule of Key Personnel as referred to in the Contract Data to carry out their functions for proper execution and completion of works stated in the Schedule. The Employer / Engineer may ask the Contractor for replacement of any key personnel listed in the Schedule with the personnel having equivalent or better qualifications, abilities, and relevant work experience and will, accordingly, approve the revised list of key personnel.
- 9.2** If the Engineer / Employer / any Higher Authority ask the Contractor to remove a person who is a member of the Contractor's staff or his work-force stating the reasons, the Contractor shall ensure that the person leaves the Site within three days and has no further connection with the work in the Contract. If any such person is declared undesirable, then he will have to leave the site immediately.

10. Employer's and Contractor's Risks

- 10.1** The Employer carries the risks which this Contract states are Employer's risks, and the Contractor carries the risks which this Contract states are Contractor's risks.

11. Employer's Risks

- 11.1** The Employer is responsible for the excepted risks which are-(a) the risks of war, hostilities, invasion, act of foreign enemies, rebellion, revolution, insurgency, military coup or usurp of power, civil war, riot, commotion or disorder (if not restricted to the Contractor's employees), and contamination from any nuclear fuel or nuclear waste or radioactive toxic explosive and any such other happening in the Employer's country, in so far as they directly affect the execution of the Works, or (b) a cause due, solely, to the design of the Works, other than the Contractor's design, or (c) dispute by villagers on land / source / pipeline alignment etc., or (d) delay in forest land acquisition, or (e) non availability of funds, or (e) delay due to natural calamities like landslide, flood, earthquake, cloud burst etc.

12. Contractor's Risks

- 12.1** All risks of loss of, or damage to, physical property (either pertaining to the Contracted Works or to the Employer or any Third Party) and of personal injury and death (of Contractor's staff / member of work-force or the Employer's staff or any Third Party) which arise during and in consequence of the performance of the Contract, other than the excepted risks, are the responsibility of the Contractor.

13. Insurance

13.1 The Contractor, at his own cost shall provide, in the joint names of the Employer and the Contractor, insurance cover from the Start Date to the end of the Defects Liability Period, in the amounts and deductibles stated in the Contract Data for the following events which are due to the Employer's risks and Contractor's risks as well:

- (a) loss of or damage to the Works, Plant and Materials;
- (b) loss of or damage to Equipment;
- (c) loss of or damage of property (except the Works, Plant, Materials and Equipment) in connection with the Contract; and
- (d) personal injury or death.

13.2 Policies and certificates for insurance shall be delivered by the Contractor to the Employer for his approval before the Start Date. All such insurance shall provide for compensation to be payable in the types and proportions of currencies required to completely rectify / compensate the loss or damage incurred.

13.3 If the Contractor does not provide the required insurance policies and certificates within stipulated time, then the Employer may affect the insurance which the Contractor should have provided and recover the premium which the Employer has paid from payments otherwise due to the Contractor or, if no payment is due, the payment of the premium shall be a debt due.

13.4 Both parties, the Contractor and the Employer, shall comply with all conditions of the insurance policies.

13.5 However, any alterations to the terms of insurance shall not be made, either by the Contractor or by the Insurance Company, without prior approval of the Employer.

14. Site Investigation Reports

14.1 The Contractor, in preparing the Bid, shall rely on any site Investigation Reports referred to in the Contract Data, supplemented by any other information available to the Bidder.

15. Queries about the Contract Data

15.1 The Engineer / Employer will clarify queries on the Contract Data.

16. Contractor to Construct the Works

16.1 The Contractor shall make necessary arrangements, at his own cost, for detailed survey to verify the actual availability and levels of suitable site locations for different components of works as well as alignments of pipeline, and shall intimate his findings to the Engineer in writing. If any significant change from the sanctioned project proposal is found, then the Contractor shall get the designs and drawings modified accordingly, at his own cost, in compliance of Engineer's / Employer's written directions for the same and shall get such modified designs and drawing approved by competent technical authority, through the Engineer, before procurement of material for works and actually starting the execution of works. The contractor shall construct and install all the Works in accordance with the approved Specifications of works and as per the approved Designs and Drawings, and also ensuring the compliance of the Engineer's / his Representatives' / Employer's / Higher Authority's instructions. The Contractor shall be solely responsible for proper workmanship, timely completion and due performance of all the works.

16.2 Protection of Environment:

The contractor shall take all reasonable steps to protect the environment on and off the Site and to avoid damage or nuisance to persons or to property of the public or others resulting from pollution, noise or other undesirable causes arising as a consequence of his methods of operation. During continuance of the contract, the contractor and his sub-contractors shall abide at all times by all existing enactments on environmental protection and rules made there under, regulations, notifications and bye-laws of the State or Central Government, or local authorities and any other law, bye-law, regulations that may be passed or notification that may be issued in this respect in future by the State or Central Government or the local authority.

17. The Works to Be Completed by the Intended Completion Date

17.1 The Contractor shall make all efforts to commence the execution of the Works on the Start Date and shall carry out the Works in accordance with the program submitted by the Contractor and duly approved by the Engineer / Employer and modified / updated by Competent Authority, if necessary. This program shall invariably be within the framework of the mile-stones prescribed in Contract Data (Section-VII), in order that all the works are completed in all respect by the Intended Completion Date.

18. Approval by the Engineer

18.1 The Contractor shall submit, and get approved by the Engineer, all the Specifications, Designs, Drawings & Site Plan showing locations of all the proposed Temporary Works, required to execute the Contract.

18.2 The Contractor shall solely be responsible for safe design of Temporary Works and safety of all materials / machinery / equipments etc. stored / placed in them and all residing / handling personnel.

18.3 The Engineer's approval shall not relieve the Contractor of his responsibility of proper design and safety of the Temporary Works.

18.4 The Contractor shall obtain approval of third parties deployed by the owner / Govt. on the design and layout of the Temporary Works where required.

19. Safety

19.1 The Contractor shall be responsible for the safety of all activities on the Site.

20. Discoveries

20.1 Anything of historical or other interest or of significant value, discovered on the Site, shall be the property of the Employer. The Contractor is to notify the Engineer of such discoveries and strictly carry out the Engineer's instructions for dealing with them.

21. Possession of the Site

21.1 The Employer shall give possession of all parts of the Site to the Contractor. If possession of any part is not given by the date stated in the Contract Data, the Employer is deemed to have delayed the start of the relevant activities and this will be a Compensation Event.

22. Access to the Site

22.1 The Contractor shall allow the Engineer / Employer / Higher Authorities, and any person authorized by them, access to the Site or to any place where work in connection with the Contract is being carried out or is intended to be carried out and to any place where materials or plant are being installed / manufactured / fabricated / assembled / stored for the works.

23. Instructions

23.1 The Contractor shall carry out all instructions of the Engineer / Employer / Higher Authorities / their Authorized Representatives which comply with the provisions of the Contract as well as with the laws / bye-laws applicable to the area where the Site is located.

23.2 The Contractor shall permit the Engineer / Employer to inspect the Contractor's accounts and records relating to the performance of the Contractor and to have them audited by auditors appointed by the Employer, if so required by the Employer.

24. Disputes

24.1 If the Contractor believes that a decision taken by the Engineer / Employer was either outside the authority given to the Engineer / Employer by the Contract / relevant law / delegated by the Owner or the decision was wrongly taken, the matter shall be referred to the Employer / 1st Appellant Authority within 14 days of the notification of the Engineer's / Employer's decision. If the contractor is still not satisfied with the decision of Employer / 1st Appellant Authority, the settlement of dispute will further be taken as follows-

S. No.	Contract value	1 st Appellant Authority	2 nd Appellant Authority	3 rd Appellant Authority
1	Upto ₹ 10 Lakhs	Executive Engineer	Superintending Engineer	Sole Arbitrator
2	₹ 10 Lakhs to ₹ 75 Lakhs	Superintending Engineer	Superintending Engineer (Other Circle)	Sole Arbitrator
3	₹ 75 Lakhs to ₹ 5 Crore	Chief Engineer (Zonal)	Chief Engineer (Other Zone)	Sole Arbitrator
4	₹ 5 Crore to ₹ 25 Crore	Chief Engineer (Zonal)	Managing Director	Sole Arbitrator
5	More than ₹ 25 Crore	Managing Director	Adjudicator	Panel of Arbitrators

Note:

- 1-Adjudicator for S.No.5 shall not be below the rank of Chief Engineer (Level-1)*.
- 2-Arbitrator for S.No.1 & 2 shall not be below the rank of Superintending Engineer*.
- 3-Arbitrator for S.No.3 shall not be below the rank of Chief Engineer (Level-II)*.
- 4-Arbitrator for S.No.4 shall not be below the rank of Chief Engineer (Level-I)*.
- 5-Arbitrators in the Panel of Arbitrators for S.No.5 shall not be below the rank of Chief Engineer (Level-I)*.

* In service or retired from any Central Govt. / State Govt. / Central or State Govt. undertaking department of any state in India.

25. Procedure for Settlement of Disputes

25.1 The 1st / 2nd Appellant Authority shall give a decision in writing within 60 days of receipt of notification of a dispute. Either party of the Contract may refer a decision of the 1st Appellant Authority to the 2nd Appellant Authority or the decision of 2nd Appellant Authority to an Arbitrator / Panel of Arbitrators (3rd Appellant Authority) within 28 days of the 1st / 2nd Appellant Authority's written decision, as the case may be. If neither party refers the dispute to 2nd / 3rd Appellant Authority within the above 28 days, then in that case, the 1st / 2nd Appellant Authority's decision will be final and binding.

25.2 The Adjudicator shall be paid a gross Settlement Fees as agreed between the Adjudicator and the parties of the Contract subject to ceiling, if any, specified by Uttarakhand Government. In addition to this, daily fees for hearing at his place or at the court of jurisdiction of concerned district headquarter shall be paid at the rate as agreed together with other reimbursable expenses of the types specified therein. All such gross & daily fees, together with other expenses, shall be divided equally between the Employer and the Contractor, whatever decision is reached by the Adjudicator. Either party may refer a decision of the Adjudicator for Arbitration within 28 days of the Adjudicator's written decision. If neither party refers the decision of Adjudicator for arbitration within the above 28 days, the Adjudicator's decision will be final and binding.

25.3 The arbitration shall be conducted as per following procedure:-

(a) For the contracts of value Rs. 25 Crore & below –

The decision of 2nd Appellant Authority on disputes or differences shall be referred to a Sole Arbitrator. The Sole Arbitrator shall be appointed by agreement between the parties of the Contract; failing such agreement, the Arbitrator shall be appointed by the appointing authority, namely President of the Local Chapter of Institution of Engineers (India), falling within the State of Uttarakhand. The Arbitration shall be conducted and settled in accordance with the Indian Arbitration and Conciliation Act, 1996. The Arbitrator shall be paid a gross Settlement Fees as agreed between the Arbitrator and the parties of the Contract subject to ceiling, if any, specified by Uttarakhand Government. In addition to this, daily fees for hearing at his place or at the court of jurisdiction of concerned district headquarter shall be paid at the rate as agreed together with other reimbursable expenses of the types specified therein. All such gross & daily fees, together with other expenses, shall be divided equally between the Employer and the Contractor, whatever decision is reached by the Arbitrator.

(b) For the contracts of value more than Rs.25 Crore –

i. The decision of 2nd Appellant Authority on disputes or differences shall be referred to a Panel of Arbitrators. In case of a domestic Contractor, arbitration on such disputes or differences shall be settled in accordance with the Indian Arbitration and Conciliation Act, 1996. The Arbitral Tribunal (Panel of Arbitrators) shall consist of three Arbitrators, one each to be appointed by the Employer & the Contractor and the third Arbitrator shall be chosen by the two Arbitrators so appointed by the Parties and shall act as Presiding Arbitrator. In case of failure of the two arbitrators appointed by the parties of the Contract to reach upon a consensus regarding the choice of the third Arbitrator, within a period of 30 days after their appointment, then the third Arbitrator shall be appointed subsequently by President of the Local Chapter of Institution of Engineers (India), falling within the State of Uttarakhand.

- ii. In case of a foreign Contractor, arbitration on such disputes & differences shall be conducted and settled in accordance with provisions of the Indian Arbitration and Conciliation Act, 1996, if the Contractor consents so. However, if he doesn't, then it may be conducted and settled in accordance with the UNCITRAL Arbitration Rules. The Arbitral Tribunal (Panel of Arbitrators) shall consist of three Arbitrators, one each to be appointed by the Employer and the Contractor. The third Arbitrator shall be chosen by the two Arbitrators so appointed by the Parties of the Contract and shall act as the Presiding Arbitrator. In case of failure of the two arbitrators appointed by the parties of the Contract to reach upon a consensus regarding the choice of the third Arbitrator, within a period of 30 days after their appointment, then the third Arbitrator shall be appointed subsequently by President of the Local Chapter of Institution of Engineers (India), falling within the State of Uttarakhand.
- iii. If one of the parties fails to appoint its arbitrator in pursuance of sub-clause (a) and (b) (i) & (b) (ii) above within 30 days after receipt of the notice of the appointment of its arbitrator by the other party, then the President of Local Chapter of the Institution of Engineers (India) falling within the State of Uttarakhand, both in cases of the Indian Contractor as well as Foreign Contractor, shall appoint the arbitrator. A certified copy of the order of President of the Local Chapter of Institution of Engineers (India), making such an appointment shall be furnished to each of the parties.
- iv. Arbitration proceedings shall be held only at court of jurisdiction of respective district headquarter and the language of the arbitration proceedings and that of all documents and communications between the parties shall be either in Hindi or in English, in case of Indian Contractor and in English, in case of Foreign Contractor.
- v. The decision of the majority of arbitrators shall be final and binding upon both the parties of the Contract.
- vi. The expenses incurred by each party in connection with the arbitration proceedings as also the fees and expenses payable to the Arbitrator appointed by such party or on its behalf shall be borne by each party itself. The Arbitrator, appointed by the Employer / Owner, shall be paid a gross Settlement Fees as agreed between the Arbitrator and the Employer subject to ceiling, if any, specified by Uttarakhand Government. In addition to this, the Arbitrator appointed by the Employer / Owner shall be paid daily fees for hearing at his place or at the court of jurisdiction of concerned district headquarter shall be paid at the rate specified in the Contract Data together with other reimbursable expenses of the types specified therein. The third Arbitrator, who heads the Panel of Arbitrators, shall be paid gross Settlement Fees slightly higher (maximum upto 20%) than the fees of the Arbitrator appointed by the Employer / Owner, subject to ceiling, if any, specified by Uttarakhand Government. In addition, he will be paid daily fees for hearing and other reimbursable expenses at the same rate as applicable to the Arbitrator appointed by Employer / Owner. All such gross & daily fees, together with other expenses payable to the third

Arbitrator, shall be divided equally between the Employer and the Contractor, whatever decision is reached by the Panel of Arbitrators.

- vii. Performance under the contract shall continue during the arbitration proceedings and payments due to the contractor by the Engineer / Employer / Owner shall not be withheld, unless they are the subject matter of the arbitration proceedings.

26. Replacement of Adjudicator / Arbitrator

- 26.1** Should the Adjudicator or any Arbitrator resign or die during the process of Adjudication / Arbitration, or should the Employer and the Contractor agree that the Adjudicator / Arbitrator is not fulfilling his functions in accordance with the provisions of the Contract and / or the relevant Arbitration Act / Rule, they shall jointly sign a declaration to discontinue the appointment of such Adjudicator / Arbitrator; and a new Adjudicator / Arbitrator shall be jointly appointed by the Employer and the Contractor. In case of disagreement in this regard between the Employer and the Contractor, within 30 days, the Adjudicator / Arbitrator shall be appointed by the Appointing Authority specified in the Contract Data at the request of either party. The gross Settlement Fees, or any part thereof, shall not be payable to such resigned / deceased / discontinued Adjudicator / Arbitrator.

B. Time Control

27. Program

- 27.1** Within the time stated in the Contract Data and the milestones specified therein, the Contractor shall submit to the Engineer / Employer for approval a Program for execution of the Works including Environmental Management Plan showing the general methods, arrangements, sequence and timing for all the activities necessary for the Works along with monthly cash flow forecast. This Program shall necessarily include PERT Chart as well as Bar Chart of all the activities.
- 27.2** An update of the Program shall be a program showing the actual progress achieved on each activity and the effect of the progress achieved on the timing of the remaining works including any changes to the sequence of the activities required for timely completion of works within the Intended Completion Period.
- 27.3** The Contractor shall submit to the Engineer / Employer, for approval, an updated Program at intervals no longer than the period stated in the Contract Data. If the Contractor does not submit an updated Program within this period, the Engineer / Employer may withhold the amount stated in the Contract Data from the next payment certificate and continue to withhold this amount until the next payment up to the date on which the overdue Program has been submitted.

27.4 The Engineer's / Employer's approval of the Program shall not alter the Contractor's obligations of timely completion of works within the Intended Completion Period. The Contractor may revise the Program and submit it to the Engineer / Employer again at any time. A revised Program is to show the effect of Variations and Compensation Events also.

28. Extension of the Intended Completion Date

28.1 The Engineer / Employer / Higher Competent Authority may extend the Intended Completion Date, if a Compensation Event occurs or a Variation is necessitated which makes it impossible for Completion to be achieved by the Intended Completion Date without taking additional steps to accelerate the remaining work and which would cause the Contractor to incur additional costs.

28.2 The Engineer / Employer / Higher Competent Authority shall decide whether to extend and by how much to extend the Intended Completion Date, within 30 days of the Contractor asking the Engineer for a decision, upon the effect of a Compensation Event or Variation by submitting full supporting information. If the Contractor fails to give early warning of a possible delay in writing to the Engineer or fails to notify the Engineer about the hindrances causing unavoidable and justifiable delay, which is beyond his control, within a week of commencement of such delay / hindrance or fails to deal with the hindrances responsible for any avoidable delays, such delays shall not be considered in assessing the new Intended Completion Date. Employer's decision regarding the Contractor's failure to deal with avoidable delays due to any reason shall be final and binding. The delay in procurement of material for whatsoever reason, except due to natural calamities, shall also not be considered for extension of Intended Completion Date.

29. Delays Ordered by the Engineer / Employer

29.1 The Engineer / Employer may instruct the Contractor to delay the start or progress of any activity within the Works, at any time during the currency of the Contract, if he considers it proper in the interest of works or for safety of works / staff / material / third party. The Contractor shall not be entitled to any compensation for such delays, but the Engineer / Employer / Higher Authorities may consider the same for extension of Intended Completion Date.

30. Management Meetings

30.1 Either the Engineer or the Employer may require the Contractor to attend a Management Meeting at any time during progress of work. The objective of a Management Meeting shall be to review the plans for the remaining works and to deal with matters raised in accordance with the early warning procedure.

30.2 The Engineer shall record the minutes of Management Meetings and shall provide copies of the same to all those attending the meeting and to the Employer as well. The responsibility of the parties for actions to be taken is to be decided by the Engineer / Employer either during the Management Meeting or after the Management Meeting and shall inform about it in writing to all concerned.

31. Early Warning

31.1 It shall be the duty of the Contractor to give an early warning, in writing, to the Engineer at the earliest regarding specific likely future events or circumstances that may adversely affect the progress of work or quality of the work or delay the execution of works or likely to increase the Contract Price.

31.2 The Contractor shall cooperate with the Engineer in considering any proposals and in carrying out, by anyone involved in the work, any resulting instructions of the Engineer to minimize or avoid the effect of any such events or circumstances on the works.

C. Quality Control

32. Identifying Defects & Shortcomings

32.1 The Engineer / Employer / Higher Authorities shall check the Contractor's work, but such checking shall not relieve the Contractor of his responsibilities regarding correctness, quality and quantity of works in any manner. The Engineer / Employer / Higher Authorities shall notify the Contractor of any defects or shortcomings that are found and instruct the Contractor to search for a defect or shortcoming and to uncover and test any work which may have a defect or shortcoming in their opinion.

32.2 The contractor shall permit the Engineer's / Employer's / Owner's authorized representative or any Technical Auditor / Third Party designated by Owner / State / Central Govt. to check the contractor's work and to notify the Contractor of any defects or shortcomings that are noticed during inspections. Such a check shall neither relieve the Contractor's responsibilities regarding specifications as defined in the Contract Agreement nor shall relieve him from any responsibilities regarding proper performance of works.

33. Tests

33.1 All the civil construction and pipeline materials & fittings supplied (other than the materials provided by Uttarakhand Peyjal Nigam, if any) shall be got tested, prior to installation, through IIT, Roorkee / Sri Ram Institute of Industrial Research, Delhi or any other Institution of repute designated by the Engineer / Employer, by the contractor at his own expense. If the test report doesn't conform to relevant Specifications / IS Standards, the contractor will replace such defected materials from site within a week of receipt of the

report, at his own cost. The materials or fittings required to be tested prior to installation shall not be installed until the Engineer has approved the test results. The number of samples to be tested will be decided as per the directions of Engineer. All the samples shall be drawn and sealed jointly by the Contractor / his Authorized Representative and the Engineer / his Authorized Representative.

- 33.1*** The contractor will arrange for the testing of pumps, transformers at manufacturer works as per Schedule-E / Technical Specifications. Department will depute its representative to witness the test and the final test of pump and other material shall be conducted at site.

** For tenders of Electrical & Mechanical Works only*

- 33.2** Concrete cubes shall have to be casted by the contractor during construction of all RCC / PCC works and got them tested through IIT, Roorkee / Sri Ram Institute of Industrial Research, Delhi or any other Institution of repute designated by the Engineer / Employer, by the contractor at his own expense. Similarly, the Contractor may be required to get cement mortar or any such component of finished works tested. A proper record of all tests shall be maintained by the Contractor in a Testing Register, which may be required to be produced to the Engineer any time or as many time, as required. In addition, the Contractor shall submit to the Engineer all test reports in original as soon as they are received, copies of which may be retained by the Contractor for his own record. If any of the test reports doesn't conform to relevant Specifications / IS Standards, the contractor will demolish and reconstruct such defected works within shortest possible time, entirely at his own risk and cost. The number of samples to be tested will be decided as per the directions of Engineer. All the samples drawn from work shall be taken and sealed jointly by the Contractor / his Authorized Representative and the Engineer / his Authorized Representative.

- 33.3** All the water retaining structures and pipelines / sewer lines laid along with their appurtenant works shall have to be hydraulically tested by the contractor for detection of any seepage / leakages and their due performance under the required test conditions, in isolated sections to be determined by the Engineer, during progress of the works or after their completion. Such hydraulic testing shall be performed by the Contractor in presence of the Engineer or his Authorized Representative in the required manner and as per the specifications set out in the Specifications of Works including all necessary arrangements and supply of required equipments, at his own cost. Hydraulic testing shall be deemed to be satisfactorily accomplished, only when it is duly signed / countersigned by the Engineer. A proper record of all tests shall be maintained by the Contractor in a Testing Register, which may be required to be produced to the Engineer at any time or as many time, as required. In addition, the Contractor shall submit to the Engineer all test reports in original as soon as they are received, copies of which may be retained by the Contractor for his own record. If any of the test reports doesn't conform to relevant Specifications / IS Standards, the contractor will

demolish and reconstruct such defected works within shortest possible time, entirely at his own risk and cost.

- 33.4** Execution of any water retaining structure or pipeline work with appurtenant structures shall be deemed to be completed only after their satisfactory completion, followed by their hydraulic testing as per the provisions of Sub Cl. 33.3 above. Such works shall not be treated as actually completed unless the certificate of hydraulic testing has been furnished by the Contractor and duly signed / countersigned by the Engineer and a mention to this effect has been recorded on the measurement book after recording measurements of the concerned works.
- 33.5** Water required for construction, curing, testing etc., if not available through the executed works, shall have to be arranged by the Contractor from his own sources and at his own cost. No responsibility in this regard shall lie on the Engineer / Employer / Owner.
- 33.6** If the Engineer instructs the Contractor to carry out any test not specified in the Specifications to check any component of work, equipment, machinery etc. for its due performance or a possible defect / shortcoming and the test shows that it doesn't conform to the desired specifications / performance or found to have a defect / shortcoming, then the Contractor shall pay all expenditure incurred in connection with such tests and shall rectify the defect / shortcoming immediately, and if it is not possible then shall dismantle / demolish / remove such works, equipments, machinery etc. from the site of works at the earliest and entirely at his own risks and costs.

34. Completion and Commissioning of Work

- 34.1** The Contractor shall ensure to complete and commission the work up to date of Intended Completion date as defined in Contract Data. One month before the end of completion period, the Contractor shall request the Engineer to issue a certificate of completion of the works and the Engineer will do so after inspecting the works by himself / Higher Authorities / Govt. Technical Audit / Third Party Quality Control team and certify that the work has been completed as per the specifications within the completion period as defined in the Contract Data.

Note: Where in certain cases, the technical specifications provide for acceptance of works within specified tolerance limits at reduced rates, Engineer will certify payments to Contractor accordingly.

35. Correction of Defects

- 35.1** The Engineer shall give notice to the Contractor of any Defects noticed during the Defects Liability Period, which begins after the date of successful Completion and is defined in the Contract Data.

35.2 Every time notice of a Defect is given, the Contractor shall correct the notified Defect within the length of time specified in the Engineer's notice.

36. Uncorrected Defects

36.1 If the Contractor has not corrected a Defect within the time specified in the Engineer's notice, the Engineer will get the Defects corrected at the Contractor's cost and the cost so incurred will be debitable from pending bills due to the Contractor and the retention money.

D. Cost Control

37. Bill of Quantities

37.1 The Bill of Quantities shall contain items for the construction, installation, testing, commissioning, maintenance & handing over of work to be done by the contractor as defined in Section-XI (Bill of Quantities).

37.2 The Bill of Quantities is used to calculate the Contract Price. The Contractor is paid for the quantity of the work done at the rate in the Bill of Quantities for each item. For Lump Sum contracts / items, the payment shall be made as per the payment schedule.

38. Changes in the Quantities

38.1 If the quantity of the work to be executed differs from the quantity in the Bill of Quantities for the particular item, it should be brought to the notice of the Engineer by the contractor before the execution of work. After verification, he will approve or seek the approval of the competent authority for such variations in quantities of the contract.

38.2 If requested by the Engineer, the Contractor shall provide the Engineer with a detailed cost breakdown of any rate in the Bill of Quantities.

39. Variations

39.1 All Variations shall be included in updated Programs produced by the Contractor.

40. Payments for Variations

40.1 The Engineer shall assess the quotation, which shall be given within seven days of the request or within any longer period stated by the Engineer and before the Variation is ordered.

40.2 If the work in the Variation corresponds with an item description in the Bill of Quantities and if, in the opinion of the Engineer, the quantity of work is above the limit stated in Sub Cl. 37.1, the rate in the bill of Quantities shall be used to calculate the value of the Variation.

- 40.3** The Contractor shall provide the Engineer with a quotation (with breakdown of unit rates) for carrying out the Variation.
- 40.4** If the Contractor's quotation is unreasonable (or if the contractor fails to provide the Engineer with a quotation within a reasonable time specified by the engineer in accordance with Sub Cl. 40.1), the Engineer may order the Variation and make a change to the Contract Price which shall be based on the prevent schedule of rates.

41. Cash flow forecasts

- 41.1** When the Program is updated, the contractor is to provide the Engineer with an updated cash flow forecast.

42. Payment Certificates

- 42.1** The Contractor shall submit to the Engineer monthly statements of the estimated value of the work completed less the cumulative amount certified previously along with details of measurement of the quantity of works executed in a tabulated form as approved by the Engineer.
- 42.2** The Engineer shall check the details given in the Contractor's monthly statement and certify the amounts to be paid to the Contractor after taking into account any credit or debit for the month in question in respect of materials for the works in the relevant amounts and under conditions set forth in Sub Cl. 51.4 of G.C.C. and Contract Data (Secured Advance).
- 42.3** The value of work executed shall be determined by the Engineer after due check measurement of the quantities claimed as executed by the contractor.
- 42.4** The value of work executed shall comprise the value of the quantities of the items in the Bill of Quantities completed.
- 42.5** The value of work executed shall include the valuation of Variations and Compensation Events.
- 42.6** The Engineer may exclude any item certified and paid earlier in a previous certificate or reduce the proportion of any item previously certified if it comes to his knowledge later on to do so.

43. Payments

- 43.1** Payments shall be adjusted for deductions of advance payments, retention, other recoveries in terms of the contract and taxes, at source, as applicable under the law. The Employer shall pay the Contractor, the amounts certified by the Engineer as early as possible.
- 43.2** Payment schedule will be as per Sub Cl. 42.1 except for items covering lump sum items like Building Works such as Pump House & Staff Quarter, Sump /

Service Reservoir (Capacity 60 KL or more) & Filter Plant. The payment schedule for these items will be as follows –

1. Building Works (Pump House / Staff Quarter)

- (a) On reaching Roof level : 40 % of total cost
- (b) On Completion of work : 60 % of total cost

2. Sump / Service Reservoir (Capacity 60 KL & more)

- (a) Casting of vertical wall : 40 % of total cost
- (b) Casting of Roof Slab & Completion of misc. works such as remaining stair case, MS ladder, ventilator, water level indicator, lightening conductor, fixing of pipes etc. : 45 % of total cost
- (c) Testing of tank for water tightness and construction of floor and drain, painting and finishing of the entire work : 15 % of total cost

3. Filter Plant

- (a) Approval of design and drawing by the competent authority : 2 % of total cost
- (b) Completion of civil works of Pre settling tank, inlet Chambers and clariflocculator : 20 % of total cost
- (c) Completion of civil works of hopper bottom settling tank, rapid gravity filter and clear water sump : 25 % of total cost
- (d) Completion of back wash tank : 13 % of total cost
chemical house, filter house and rest civil works
- (e) Installation of mechanical Equipment, fixing of strainer System, piping arrangement, Discharge measuring devices, Filter media filling, back wash System, fixing of valves and Other fittings, painting snowsem etc. : 20 % of total cost
- (f) Testing & trial run for 1 month : 20 % of total cost

43.2* For Electrical & Mechanical Works, Payment schedule will be as follows –

1. 90% payment on supply of goods at site.
2. 10% payment on erection, commissioning & testing of equipments.

** For tenders of Electrical & Mechanical Works only*

44. Compensation Events

- 44.1** The following are Compensation Events unless they are caused by the Contractor:
- (a) The Employer does not give access to a part of the Site by the Site Possession Date stated in the Contract Data.
 - (b) The Employer modifies the schedule of other contractors in a way which affects the work of the contractor under the contract. In case it relates with the work under the contract.
 - (c) The Engineer orders a delay or does not issue drawings, specifications or instructions required for execution of works in time.
- 44.2** If a Compensation Event would prevent the work being completed before the Intended Completion Date, the Intended Completion Date is extended. The Engineer shall decide whether and by how much the Intended Completion Date shall be extended.
- 44.3** The Contractor shall not be entitled to compensation to the extent that the Employer's interests are adversely affected by the Contractor not having given early warning or not having cooperated with the Engineer.

45. Tax

- 45.1** The rates quoted by the Contractor shall be deemed to be inclusive of the sales and other taxes including VAT etc. that the Contractor will have to pay for the performance of this Contract. The Employer will perform such duties in regard to the deduction of such taxes at source as per applicable law.

46. Currencies

- 46.1** All payments shall be made in Indian Rupees.

47. Appreciation

- 47.1** If the Contractor achieves completion of the Works prior to the time prescribed in Contract Data, the Employer shall issue an appreciation letter to the Contractor / Bidder.

48. Retention

- 48.1** The Employer shall retain from each payment due to the Contractor the proportion stated in the Contract Data until Completion of the whole of the Works.
- 48.2** The total amount retained will be paid to the Contractor when the Defects Liability Period is passed and the Engineer has certified that all Defects notified by the Engineer to the Contractor before the end of this period have been corrected.

49. Liquidated Damages

- 49.1** The Contractor shall pay liquidated damages to the Employer at the rate per day stated in the Contract Data for each day that the Completion Date is later than the Intended Completion Date (for the whole of the works or the milestone as stated in the contract data). The total amount of liquidated damages shall not exceed the amount defined in the Contract Data. The Employer may deduct liquidated damages from payments due to the Contractor. Time is the essence of the contract and payment or deduction of liquidated damages shall not relieve the contractor from his obligation to complete the work as per agreed construction program and milestones or from any other of the contractor's obligations and liabilities under the contract.
- 49.2** If the Intended Completion Date is extended after liquidated damages have been paid, the Engineer shall correct any overpayment of liquidated damages by the Contractor by adjusting the next payment certificate.

50. Penalty

- 50.1*** 5% value of pump for each and every one tenth of B.O.T. above guaranteed figures shall be levied by as a penalty. However no damages shall be claimed if the consumption is less than 0.05 B.O.T. above guaranteed figures otherwise pro rata reduction shall be made. The pumping plant will be accepted up to the allowable limit of +/- 4% discharge without imposing any penalty. If discharge found less than 5% to 14% pro rata reduction at the rate of 1% of the cost of pumps and motors for less percentage of discharge will be made. If the discharge is found less by 15%, the pumping plant will be rejected and cost of it will be recovered from the contractor.

** For tenders of Electrical & Mechanical Works only*

51. Advance Payment

- 51.1** The Employer shall make advance payment to the Contractor of the amounts stated in the Contract Data by the date stated in the Contract Data, against provision by the Contractor of an Unconditional Bank Guarantee in a form and by a bank acceptable to the Employer in amounts and currencies equal to the advance payment. The guarantee shall remain effective until the advance payment has been repaid, but the amount of the guarantee shall be progressively reduced by the amounts repaid by the Contractor. Interest will not be charged on the advance payment.
- 51.2** The Contractor is to use the advance payment only to pay for Equipment, Plant and Mobilization expenses required specifically for execution of the Works. The Contractor shall demonstrate that advance payment has been used in this way by supplying copies of invoices or other documents to the Engineer.

51.3 The advance payment shall be repaid by deducting proportionate amounts from payments otherwise due to the Contractor, following the schedule of completed percentages of the Works on a payment basis.

51.4 Secured Advance:

The Engineer shall make advance payment in respect of materials intended for but not yet incorporated in the Works in accordance with conditions stipulated in the Contract Data.

52. Securities

52.1 The Performance Security shall be provided to the Employer no later than the date specified in the Letter of Acceptance and shall be issued in an amount and form and by a bank or surety acceptable to the Employer, and denominated in Indian Rupees. The Performance Security shall be valid until a date 28 days from the date of expiry of Defects Liability Period and the additional security for unbalanced bids shall be valid until a date 28 days from the date of issue of the certificate of completion.

53. Cost of Repairs

53.1 Loss or damage to the Works or Materials to be incorporated in the Works between the Start Date and the end of the Defects Correction periods shall be remedied by the Contractor at the Contractor's cost if the loss or damage arises from the Contractor's acts or omissions.

E. Finishing the Contract

54. Completion

54.1 The Contractor shall request the Engineer to issue a Certificate of Completion of the Works and the Engineer will do so upon deciding that the Work is completed in accordance with Cl. 34.

55. Taking Over

55.1 The Employer shall take over the Site and the Works within seven days of the Engineer issuing a certificate of Completion

56. Final Account

56.1 The Contractor shall supply to the Engineer a detailed account of the total amount that the Contractor considers payable under the Contract before the end of the Defects Liability Period. The Engineer shall issue a Defect Liability Certificate stating that the all the defects have been rectified and certify any final payment that is due to the Contractor within 60 days of receiving the Contractor's account if it is correct and complete. If it is not, the Engineer shall issue within 60 days a schedule that states the scope of the corrections or additions that are necessary. If the Final Account is still

unsatisfactory after it has been resubmitted, the Engineer shall decide on the amount payable to the Contractor and issue a payment certificate, within 60 days of receiving the Contractor's revised account.

57. Drawing / Manuals

57.1 If the Contractor does not supply the Drawings and / or manuals by the dates stated in the Contract Data, or they do not receive the Engineer's approval, the Engineer shall withhold the amount stated in the Contract Data from payments due to the Contractor.

58. Termination

58.1 The Employer may terminate the Contract if the other party causes a fundamental breach of the Contract, or any other reason thereof.

58.2 Fundamental breaches of Contract include, but shall not be limited to the following:

- (a) the Contractor stops work for 28 days when no stoppage of work is shown on the current program and the stoppage has not been authorized by the Engineer;
- (b) the Contractor is made bankrupt or goes into liquidation other than for a reconstruction or amalgamation;
- (c) the Engineer gives Notice to correct a particular Defect and the Contractor fails to correct it within the specified period of time determined by the Engineer;
- (d) the Contractor does not maintain a security of the works executed or in progress;
- (e) the Contractor has delayed the completion of works by the number of days for which the maximum amount of liquidated damages can be paid as defined in the Contract data;
- (f) if the Contractor, in the judgment of the Purchaser has engaged in fraud and corruption, as defined in GCC Cl. 62, in competing for or in executing the Contract, and
- (g) if the contractor is Joint Venture and the lead partner becomes defaulter in the execution of works under contract,
- (h) The Contractor has contravened Cl. 7 of GCC read with SCC and Cl. 9 of GCC
- (i) The contractor does not adhere to the agreed construction program (Cl. 27 of GCC) and also fails to take satisfactory remedial action as per

agreements reached in the management meetings (Cl. 30) for a period of 60 days.

- (j) The contractor fails to carry out the instructions of Engineer within the specified time determined by the Engineer in accordance with GCC Sub Cl. 16.1 and 23.1.

58.3 Notwithstanding the above, the Employer may terminate the Contract for convenience.

58.4 If the Contract is terminated the Contractor shall stop work immediately, handover the site along with the work executed and materials available at the site up to the date of termination. The Engineer shall immediately takeover the site along with the materials on 'As is where is basis' and make it safe and scare.

58.5 Fundamental breach of contract by the contractor may result into following consequences, as decided by the Engineer / Employer:-

- i. Performance security submitted by the contractor can be forfeited.
- ii. Rescind the contract (of which recession notice in writing to the contractor under the hand of the Engineer shall be conclusive evidence) and in which case the security deposit of the contractor together with such sum or sums due to him under the contract shall stand forfeited and be absolutely at the disposal of the Engineer.
- iii. Determine the contract and call in other contractor, or employ daily labour to dismantle bad work if necessary (the bad work to be certified by the Engineer whose decision shall be final) and to renew and complete the said works and pay the cost of such contractor for daily labour and price of materials required for such dismantling, renewing and completion out of the said security deposit or such sum or sums as may be due to the contractor under this contract, and if such sum or sums due to the contractor under this contract, and if such cost be more than the amount made up the security money and the sum or sums due to the contractor under this contract the difference between it and the sum made up by the security money and the balance due to the contractor as aforesaid shall be a debt due from the said contractor.
- iv. Take legal action against the contractor if the breach of the contract is related to Fraud and Corruption as per Sub Cl. 58.2 (f).
- v. Blacklist the Contractor and debar him for award of any contract in Uttarakhand Peyjal Nigam.

In the event of either of the above courses being adopted by the Engineer, the contractor shall have no claim for compensation for any loss sustained by him by reason of his having purchased or procured any materials, or entered into any agreement, or made any advance on account of, or with a view to the execution of the work or the performance of the contract. And in case the contract shall be rescinded under the provision aforesaid, the contractor shall not be entitled to recover or be paid any sum for any work therefore actually performed under this contract, unless and

until the Engineer certifies in writing the performance of such work and the value payable in respect thereof.

59. Payment upon Termination

59.1 If the Contract is terminated because of a fundamental breach of Contract by the Contractor, the Engineer shall issue a certificate for the value of the work done less advance payments received up to the date of the issue of the certificate, less other recoveries due in terms of the contract, less tax due to be deducted at source as per applicable law and less the penalty to be imposed as per the rates as indicated in the Contract Data. Additional Liquidated Damages shall not apply. If the total amount due to the Employer exceeds any payment due to the Contractor the difference shall be a debt payable to the Employer.

60. Property

60.1 All materials on the Site, Plant, Equipment, Temporary Works and Works are deemed to be the property of the Employer, if the Contract is terminated because of a Contractor's default. The Engineer will assess the cost of utilizable materials lying at site, which will be final and binding to the contractor and will be deemed to be the property of the department. The Engineer will be free to use the materials for the past under project or any other project.

61. Release from Performance

61.1 If the Contract is frustrated by the outbreak of war or by any other event entirely outside the control of either the Employer or the Contractor the Engineer shall certify that the Contract has been frustrated. The Contractor shall make the Site safe and stop work as quickly as possible after receiving this certificate and shall be paid for all work carried out before receiving it and for any work carried out afterwards to which commitment was made.

62. Fraud and Corruption

62.1 The Employer requires that Bidders, Suppliers, Contractors, and Consultants under this contract, observe the highest standard of ethics during the procurement and execution of such contracts. In pursuit of this policy, the Employer:

- (a) defines, for the purposes of this provision, the terms set forth below as follows:
 - (i) "corrupt practice" means the offering, giving, receiving, or soliciting, directly or indirectly, of anything of value to influence the action of a public official in the procurement process or in contract execution;

- (ii) “fraudulent practice” means a misrepresentation or omission of facts in order to influence a procurement process or the execution of a contract;
 - (iii) “collusive practice” means a scheme or arrangement between two or more Bidders, with or without the knowledge of the borrower, designed to establish bid prices at artificial, non competitive levels; and
 - (iv) “coercive practice” means harming or threatening to harm, directly or indirectly, persons or their property to influence their participation in the procurement process or affect the execution of a contract;
- (b) will sanction a firm or individual, including declaring them ineligible, either indefinitely or for a stated period of time, to be awarded a contract by Uttarakhand Peyjal Nigam if it at any time determines that they have, directly or through an agent, engaged, in corrupt, fraudulent, collusive or coercive practices in competing for, or in executing, a contract by Uttarakhand Peyjal Nigam; and
 - (c) will have the right to require that Contractors to permit the Employer to inspect their accounts and records and other documents relating to the bid submission and contract performance and to have them audited by auditors appointed by the Employer.

F. Special Conditions of Contract

1. LABOUR :

The Contractor shall, unless otherwise provided in the Contract, make his own arrangements for the engagement of all staff and labour, local or other, and for their payment of wages, housing and transport

The Contractor shall, if required by the Engineer, provide the details of worker men employed by the Contractor on the Site.

During the Construction of work, the contractor shall give preference to local labour.

2. COMPLIANCE WITH LABOUR REGULATIONS :

During continuance of the contract, the Contractor and his sub contractors shall abide at all times by all existing labour enactments and rules made thereunder, regulations, notifications and bye laws of the State or Central Government or local authority and any other labour law (including rules), regulations, bye laws that may be passed or notification that may be issued under any labour law in future either by the State or the Central Government or the local authority. Salient features of some of the major labour laws that are applicable to construction industry are given below. The Contractor shall keep the Employer indemnified in case any action is

taken against the Employer by the competent authority on account of contravention of any of the provisions of any Act or rules made thereunder, regulations or notifications including amendments. If the Employer is caused to pay or reimburse, such amounts as may be necessary to cause or observe, or for non-observance of the provisions stipulated in the notifications/bye laws/Acts/Rules/regulations including amendments, if any, on the part of the Contractor, the Engineer/Employer shall have the right to deduct any money due to the Contractor including his amount of performance security. The Employer/Engineer shall also have right to recover from the Contractor any sum required or estimated to be required for making good the loss or damage suffered by the Employer.

The employees of the Contractor and the Sub-Contractor in no case shall be treated as the employees of the Employer at any point of time.

**SALIENT FEATURES OF SOME MAJOR LABOUR LAWS APPLICABLE
TO ESTABLISHMENTS ENGAGED IN BUILDING AND OTHER
CONSTRUCTION WORK**
(The law as current or on the date of bid opening will apply)

- a) Workmen Compensation Act 1923: The Act provides for compensation in case of injury by accident arising out of and during the course of employment.
- b) Payment of Gratuity Act 1972: Gratuity is payable to an employee under the Act on satisfaction of certain conditions on separation if an employee has completed 5 years service or more or on death the rate of 15 days wages for every completed year of service. The Act is applicable to all establishments employing 10 or more employees.
- c) Employees P.F. and Miscellaneous Provision Act 1952 (since amended): The Act Provides for monthly contributions by the employer plus workers @ 10% or 8.33%. The benefits payable under the Act are :
 - (i) Pension or family pension on retirement or death, as the case may be.
 - (ii) Deposit linked insurance on the death in harness of the worker.
 - (iii) payment of P.F. accumulation on retirement/death etc.
- d) Maternity Benefit Act 1951: The Act provides for leave and some other benefits to women employees in case of confinement or miscarriage etc.
- e) Contract Labour (Regulation & Abolition) Act 1970: The Act provides for certain welfare measures to be provided by the Contractor to contract labour and in case the Contractor fails to provide, the same are required to be provided, by the Principal Employer by Law. The Principal Employer is required to take Certificate of Registration and the Contractor is required to take license from the designated Officer. The Act is applicable to the establishments or Contractor of Principal Employer if they employ 20 or more contract labour.

- f) Minimum Wages Act 1948: The Employer is supposed to pay not less than the Minimum Wages fixed by appropriate Government as per provisions of the Act if the employment is a scheduled employment. Construction of Buildings, Roads, Runways are scheduled employments.
- g) Payment of Wages Act 1936: It lays down as to by what date the wages are to be paid, when it will be paid and what deductions can be made from the wages of the workers.
- h) Equal Remuneration Act 1979: The Act provides for payment of equal wages for work of equal nature to Male and Female workers and for not making discrimination against Female employees in the matters of transfers, training and promotions etc.
- i) Payment of Bonus Act 1965: The Act is applicable to all establishments employing 20 or more employees. The Act provides for payments of annual bonus subject to a minimum of 8.33% of wages and maximum of 20% of wages to employees drawing Rs.3500/-per month or less. The bonus to be paid to employees getting Rs.2500/- per month or above upto Rs.3500/- per month shall be worked out by taking wages as Rs.2500/-per month only. The Act does not apply to certain establishments. The newly set-up establishments are exempted for five years in certain circumstances. Some of the State Governments have reduced the employment size from 20 to 10 for the purpose of applicability of this Act.
- j) Industrial Disputes Act 1947: The Act lays down the machinery and procedure for resolution of Industrial disputes, in what situations a strike or lock-out becomes illegal and what are the requirements for laying off or retrenching the employees or closing down the establishment.
- k) Industrial Employment (Standing Orders) Act 1946: It is applicable to all establishments employing 100 or more workmen (employment size reduced by some of the States and Central Government to 50). The Act provides for laying down rules governing the conditions of employment by the Employer on matters provided in the Act and get the same certified by the designated Authority.
- l) Trade Unions Act 1926: The Act lays down the procedure for registration of trade unions of workmen and employers. The Trade Unions registered under the Act have been given certain immunities from civil and criminal liabilities.
- m) Child Labour (Prohibition & Regulation) Act 1986: The Act prohibits employment of children below 14 years of age in certain occupations and processes and provides for regulation of employment of children in all other occupations and processes. Employment of Child Labour is prohibited in Building and Construction Industry.
- n) Inter-State Migrant workmen's (Regulation of Employment & Conditions of Service) Act 1979: The Act is applicable to an establishment which employs 5 or more inter-state migrant workmen through an intermediary (who has recruited

workmen in one state for employment in the establishment situated in another state). The Inter-State migrant workmen, in an establishment to which this Act becomes applicable, are required to be provided certain facilities such as housing, medical aid, traveling expenses from home upto the establishment and back, etc.

- o) The Building and Other Construction workers (Regulation of Employment and Conditions of Service) Act 1996 and the Cess Act of 1996: All the establishments who carry on any building or other construction work and employs 10 or more workers are covered under this Act. All such establishments are required to pay cess at the rate not exceeding 2% of the cost of construction as may be modified by the Government. The Employer of the establishment is required to provide safety measures at the Building or construction work and other welfare measures, such as Canteens, First-Aid facilities, Ambulance, Housing accommodations for workers near the work place etc. The Employer to whom the Act applies has to obtain a registration certificate from the Registering Officer appointed by the Government.
- p) Factories Act 1948: The Act lays down the procedure for approval at plans before setting up a factory, health and safety provisions, welfare provisions, working hours, annual earned leave and rendering information regarding accidents or dangerous occurrences to designated authorities. It is applicable to premises employing 10 persons or more with aid of power or 20 or more persons without the aid of power engaged in manufacturing process.

Salient features of some of the major laws that are applicable are given below :

The Water (Prevention and Control of Pollution) Act, 1974, This provides for the prevention and control of water pollution and the maintaining and restoring of wholesomeness of water. 'Pollution' means such contamination of water or such alteration of the physical, chemical or biological properties of water or such discharge of any sewage or trade effluent or of any other liquid, gaseous or solid substance into water (whether directly or indirectly) as may, or is likely to, create a nuisance or render such water harmful or injurious to public health or safety, or to domestic, commercial, industrial, agricultural or other legitimate uses, or to the life and health of animals or plants or of aquatic organisms.

The Air (Prevention and Control of Pollution) Act, 1981, This provides for prevention, control and abatement of air pollution. 'Air Pollution' means the presence in the atmosphere of any 'air pollutant', which means any solid, liquid or gaseous substance (including noise) present in the atmosphere in such concentration as may be or tend to be injurious to human beings or other living creatures or plants or property or environment.

The Environment (Protection) Act, 1986, This provides for the protection and improvement of environment and for matters connected therewith, and the prevention of hazards to human beings, other living creatures, plants and property. 'Environment' includes water, air and land and the inter-relationship which exists among and between water, air and land, and human beings, other living creatures, plants, micro-organism and property.

The Public Liability Insurance Act, 1991, This provides for public liability insurance for the purpose of providing immediate relief to the persons affected by accident occurring while handling hazardous substances and for matters connected herewith or incidental thereto. Hazardous substance means any substance or preparation which is defined as hazardous substance under the Environment (Protection) Act 1986, and exceeding such quantity as may be specified by notification by the Central Government.

SECTION - V

SPECIFICATIONS

Technical Specification for Civil Works

INDEX

1	General	69
2	Earthwork And Excavation	77
3	Anti Termite Treatment	86
4	Concrete And Allied Works	88
5	Formwork	122
6	Reinforcement	128
7	Structural Steel Work	131
8	Brick Work And Stone Masonry	136
9	Plastering	143
10	Flooring	145
11	Distempering And Painting	154
12	Expansion Joints And Construction Joints	161
13	Epoxy Coating And Bituminous Painting	164
14	Door, Windows, Grills, Shutters, etc.	166
15	Hand Railing	169
16	Rungs	170
17	Intake Well	171
18	Infiltration Galleries	180
19	Bored Well	181
20	Water Treatment Plant	182
21	Clear Water Sump (Reservoir)	189
22	Pump House	190
23	Pipeline Work	191
24	Valves	203
25	Water Supply and Sanitary Works	212

List of Tables

Table 1: List of IS

Table 2: Foreign Material Limitations in Fine Aggregate

Table 3: Grading of Sand for Fine Aggregate

Table 4 : Foreign Material Limitations in Coarse Aggregate

Table 5: Grade of Concrete

Table 6: Compressive Strengths at 28 days

Table 7: Minimum Cement Content in Concrete

Table 8: Limits of Consistency

Table 9 : Types of Water Stops

Table 10 : Proportions for Standard Grout

Table 11 : Proportions for Non-Shrinking Grout

Table 12 : Period for Formwork

Table 13 : Sizes of Terrazzo Tiles

PREAMBLE

The "Specifications" are to be read for the purpose of pricing in conjunction with "Conditions of Contract" of the Tender Documents containing Instructions to Bidder and General Conditions of Contract; and "Financial Bid" of this tender.

The prices quoted in the Financial Bid shall be all inclusive of value for the work described including all costs and expenses which may be required in and for the execution of the work described together with all general risks, liabilities and obligations set forth or implied in the document on which the tender is based.

All works shall be carried out strictly as per detailed specifications whether actually specified or not. If not specified work shall be carried out as per directions of Owner / Engineer.

The total amount entered in the Financial Bid shall be written in ink and shall be entered both in figures and words.

Specifications of items of work described in BOQ for each item shall read this in conjunction with other technical specifications and specific technical requirements and quote accordingly.

No separate payment whatsoever shall be made for dewatering if required to be done during excavation, laying of PCC and RCC laying and jointing of pipes, construction of manholes, testing and backfilling etc. and hence Contractor should quote accordingly.

If the bidder needs any clarification, they shall obtain the same in writing from Owner / Engineer. No notice will be taken of any verbal discussions in such matters.

Abbreviations used in this Specifications document have the meanings shown below:

mm	Millimetre	CI	Cast Iron
cm	Centimetre	GI	Galvanized Iron
M	Metre	GSW	Glazed Stone Ware
km	Kilometre	BBCC	Burnt Brick Cement Concrete
sq.m	Square Metre	RCC	Reinforced Cement Concrete
cum.	Cubic Metre	PCC	Plain Cement Concrete
M.T.	Metric Ton	wt	Weight
SWG	Standard Wire Gauge	kg	Kilogram
R.M.	Running Metre	I.D.	Internal Diameter
nos.	Numbers	C.M.	Cement Mortar
MS	Mild Steel	IS	Indian Standards
M.D	Metre Depth of Manhole	SS	Stainless Steel

General

Specifications & Drawings

The drawings of the proposed work(s)/plant(s) are incorporated in tender documents. These drawings are made for Tenderer's guidance only.

The Contractor will have to submit detailed design as well as General Arrangement drawings and structural drawings to the Engineer-in-Charge and obtain prior approval to start the construction, erection and commissioning of civil, electrical and mechanical components of the water supply scheme.

Work shall be carried out by Contractor exactly in accordance with the Drawings marked as RELEASED FOR CONSTRUCTION and approved by Engineer-in-Charge and as per the instructions of the Engineer-in-Charge in writing.

Materials

The term "Materials" shall mean all materials, goods and articles of every kind whether raw, processed or manufactured and equipment and plant of every kind to be supplied by the Contractor for incorporation in the works.

Except as may be otherwise specified for particular parts of the Works the provision of clauses in "materials and workmanship" shall apply to materials and workmanship for any part of the works.

All materials shall be new and of the kinds and qualities described in the Contract and shall be approved by the Engineer in-charge.

Materials shall be transported, handled and stored in such a manner as to prevent deterioration, damage or contamination failing which such damaged materials will be rejected and shall not be used on any part of the Works under this contract.

Standards

The special attention of the Contractor is drawn to the relevant sections and clauses of the National Building Code of India 1984 & PWD specifications and latest BIS Codes (Latest editions along with amendments) and should follow them strictly in addition to the specifications & conditions stipulated in this volume.

Materials and workmanship shall comply with the relevant Indian Standards (with amendments), unless a more recent amendment is specified hereinafter, or with the requirements of any other authoritative standard approved by the Engineer-in-Charge which shall be no less exacting in the opinion of the Engineer-in-Charge than the corresponding standard quoted here in.

The specifications, standards and codes listed below are made a part of this specification. All standards, tentative specifications, specifications, codes of practice referred to herein shall be the latest editions including all applicable official amendments and revisions.

If no standard is indicated, the relevant Indian Standard, if any, shall apply. Indian standards are published by BIS.

Hand Book (1990) shall be followed, wherever not specified in this "Volume II: Technical Specifications", IS specifications shall be applicable. In case of discrepancy Engineer-in-Charge's decision will be final & binding.

List of Important Indian Standards

The following list includes various Indian Standards which are IMPORTANT and are referred to in the general specifications and used in construction works. These standards are to be strictly adhered to unless otherwise is applicable in the relevant context. These standards are to be followed both in respect of materials and construction of civil engineering works included in the tenders.

Though the list of Indian Standards includes the year of Publication of the standard, it may not in all cases be the latest. It is obligatory that only the latest edition of the standard is referred to and followed, along with all amendments and revisions issued with respect to the standard under consideration. This list is not exhaustive but contains only the standards that are very frequently used on the construction works. If a standard exists for a particular item of material or equipment or code of practice the same shall be followed whether the same is included in this list, specifications, other parts of the tender documents or not. Some Indian Standards are referred to in the specifications/ drawings/ other parts of the tender documents and they are supplementing this list if they do not find a place in the list.

Table 1: List of IS

S.No.	IS Code No. / Year	Title
1	2062-1984	Specification for Structural Steel (Fusion Welding Quality)
2	269-1976	Ordinary and low heat Portland cement
3	383-1970	Coarse and fine aggregates from natural sources for concrete
4	432(part1)-1982	Mild steel and medium tensile steel bars
	455-1976	Portland slag cement
6	456	Code of practice for plain and reinforced cement concrete
7	516-1959	Methods of test for strength of concrete
8	800-1984	Code of practice for general construction in steel
9	816-1969	Code of practice for use of metal arc welding for general construction in mild steel
10	1038-1983	Steel-doors, windows and ventilators
11	1077-1986	Common burnt clay building bricks
12	1199-1959	Methods of sampling and analysis of concrete
13	1200 (part1-26)	Method of measurement of building and civil engineering works
14	1477 (part 1-2)	Code of practice for painting of ferrous metals in buildings
15	1542-1977	Sand of plaster
16	1726 (part 1,2 & 4)	Cast iron manhole covers and frames
17	1786-1985	High strength deformed steel bars and wires for concrete reinforcement
18	2116-1980	Sand for masonry mortars
19	2212-1962	Code of practice for brickwork
20	2250-1981	Code of practice for preparation and use of masonry mortars
21	2386 (part I-VIII)	Methods of tests for aggregate for concrete
22	2502-1963	Code of practice for bending and fixing of bars for reinforced concrete
23	2720 (part	Methods of test for soil

S.No.	IS Code No. / Year	Title
	IV, VIII)	
24	3370 (part I-IV)	Code of practice for concrete structures for the storage of liquids
25	3696	Safety code for scaffolds and ladders
26	3764-1966 (part 1-2)	Safety code for excavation work
27	4082-1977	Recommendations on stacking and storage of construction materials at site
28	6248-1979	Metal rolling shutters and rolling grills
29	7293-1974	Safety code for working with construction machinery
30	7969-1975	Safety code for handling and storage of building materials
31	Code	National Building Code of India
32	4014	Code of practice for steel tubular scaffolding.
33	5121	Code of practice for deep foundation
34	3764	Safety code for excavation work
35	4082	Recommendations on stocking & storage material at site.
36	7293	Safety code of working with construction machinery.
37	7364	Plastic pipe work for potable water supply (part I-III)
38	IS 3589-1981	ERW Pipes
39	1239 Part 1	GI Pipes

Indian Standards Institution
Manak Bhavan
9, Bahadur Shah Zafar Marg
New Delhi - 110 002.

General Specifications

The contract shall be deemed to be completed when all the works described in the specifications and set out in schedules have been successfully completed, tested and maintenance period of one year from the date of completion and handing over to the department is over.

The Engineer will establish the necessary bench marks and levels but the contractor must set out the works and he will responsible for its correctness and it shall be incumbent him to dismantle, remove and rebuild at his own expenses work not correctly set out.

Further before ordering any materials, the contractor shall made his own conclusions as to the actual amount of materials as the payment will only be made on 'Net' measurement of the work actually completed.

The contractor shall provide all pegs, plates, pillars, required for setting out the work and shall give such as may be required by the Engineer or his authorized representative in fixing bench marks, giving levels and carrying works before, during & after execution of work.

As materials are collected and the construction of each section of the work is completed, it will be checked by the Engineer or his authorized representative. The representative of contractor shall ascertain from the Engineer's representative from time to time as to what part or portions he wishes to check over and passes but such approval shall

in no way relieve the contractor from any of his responsibility which shall not end until the contract has been completed.

During the progress of the work and the period of maintenance the contractor shall carry out such tests as in the opinion of the Engineer or his authorized representatives are necessary. The rates in BOQ shall include cost of such tests.

As the work proceeds the contractor shall submit Samples of materials for approval as may be required by the Engineer and all deliveries at the site shall not be below the standard of the samples. The contractor must tender in general in accordance with the requirements of these specification.

The contractor must fill in ink the rates and amount etc. in English in BOQ. He must write in words as well as in figure the rates and total cost of each item in the columns provided in BOQ. BOQ must also be signed by the contractor firms or a duly authorized agent acting on his behalf.

The contractor must carefully go through the conditions, specifications and items of contract and study the drawing before tendering. In cases of any absurdity he should apply to the Engineer-in-charge for its rectification as no excuse for want of knowledge for non-compliance of any part or portion of these specifications or terms of contract shall be considered.

Octroi charges on all materials supplied by the contractor for the work from outside the Municipal limits shall be paid by him to the Municipal Board in accordance with the Municipal Schedule of rates in force at the time the materials cross the Municipal barrier. The contractor shall consult the Municipal Schedule of rates and make an allowance for the claim in his rates as no extra claim on account of it shall be entertained.

In item wise contract, firm prices in rupees and paisa shall be quoted for each item in the BOQ and in a manner as indicated in the tender, tender shall remain good and open for acceptance for a period of three calendar months from the date they are opened.

The contractor shall, before tendering, consider the all aspect of work and shall also arrange for supply of drinking water to his own employee and labour. All such facilities as are required to be provided for the labours under the labour welfare Rules in force shall be provided by the contractor at his own cost.

The contractor shall be responsible for fencing off in a good and sufficient manner all excavating works and materials at site so as to prevent accidents by night as well as during day time. He shall also be responsible for lighting up in a proper and sufficient manner at night for the portion of the work which is open or under construction. He shall appoint sufficient number of watchmen on duty when his workers are not actually working, to safeguard work and the materials. He should make his rates sufficiently comprehensive to allow for these duties. In case of accidents caused by the neglect of such precautions contractor shall be fully responsible.

Notice boards shall be supplied and fixed in suitable positions where the road or other through fares have been opened out for the construction work, and the traffic has to be diverted or cautioned. Such board shall display in large letters in black and white or in red and white such warnings as road-closed, drive slow, work ahead etc.

Note: - All caution Boards considered or directed by the Engineer in charge shall be provided by the contractor at his own cost as and when required and in case it is observed by the Engineer that due care in display of board not taken by the contractor. The Engineer reserves the right to set another board fixed, chargeable to the contractor.

The contractor will provide for partiers at each of portion of the road under repair and red flag shall be placed at each barrier by day and Red Light by night. The contractor must include in his rates necessary charges direr sum required for diversion of traffic. And all such diversions shall be maintained neat and clean, well rammed and watered.

The contractor shall provide at his own expense a tip for surplus earth and shall include in his rates a sufficient sum to cover the cartage and disposal charges in this connection.

The contractor shall include in his rates a sufficient amount to cover the cost of all temporary bridges and channel across trenches or excavations at the places considered necessary by the Engineer. He shall also provide for temporary diversion and reinstatement of all drains open or covered, or water mains that may be met with during the execution of the work.

All measurements connected with the work shall be taken geometrically or net and the dimensions given in BOQ shall be held to mean the finished size of the respective items of work.

The rates of supply, laying and joining of various pipe line e.g. G.I., M.S., C.I., A.C. & P.V.C., includes supply lowering laying, jointing, carting, testing & maintenance of all type of specials also e.g. G.I., M.S., C.I., A.C. & P.V.C. DIF & plane ended specials for which no extra payment in any manner shall be made to the contractor, however to account for above measurements for the pipe line work, for all types of pipes i.e. e.g. G.I., M.S., C.I., A.C. & P.V.C. and all class of pipes i.e. light, medium & heavy (suitable for different pressure) for the purpose of payments will be made from end to end without making any deductions for the length (s) occupied by such specials and fitting. In case of plain ended of D/F fittings, the rates of lowering, laying, jointing, testing and maintenance shall be treated included in pipe line laying, jointing works and for there no separates payment for these shall be made but the length (s) occupied by these shall be measured as explained above. No carting and fixing shall be paid. No separate payment on any account for above shall be entertained, as the rate of these are treated included in laying & joining of pipe line work, of respective included in laying & jointing of pipe line work, of respective item.

The quantities given in the BOQ are approximate and may vary. The payment will be made on actual "Net" measurements taken during construction and after completion of the works as per attached schedule. It is therefore, important that the contractor should order the exact quantity of materials required after working out his own quantities as he will not be paid for any materials ordered & procured but not used on work.

The work shall be paid for in manner set out in the general conditions here to annexed and at the rates stated deleted in BOQ.

MATERIALS (RAW & MANUFACTURED)

The contractor shall procure, provide and supply and include in his rates for all labour, materials, tools and plants required temporarily or permanently on the works that may become proper or necessary to complete the execution of the work in all respects.

The sand used on the "Works" for cement mortar, lime mortar, cement concrete and other purpose shall comply in every respect with public works department detailed specification No. 7 Part-I Section-DA (Buildings) of public works department.

These materials shall comply in every respect with the respective clauses of the P.W.D. detailed specification, Part-I Section-'A' (Buildings) which shall be deemed to be incorporated in this contract. Contractor shall be responsible for the safe cartage, storage and use of these materials.

All the joining materials used for laying jointing of C.I. S&S pipes and D/S pipe specials and fitting and also for G.I., M.S., A.C. & P.V.C. pipes & specials shall be arranged by the contractor. These will be subject to the approval of the Engineer. The lead used shall be of the best quality B.M. refined soft pig virgin lead and shall be obtained from an approved stockiest or manufacturer. The spun-yern shall be of best machine made quality. The rubber insertions for flanged joints shall be 3 mm. thick. The bolts and nuts of approved make and sizes shall also be supplied by the contractor for making the flanged joints.

All steel required such as M.S. rounds. Angle Iron etc. will be arranged by the contractor himself. The steel used on works shall be of tested quality.

Certain other materials not particularly mentioned or described herein may be required for the works and these if not specifically mentioned shall comply with the description set out in P.W.D. Detailed specification or Indian or British standard specifications for the respective materials. The specification in so far as they are applicable, shall be deemed to be incorporated in the contract, in a manner as given in schedule-E.

WORK & WORKMANSHIP

The tenderer are advised to inspect the sites at which the work is to be carried out so that they may form their own idea regarding the difficulties in transportation of materials and execution of work.

They are also advised to make their own investigations regarding the conditions of underground sub-soil conditions & strata, availability of materials and water required for construction and tests so that they may quote their rates after accounting for all the difficulties and making provisions for the complete items of works. It may be noted by the tenderer that the various items of works included in BOQ required to be executed for construction of water retaining structures have to be executed with all due care so that the water retaining structures remain completely water tight. The contractor shall be responsible for the complete water tightness of the pipe line joints, and reservoirs and other similar water tight structures and he will be required to give a water tightness test for the same at his own cost, in a manner as described at appropriate places, to the satisfactions of the Engineer in charge.

The alignment of various mains to be laid has been clearly shown on the plans which can be seen in the office. The Executive Engineer reserves the right to alter the alignments and to affect similar changes without any compensation what so ever.

The excavation for foundations of buildings and trenches for pipe line shall be carried out in accordance with the P.W.D. detailed specification No. 3 of Part-I section 'A' and L.S.G.E.D./U.P. Jal Nigam, detailed specifications No. 2 & 3. The rate shall include for sheeting, shuttering, timbering, pumping out of water where ever necessary all complete and also sorting out of serviceable materials if any. The contractor shall be responsible for any damage done to adjoining property or to any of the works in progress or partially completed due to any slips, subsidence's etc. He shall make good all damages on this account at his own cost to the satisfaction of Engineer.

The trenches shall be made of sufficient width to provide proper and enough working space. However, he should note that the width of the trenches that shall be payable will be upto a maximum of 0.6 meters plus pipe inner dia. If the contractor excavates a width lesser than this, the actual width excavated will be paid.

The bed of the trenches for laying of pipe line shall be made perfectly level without any projections of stones, boulders etc.

The contractor shall provide gangways for the convenience of pedestrians and occupants of the adjoining property. The closure of roads or diversions of traffic shall not be slowed unless obligatory in the opinion of the Engineer.

Pipes shall be truly laid to the depth and gradient with the aid of rails and boning rod or as may be directed by the Engineer.

Care shall be given to see that all pipes and specials are carefully cleaned before joining is commenced and precautions must be taken to prevent any rubbish or foreign matter finding its way into the pipes while they are being laid. These of all the mains that are laid by him and if called up to do so, shall test each section before it is covered up under pressure equal to a head of 60 meters of water and should any leakage or obstruction found in the pipe before or during the maintenance period he will be required to trace the cause and remove and rectify the same at his own cost.

No damaged pipes and specials shall be lowered in the trenches. Rates will also include the cost of testing of pipe lines. The work shall not be considered as complete till the pipe lines are tested as specified.

The rates for service valve chamber shall be for the complete chamber as per type design. Rate shall include for supply of fixing of R.C.C. pipe. Valves fire hydrants, all are supplied by the contractor. The rates shall include for the supply of all jointing materials e.g. for the supply of rubber insertions, packing, bolts, nuts, washers etc. This item shall also include the laying and jointing of tail pieces with lead and spun yarn. Fixing of sluice valves shall be paid extra over the length of pipe line.

It may be necessary to open these water supply fittings, oil and grease, replace the gland packing etc. The rate shall include for all such works.

When shingles are used in concrete work, then a deduction equal to 7 (seven) percent shall be accounted to work out actual consumption of cement. In case when shingles are used consumes more cement, then after accounting above deduction, then recovery for the extra consumption shall be effected at double rates for the wasteful consumption, as per condition of schedule-I. The contractor should make himself familiar with the actual cement consumption figures for different mixes before carrying any particular work. The theoretical consumption figures, as workout during the progress of work should tally with the consumption figures, of course after accounting the deductions as mentioned above for shingle.

Leaving aside the case when specific written orders exits, the contractor in no case should use extra cement than the norms fixed for particular work which can be had from the respective office on written request. In case if the contractor does consume extra cement then treating it as a wasteful expenditure no payment will be made to contractor for said wasteful expenditure. The contractor's rate shall include for carting the material to site of work and embedding the same in PCC as shown in the drawings. All other chambers shall be constructed as per type design and the item of works involved in construction of the same shall be as per relevant P.W.D. & Jal Nigam detailed specifications.

The cement concrete work shall be carried out as per P.W.D. detailed specifications. No. 30 and 31 of Part-I section 'A' (Buildings). The coarse aggregate shall consisting of approved shingle aggregate or hard stone ballast of 40 mm. gauge for P.C.C. 1:4:8 and 20mm. gauge for P.C.C. 1:2:4. The face stones shall be laid in alternate headers and stretchers. The stones shall break joints on the faces for at least $\frac{1}{2}$ the height of the coarse. The walls and pillars shall be carried up truly plumb and all courses shall be laid truly horizontal. Each stone shall be laid with both bed & vertical joints quite full of mortar. Simple lapping at the edges shall not be permitted. No face joint shall be thicker than 10 mm. The mortar used shall consist of one part of cement and 4 parts of approved of local sand. The joints shall be struck finished at the time of laying. The rate shall include for supply of all materials, scaffoldings, labour, tools and plants, etc. required for proper completion of the work.

The work shall be carried out in accordance with P.W.D. detailed specifications No. 35 of Part-I section 'A' (Buildings) in general. The rate shall include for rendering smooth of all exposed surface after removal forms and centering which shall be neat and properly smooth ened planks. No extra payment for the rendering plastering of surface of RCC shall be made.

The moulds and centering of concrete shall be substantially and rigidly constructed true to shape and dimensions shown in drawings. The rate shall include for cleaning of mild steel bars of all rust, dust etc., their fixing in position, and binding the same, with 24 BMG wire.

For all R.C.C. works, stone grit 10 mm. to 12 mm. gauge or as specified in the BOQ and clean coarse sand will be used. The mix shall be in the proportion as given in the description of items or drawings.

The work shall be carried out in accordance with PWD detailed specifications No. 35 & 89 of Part-I section 'A' (Buildings). The rate of M.S. reinforcement for R.C.C. work shall include for cleaning of mild steel bars of grease, dust etc., cutting to the same and fabrication to required shape and size. The reinforcement shall be measured for end to end and no extra payment shall be made for hook, band, over lapping and wastage. The bars shall be bent cold. The over lapping shall be to a length not less than 45 times the diameters of the bars and all bars shall be hooked at each end.

All steel used in the different works shall be of tested quality and will be arranged by the contractor himself. The contractor shall furnish the test certification of the steel brought by him to the site in demand and will also bear the charges for the testing of steel brought to the site if desired by the Engineer. It shall be free from pitting, loose, rust or mild scales, oil or grease, adhering earth or other materials that may adhere the bond between the concrete and the steel.

The work shall be carried out as per P.W.D. detailed specifications Part-I section 'A' (Buildings) and as per conditions given in reference books/booklets under schedule. Only first class bricks confirming various specified test (s) should be used.

The rate shall include for the supply of C.I. fittings and appurtenances of approved quality and make at site of work and fixing the same as per direction of the Engineer-in-charge all complete, as per conditions of the contracts.

There may be certain other items of work which though not specifically mentioned or described here in above may be required to be executed for the due completion of the work under this contract. All such works shall be carried out as per relevant Jal Nigam or P.W.D. detailed specifications of Part-I and II and these specifications shall be deemed to have incorporated in this contract, read along with other clauses applicable under this contractor.

Best quality paint or varnish for each class of work shall be used and the work shall be carried out according to P.W.D. detailed specification No. 69 & 70 part-I section 'A' (Buildings). The color and make shall be approved by Engineer-in-charge.

The contractor is advised quote their rates after working out their own quantities of work required to be done and quote their rates accordingly. The rates shall include for the supply and fixing of G.I. pipes specials of approved quality as per BIS specification. The rate shall also include for painting the exposed pipe.

Maxfalt will be filled in mid between R.C.C. roof mixed with coarse sand and saw dust after making the expansion joints by cutting the edges of slabs. The work shall comply with P.W.D. detailed specifications. White washing or color washing shall comply with P.W.D. detailed specification no. 74 Part-I Schedule 'A' (Buildings) and as described in BOQ. The color shall be getting approved first from Engineer-in-charge.

This work shall be complying with Jal Nigam and P.W.D. detailed specifications and specified in BOQ to the satisfaction of Engineer I/C.

Semicircular P.C.C. drain shall be constructed as per type design. All the item of work in valued in construction shall be carried out as per P.W.D. detailed specification. The interior of drain shall be perfectly smooth with neat cement and shall be truly semi circular.

Earthwork and Excavation

RELEVANT IS CODES

IS: 1200	:	Method of Measurement for Building Works
IS: 3764	:	Safety code for Excavation Work
IS: 3385	:	Code of practice for measurement of civil engineering works
IS: 2720	:	Part II - Determination of Moisture Content
	:	Part VII - Determination of Moisture content dry density relation using light compaction
	:	Part VIII - Determination of Moisture Content Dry Density using heavy compaction
	:	Part XXVIII - Determination of Dry Density of soils, in place, by the sand replacement method
	:	Part XXIX - Determination of Dry Density of soils, in place, by the core cutter method.

EXCAVATION

Definitions

The following terms shall have the meanings hereby assigned to them:

Top Soil means any surface material, including turf, suitable for use in soiling areas to be grassed or cultivated.

Excavation means excavation in open cut (excluding trench excavation) down to levels required as per approved Drawings or otherwise as being the general levels after completion of excavation.

Site Clearance

All area of the Site, marked in the Specification / Drawings shall be cleared to the extent required by the Engineer-in-Charge of all buildings, walls, gates, fence and other structure and obstructions of all bushes, hedges, trees, stumps, roots and other vegetation except for trees marked for preservation. Material so cleared shall so far as suitable be preserved and stacked will be the property instructed by the Engineer-in-Charge.

Before starting the work the site shall be cleared of all shrubs, grass, and other vegetation including large and small bushes, all stumps, removal of roots, cutting and disposal of small trees up to 300 mm girth etc.

All the trees having girth above 300 mm. (the girth shall be measured at a height of 1.5 m above the ground level) by felling, logging, fashioning of timber and billeting of all branches, trunks etc. including removal of all roots etc. complete as directed.

All serviceable reclaimed material shall be stacked separately at the site shown by the Engineer In Charge near the site of excavation and/or transported as directed by Engineer In Charge

After the tree is cut and roots taken out, the potholes formed shall be filled with good earth in 250mm layers and consolidated unless directed by the Engineer in Charge otherwise. The trees shall be cut in suitable piece as instructed by the Engineer In Charge

General Excavation

General excavation means excavation required for structures and from borrows areas, and shall not include trench excavation. General excavation may also include miscellaneous isolated lengths of trenches beneath or adjacent to other structures, trial pits along the structural layout or otherwise.

The ground shall be excavated by such methods and to such dimensions and depths as shall allow for the proper construction of the works and safety of personnel and equipment used on excavation. Slopes required for stable formation of sides shall be provided.

The excavation in earth, murum, boulders, soft and hard rock shall be carried out to the correct levels required and specified and no tolerance, plus or minus, shall be permitted. However, if any depressions/Loose pockets are formed due to removal of boulders, they shall be made good by filling with 1:5:10 concrete up to the bottom layer of the footing/raft. Payment for all types of excavation shall be made by detailed measurement supported by ground levels recorded prior to and after completion of excavation, subject to the limit for payment indicated by the slopes of excavation indicated in the specification drawing. Any additional excavation will be at the contractor's expense, unless specifically approved by the Engineer-in-Charge. Measurement for excavation shall be done all as per dimensions of P.C.C. given in design drawings & specifications. For concrete foundations same shall be paid on least dimensions at bottom and contractor shall cover any extra excavation required for workspace, supports etc while quoting.

As far as possible excavation should be done by means of mechanical equipment. The bidder should quote accordingly and nothing extra will be paid for mechanical excavation and deployment of extra staff.

It will be the responsibility of the contractor to obtain prior permissions from the competent authority to use blasting device, if at all to be resorted to and the license are to be obtained for the same.

The chance of blasting required shall be well decided with the expert, to avoid any damage to the surrounding property. However for any such damage to the surrounding property or public or additional excavation shall be the contractor's responsibility and the risks what so ever arising from the same will have to be borne by the contractor.

Lead

Lead for deposition of the excavated materials should be at appropriate places. For the purpose of measurement of lead, the area to be excavated or filled or area in which excavated material is to be deposited /disposed off shall be divided into suitable blocks and for each of the blocks, the distance between centerlines shall be taken as the lead which shall be measured by the shortest straight line route on plan and not the actual route taken by contractor. No extra compensation is admissible on the grounds that the lead including that for borrowed material had to be transported over marshy or kaccha land route.

Excavation in Hard Rock

Excavation in hard rock may be done either by blasting or chiseling depending upon the site conditions. When excavation has reached within 300 mm of the required formation level, further excavation shall be carried out carefully either by blasting (if as directed by the Engineer-in-Charge) or chiseling. Where blasting is resorted to, small charges shall be used to minimize occurrence of heavy over-cuts. The Contractor shall make every effort to carry out the excavation to correct formation level as far as practicable. In order to minimize the over break and loosening of materials at the finished surfaces, final cutting for the last 450 mm to 600 mm in rock shall be carried out by controlled blasting and trimming with the help of pneumatic or other power tools. Unless otherwise specified, the over break shall not exceed 75 mm. The over breakage of 75 mm shall not be measured for payment and therefore the Contractor while quoting his rates for rock excavation has to take this into account. Deduction of 40% or higher percentage as may be decided by the engineer-in-

Charge shall be made to allow for the voids. Stacks shall not be of width greater than 1.5 m wide or of height less than one meter

Blasting shall be carried out by the licensed person The contractor shall provide a method statement and shall comply fully with the requirements of this clause, or any direction, order, requirement or instruction given by the police department or any other relevant authorities as required by the law.

Contractor shall submit Blasting plan to the ENGINEER-IN-CHARGE and take approval for the same on daily basis

Contractor shall plan the blasting activities in well advance and convey same to the Engineer In-charge so as to co-ordinate with all the work groups at site.

This includes rock, which is easily excavated by blasting, but due to close proximity of structures or any other reason that the Engineer-in-Charge may consider, will have to be excavated by chiseling.

It should be noted that this clause does not override the contractor's obligation to satisfy the requirement of the relevant authorities but sets out the extent to which the Engineer in charge will exercise his control in approving the contractor's use of explosive to ensure that explosive are always used in a safe manner. It is the contractor's sole responsibility to ensure that his method of blasting is safe, that all statutory and imposed limitation are adhered to, and to obtain a permit to use explosive from the relevant authorities and to comply with the condition of issue of the permit.

The contractor shall be solely responsible for obtaining the necessary licenses for the procurement, possession, transport, storage and handling of explosive and for ensuring the validity of such licenses at all times. Before starting work, the contractor shall satisfy the Engineer that all the requirement permits are in order and that this category of work is adequately covered in the policies of insurance.

Explosives shall be used in the quantities and manner recommended by the manufacturers.

All necessary precautions shall be taken to preserve the materials below in the soundest possible condition and also beyond the lines of all excavations.

Blasting by means of drill holes, tunnels or any other similar method shall be the responsibility of the contractor.

The contractor shall take all necessary precautions during blasting operations to ensure that no injure is caused to persons or damage to property or to the finished works. Shots shall be properly loaded and capped and only appropriate charges shall be used in each hole.

Storage and Transport

Proper building or magazine, with separate compartment for detonators in suitable positions for the storage of explosive in the manner and quantities to be approved, shall be provided. Separate vehicles or vessels for detonators shall also be used for the transportation of explosives. The prevention of any unauthorized issue or improper use of any explosive brought on to the site shall be the responsibility of the contractor and only experienced licensed short firers shall be employed to handle the explosive for the purpose of the work the relevant security regulations dealing with the storage, handling and transport of explosives shall be complied with.

Safety

The Contractor shall provide an approved system of warning and preparing the general public and all site personnel of an impending blast by both audible & visual means and shall ensure that the blasting area is cleared of all personnel immediately prior to blasting. This system shall comply with all statutory requirements. The contractor's attention is drawn to the need to devise adequate system for warning and clearing the public from specified areas during blasting operations and to prevent persons entering the blasting area.

When blasting is near to the proximity of existing public and private thoroughfares, traffic is to be stopped just prior to firing. The operation is to be carried out in close cooperation with the police department and in such a way as to cause minimum traffic delay.

All operations involving explosives shall be suspended on the approach of a thunderstorm and shall not be resumed until the storm has clearly passed.

Blasting screens shall be erected to conform with the permit conditions. Public roads, private roads and property adjacent to the site and services within the site area shall be protected by rock fall fences which will be subjected to the engineer's approval.

The contractor shall take all necessary precautions to avoid damage to permanent and temporary works already completed. In all cases, delay blasting techniques will be mandatory with the quantity of explosives restricted to ensure that the peak particle velocity generated does not exceed the peak particle velocity of each component of the safe limits of the nearest structure subject to vibration damage. All operations shall stop when these limits are exceeded until reports are made available to the engineer that no damage has occurred and will not occur or corrective action has been taken to lower the vibration. The sound level limit in areas where site personnel or public can access during blasting operation must not exceed 110 dB.

The contractor may not be permitted to use explosives in areas of the site immediately adjacent to pylon positions. Particular limitations may apply in such areas depending on the contractor's proposed method of working and a detailed method statement will therefore be required from the contractor. The method statement shall cover the methods of excavation and protection systems proposed, all of which shall be subjected to the approval of the relevant authorities and the Engineer.

In all such cases particular attention should be paid to the requirements stated above and effects on these structures and installations shall be closely monitored and the quantities of explosives limited accordingly.

Drilling rigs for shot hole shall be of the hydraulic type fitted with efficient silencers and with means of dust separation.

The Contractor may report to any of the following methods to excavate rock by chiseling:

Wedging by means of crowbars, pick axes or pneumatic drills

Heating and quenching

Controlled blasting with a small charge just sufficient to make a crack in rock which will be subsequently removed by wedging

No extra payment shall be made for removal of rock by chiseling and controlled blasting.

Excess excavation to be made good

The contractor, at his own expense, shall, if directed, remove from the Site all excess material resulting from excess excavation and shall make good the same with such kind of fill material or in such class of concrete as may be reasonably required by the Engineer-in-Charge having regard to the circumstances.

Stripping Top Soil

Where ordered by the Engineer-in-Charge, top soil shall be stripped to such depths and over such areas as he may direct, as a separate operation prior to any further excavation, which may be required.

Supporting Excavations

The Contractor shall properly support the sides and ends of all excavations to prevent any fall or run from any portion of the ground outside the excavation and to prevent settlement or damage to structures adjacent to the excavation. Any excavation necessary to provide space for such support or other working space shall be carried out. If, for any reason, any portion of the bottoms, sides or ends of any excavations shall give way, the contractor shall at his own expense take all necessary remedial measures including the extra necessary excavation and removal of excess material.

Where the Contractor proposes and is permitted by the Engineer-in-Charge to perform excavations with sloping faces (other than sloping excavations shown on the Drawings or required as permanent features of the Works) and without shoring, the excavated faces shall be to stable slopes and heights.

Trimming Excavations

When excavating to specified or required levels for the foundation of any structure or to specified or required limits for the face of any structure required to abut undisturbed ground, the Contractor shall not excavate the last 150 mm until immediately before commencing the constructional work, except where the Engineer-in-Charge shall permit otherwise. After getting the permission for the commencement of the construction, if the contractor delays on any account & the formation level gets damaged he will have to do further excavation upto 150mm or as per Engineer-in-charge's instructions at his own account.

Before commencement of any constructional work all shattered and loose materials shall be removed from the excavations by hand so as to ensure that the work rests on a solid and perfectly clean foundation or abuts against solid ground.

Inspection by the Engineer-in-Charge

When the specified levels or limits of excavation are reached the Engineer-in-Charge will inspect the ground exposed, and if he considers that any part of the ground is by its nature unsuitable he may direct the Contractor to excavate further. Such further excavation shall be refilled to the specified levels or limits with concrete, selected excavated material or selected imported material as directed by the Engineer-in-Charge.

Should the material forming the bottom of any excavation, while acceptable to the Engineer-in-charge at the time of his inspection, subsequently become unacceptable to him due to exposure to weather conditions or due to flooding or have puddles, soft or loss during the progress of the works, the Contractor shall remove such damaged, softened or loosened material and excavate without any extra cost.

Disposing Excavated Material

All excavated material shall remain the property of the Employer. The Contractor shall ensure that no excavated material which is suitable for and is required for re-use in the Works is transported unless so ordered by the Engineer-in-Charge.

Back-Filling General Site Grading And Sand Filling

Fill Material

All fill material whether such material is brought from outside borrow areas or excavation within the site, will be subject to Engineer-in-Charge's approval after carrying required tests at Contractor's Soil testing laboratory. Notwithstanding any approval given to the fill material or borrow areas from which fill material is proposed to be brought, the Engineer-in-Charge reserves the right to reject such material which does not meet the specification requirements or unsuitable for the purpose for which it is intended.

Backfilling

Excavated material used as back filling to excavations or completed structures shall be free from rubbish, vegetation, clods and lumps and shall be approved by the Engineer-in-charge. The approved materials shall be placed in layers, not exceeding 150 mm in depth before compaction and shall be compacted with watering, consolidating and ramming. The maximum boulder size shall be of 150 mm for filling material

Soft material shall not be used as back filling around structures in rock. The Contractor shall backfill such excess excavation with concrete; rubble, stone or rock fills as directed by the Engineer-in-Charge. Filling other than concrete shall be placed in layers not exceeding 150 mm in thickness, shall be thoroughly compacted and have adequate fined content to fill the voids.

Should the material being placed as back filling, while acceptable at time of selection, become unacceptable to the Engineer-in-Charge due to exposure to weather conditions or due to flooding or have become puddles, soft or segregated during the progress of the works, the Contractor shall remove such damaged, softened or segregated material and replace it with fresh approved material at his expense.

The Contractor shall while placing the back filling make due allowance for any settlement that may occur before the end of the Defects Liability Period, remove any excess material or make up any deficiency by back filling to the specified levels. As a rule material to be back filled shall be stacked temporarily at a suitable place.

General Site Grading: Site grading shall be carried out as directed by the Engineer-in-Charge. Excavation shall be carried out as specified in the specification. Filling and compaction shall be carried out as specified under (6) of this Clause unless otherwise indicated below.

The approved material shall be placed in layers not exceeding 150 mm in depth before compaction and shall be compacted to 90% of Proctor Density with water contain at OMC.

The Contractor shall protect the earth fill from being washed away by rain or damaged in any other way. Should any slip occur, the Contractor shall remove the affected materials and make good the slip without any extra cost.

The fill shall be carried out to such dimensions and levels as directed by the Engineer-in-charge, after the compaction.

Sand filling below Plinth and other places

Back filling shall be carried out with sand at places as directed by the Engineer-in-Charge. The sand used shall be clean, medium grained and free from impurities. The filled-in-sand shall be kept flooded with water for 24 hours to ensure maximum consolidation. Any temporary work required to contain sand under flooded conditions shall be to the Contractor's account. The surface of the Consolidated sand shall be dressed to the required

level or slope. Construction of floors or other structures on sand fill shall not be started until the Engineer-in-Charge has inspected and approved the fill.

Where specified in the schedule of works, compaction of the plinth fill shall be carried out by means of 12 tone rollers smooth wheeled, sheep foot or wobbly wheeled rollers. A smaller weight roller may be used only if permitted by Engineer-in-Charge. As rolling proceeds water sprinkling shall be done to assist consolidation. Water shall not be sprinkled in case of sandy fill.

The thickness of each unconsolidated fill layer can in this case upto 300 mm. Engineer-in-Charge will determine the thickness of layers in which fill has to be consolidated depending on the fill material and equipment used.

Rolling shall commence from outer edge and progress towards the centre and continue until compaction is to the satisfaction of the Engineer-in-charge, but in no case less than 10 passes of the roller will be accepted for each layer.

The compacted surface shall be properly shaped, trimmed and consolidated to an even and uniform gradient. All soft spots shall be excavated and filled and consolidated.

At some locations / areas it may not be possible to use rollers because of space restrictions etc. Contractor shall then be permitted to use pneumatic tampers, rammers etc and he shall ensure proper compaction.

Fill Density

The compaction, only where so called for, in the schedule of quantities /items shall comply with the specified (proctor/modified proctor) density at moisture content differing not more than 4 percent from optimum moisture content. Contractor shall demonstrate adequately at his cost, by field and laboratory tests that the specified density had been obtained.

Local Rules And Regulations

The Contractor shall familiarize himself with the local rules and regulations governing the excavation, quarrying operations, etc. and the work shall be carried out strictly in accordance with rules and regulations, if any. Whenever a quarry is required to be opened in connection with the execution of work covered under this Contract, the Contractor shall investigate that it shall yield stones and other materials such as sand, murum, soil etc. of approved quality and shall satisfy himself as to the availability in desired quantity. He shall supply necessary quantity of sand, stone, metal aggregate etc. to the Engineer-in-Charge for carrying out tests as desired by the Engineer-in-Charge and well in advance of its use so as to carry out tests and to get approval. The cost of opening and operating the quarry & royalties and ant other charges shall be borne entirely by the Contractor.

The Contractor shall obtain necessary permission from the concerned authorities before opening the quarry. In case of quarries in private land on payment of whatever charges as may be due to the owner.

DEWATERING

All excavations shall be kept free of water. Grading in the vicinity of excavations shall be controlled to prevent surface water running into excavated areas. The Contractor shall remove by pumping or other means approved by Engineer-in-Charge any water inclusive of rain water and sub-soil water accumulated in excavation and keep all excavations de-watered until the foundation work is completed and back filled. Sumps made for

dewatering must be kept clear of the excavations/trenches required for further work. Method of pumping shall be approved by Engineer-in-Charge; but in any case, the pumping arrangement shall be such that there shall be no movement of sub-soil or blowing in due to differential head of water during pumping. Pumping arrangements shall be adequate to ensure no delays in construction.

When there is a continuous inflow of water and quantum of water to be handled is considered in the opinion of Engineer-in-Charge, as large, well point system: Single-stage or Multi-stage shall be adopted. Contractor shall submit to the Engineer-in-Charge his scheme of well pointing system including stages, the spacing, number and diameter of well points, headers etc. and the number, capacity and location of pumps for approval.

The rates for excavation are inclusive of dewatering by any means and no extra payment is allowed for excavation in wet condition.

TIMBER SHORING

The Timber Shoring shall be as per 3764-1966 safety code for excavation work.

Close timbering shall be done by completely covering the sides of the trenches and pits generally with short, upright members called 'polling boards'. The boards shall generally be placed in position vertically side by side without any gap on each side of the Excavation and shall be secured by horizontal walings of strong wood at maximum 1.2 m spacing and suitably strutted. If the soil is very soft and loose, the boards shall be placed horizontally against each side of the excavation and supported by vertical walings, which in turn shall be suitably strutted. The lowest boards supporting the sides shall be taken into the ground and no portion of the vertical side of the trench or pit shall remain exposed, so as to render the earth liable to slip out.

The shoring material shall not be sizes less than those specified below unless steel sheet piling is used or unless otherwise approved by the Engineer-in-charge in writing:

Planks	-	5 cm x 25 cm
Waling pieces	-	10 cm x 20 cm
Struts	-	15 cm x 20 cm

Timber shoring shall be 'close' or 'open' type, depending on the nature of soil and the depth of pit or trench. The type of timbering shall be as approved by Engineer-in-charge. It shall be the responsibility of the Contractor to take all necessary steps to prevent the sides of excavations, trenches, pits, etc., from collapsing.

Timber shoring may be required to keep the sides of excavations vertical to ensure safety of adjoining structures or to limit the slope of excavations, or due to space restrictions or for other reasons. Such shoring shall be carried out, except in an emergency, only under instructions from the Engineer-in-Charge.

The withdrawal of the timber shall be done very carefully to prevent the collapse of the pit or trench. It shall be started at one end and proceeded systematically to the other end. Concrete or masonry shall not be damaged during the removal of the timber. No claim shall be entertained for any timber, which can not be retrieved.

In the case of open timbering, the entire surface of the side of trench or pit is not required to be covered. The vertical boards of minimum 25 cm X 5 cm sections shall be spaced sufficiently apart to leave unsupported strips of maximum 50 cm average width. The detailed arrangement, sizes of the timber and the spacing shall be subject to the approval of the Engineer-in-Charge. In all other respects, the specification for close timbering shall apply to open timbering.

In case of large pits and open excavations, where shoring is required for securing safety of adjoining structures or for any other reasons and where the planking across sides of excavations/pits cannot be strutted against, suitable inclined struts supported on the excavated bed shall be provided. Load from such struts shall be suitably distributed on the bed to ensure no yielding of the strut.

RAIN WATER DISCHARGE

Scope

The scope covers the drainage of the rainwater in excavated areas.

Grading in the vicinity of excavation shall be such as to exclude rain/surface water draining into excavated areas. Excavation shall be kept clean of rain and such water as the Contractor may be using for his work by suitably pumping out the same at no extra cost to the Owner. The scheme for pumping and discharge of such water shall be approved by the Engineer-in-Charge.

Anti Termite Treatment

IS: 6313 – 1981	:	Code of Practice for Anti Termite Measure in Buildings
IS: 6313 (Part I) – 1981	:	Construction Measures
IS: 6313 (Part II) – 1981	:	Pre-Construction Chemical Treatment Measures
IS: 6313 (Part III) – 1981	:	Treatment for existing Buildings

Delivery, Storage and Handling

Deliver pesticides to the project site in sealed and labeled containers in good condition as supplied by the manufacturer or formulator. Store, handle, and use pesticides in accordance with manufacturer's labels. Labels shall bear evidence of registration as per the IS or appropriate regulations.

Safety Requirements

Formulate, treat, and dispose of termiticides and their containers in accordance with label directions. Draw water for formulating only from sites designated by the Contracting Officer, and fit the filling hose with a backflow preventer meeting local plumbing codes or standards. The filling operation shall be under the direct and continuous observation of a contractor's representative to prevent overflow. Secure pesticides and related materials under lock and key when unattended. Ensure that proper protective clothing and equipment are worn and used during all phases of termiticide application. Dispose of used pesticide containers off Government property

Warranty

Furnish an three-year written warranty against infestations or reinfestations by subterranean termites of the buildings or building additions constructed under this contract. Perform annual inspections of the building(s) or building addition(s). If live subterranean termite infestation of subterranean termite damage is discovered during the warranty period, and the soil and building conditions have not been altered in the interim, the Engineer-in-charge :

- Retreat the soil and perform other treatment as may be necessary for elimination of subterranean termite infestation;
- Repair damage caused by termite infestation; and
- Reinspect the building approximately 180 days after the pretreatment.

Quality Assurance

Application Report

Upon completion of this work, submit Pest Management Report, Identifying target pest, type of operation, brand name and manufacturer of pesticide, formulation, concentration or rate of application used. Maintain daily records using Pest Management Maintenance Record, and submit copies of records when requested by the Engineer-in-Charge.

PRODUCTS

Pesticides

Termiticides bearing current registration or approved for such use by the appropriate agency of the host country. The Contractor shall comply with the requirements on contractor's licensing, certification, and record keeping.

Execution

Verification of Conditions

At the time of application, the soil shall have sufficiently low moisture content to allow uniform distribution of the treatment solution throughout the soil. Do not make applications during or immediately following heavy rains or when conditions may cause runoff and create an environmental hazard.

Application

Treatment Area

Apply termiticide to soil material which will be covered by or lie immediately adjacent to the buildings and structures so as to provide a protective barrier against subterranean termites.

Treatment Application

Apply termiticide as a coarse spray and in such matter as to provide uniform distribution onto the soil surface. Apply treatment prior to placement of a vapor barrier or waterproof membrane and prior to concrete pouring. Where treated soil or fill material is not to be covered with a vapor barrier or waterproof membrane, exercise adequate precautions to prevent its disturbance. If soil or fill material has been disturbed after treatment, retreat as specified above before placement of slabs or other covering structures. Coordinate treatment of the soil on the exterior sides of foundation walls, grade beams, and similar structures with final grading and planting operations so as to avoid disturbance of the treated barriers by such operations. Observe manufacturer's warnings and precautions in the handling and use of such materials. Exercise precaution that these chemicals do not enter water supply systems or potable water supplies or aquifers, and that they do not endanger plants and animals as well. Notify the Contracting Officer at least 48 hours prior to beginning of treatment and perform formulating, mixing, and application in the presence of the Employer's representative.

Rates and Methods of Application

Apply in accordance with the pesticide label. Provide maximum application or dosage rates. Resolve conflict between this specification and label direction in favor of the label.

Concrete And Allied Works

GENERAL

The quality of materials and method and control of manufacture and transportation of all concrete work irrespective of mix, whether reinforced or otherwise shall conform to the applicable portions of this specification.

The Engineer-in-Charge shall have the right to inspect the source/s of material/s, the layout and operation of procurement and storage of materials, the concrete batching and mixing equipment, and the quality control system. Such an inspection shall be arranged and Engineer-in-Charge's approval obtained, prior to starting of concrete work. However, this shall not relieve the contractor with any of his responsibilities and all the materials, which do not conform to the specifications, will be rejected.

The minimum wall thickness for all RCC wall shall be 225 mm thick.

The liquid retaining structures will be in M30 grade.

The Contractor will maintain all registers and formats for quantity qualitative and quantitative measures of all concrete works on daily basis of steel consumed and concreting done updated on daily basis.

APPLICABLE CODES

The following specifications, standards and codes, including all official amendments/revisions and other specifications & codes referred to therein to therein, should be considered a part of this specification. In all cases the latest issue/edition/revision shall apply. In case of discrepancy between this specification and those referred to herein this bid document, this specification shall govern.

MATERIALS

- IS:29 - Specification for 33 grade ordinary Portland cement
- IS:455 - Specification for Portland slag cement.
- IS:148 - Specification for Portland-pozzolana cement.
- IS: 811- Specification for 43-grade ordinary Portland cement.
- IS: 123- Specification for sulphate resisting Portland cement.
- IS: 383- Specification for coarse and fine aggregates from natural sources for concrete.
- IS: 432 - Specification for mild steel and medium tensile steel (Parts-I & II) bars and hard-drawn steel wires for concrete reinforcement.
- IS: 1786- Specification for high strength deformed steel bars and wires for concrete reinforcement.
- IS: 1566- Specification for hard-drawn steel wire fabric for (Part-I) concrete reinforcement.
- IS: 9103- Specification for admixtures for concrete.
- IS: 2645- Specification for integral cement waterproofing compounds.
- IS: 4990- Specification for plywood for concrete shuttering work.

MATERIAL TESTING

- IS: 4021 - Methods of physical tests for hydraulic cement. (Parts-1 to 13)
- IS: 4032 - Method of chemical analysis of hydraulic cement.
- IS: 650 - Specification for standard sand for testing of cement.
- IS: 2430 - Methods for sampling of aggregates for concrete.
- IS: 2386 - Methods of test for aggregates for concrete. (parts-I to VIII)

- IS: 3025 - Methods of sampling and test (physical and chemical) water used in industry.
- IS: 6925 - Methods of test for determination of water-soluble chlorides in concrete admixtures.

MATERIALS STORAGE

- IS: 4082 - Recommendations on stacking and storing of construction materials at site.

CONCRETE MIX DESIGN

- IS: 10262 - Recommended guidelines for concrete mix design.
- SP: 23 - Handbook on Concrete Mixes. (S & T)

CONCRETE TESTING

- IS: 1199 - Method of sampling and analysis of concrete.
- IS:516 - Method of test for strength of concrete
- IS: 9013 - Method of making, curing and determining compressive strength of accelerated cured concrete test specimens.
- IS: 8142 - Method of test for determining setting time of concrete by penetration resistance.
- IS: 9284 - Method of test for abrasion resistance of concrete.
- IS: 2770 - Methods of testing bond in reinforced concrete.

EQUIPMENT

- IS: 1791 - Specification for batch type concrete mixers.
- IS: 2438 - Specification for roller pan mixer.
- IS: 4925 - Specification for concrete batching and mixing plant.
- IS: 5892 - Specification for concrete transit mixer and agitator.
- IS: 7242 - Specification for concrete spreaders.
- IS: 2505 - General Requirements for concrete vibrators: Immersion type.
- IS: 2506 - General Requirements for screed board concrete vibrators.
- IS: 2514 - Specification for concrete vibrating tables.
- IS: 3366 - Specification for pan vibrators.
- IS: 4656 - Specification for form vibrators for concrete.
- IS: 11993 - Code of practice for use of screed board concrete vibrators.
- IS: 7251 - Specification for concrete finishers.
- IS: 2722 - Specification for portable swing weigh batchers for concrete (single and double bucket type).
- IS: 2750 - Specification for steel scaffoldings.

CODES OF PRACTICE

- IS: 456 - Code of practice for plain and reinforced concrete.
- IS: 457 - Code of practice for general construction of plain and reinforced concrete for dams and other massive structures.
- IS:3370 - Code of practice for concrete structures for storage of liquids.(parts-I to IV)

- IS: 3935 - Code of practice for composite construction.
- IS: 2204 - Code of practice for construction of reinforced concrete shell roof.
- IS: 2210 - Criteria for the design of reinforced concrete shell structures and folded plates.
- IS: 2502 - Code of practice for bending and fixing of bars for concrete reinforcement.
- IS: 5525 - Recommendation for detailing of reinforcement in reinforced concrete works.
- IS: 2751 - Code of practice for welding of mild steel plain and deformed bars used for reinforced concrete construction.
- IS: 9417 - Specification for welding cold worked bars for reinforced concrete construction.
- IS: 3558 - Code of practice for use of immersion vibrators for consolidating concrete.
- IS: 3414 - Code of practice for design and installation of joints in building.
- IS: 4326 - Code of practice for earthquake resistant construction of building.
- IS:4014 - Code of practice for steel tubular scaffolding.(parts-I & II)
- IS: 2571 - Code of practice for laying in-situ cement concrete flooring.
- IS: 7861 - Code of practice for extreme weather concreting.
Part-I: Recommended practice for hot weather concreting.
Part-II: Recommended practice for cold weather concreting.
- IS: 13920 - Ductile Detailing of Reinforced Concrete Structure subjected to 1993 seismic forces.
- SP-16 - Design Aids for Reinforcement Concrete to IS:456-1978 (S&T) - 1980
- SP-24 - Explanatory Handbook on IS: 456-1978
- SP-34 - Handbook on Concrete Reinforcement and Detailing(S&T) - 1987

CONSTRUCTION SAFETY

- IS:3696 - Safety code for scaffolds and ladders.(Parts-I & II)
- IS:7969 - Safety code for handling and storage of building materials
- IS: 8989 - Safety code for erection of concrete framed structures.

MEASUREMENT

- IS: 1200 - Method of measurement of building and engineering works.
- IS: 3385 - Code of practice for measurement of civil engineering works.

MATERIALS FOR STANDARD CONCRETE

The ingredients to be used in the manufacture of concrete shall consist solely of Ordinary Portland Cement or Sulphate Resistant Cement clean sand, natural coarse aggregate, clean water, and admixtures.

The contractor will have to make own arrangements for procuring cement and steel. Cement remaining in bulk storage at the mill, prior to shipment for more than 6 months or cement in bags in local storage in the hands of vendor for more than 3 months after completion of tests may be retested before use and may be rejected if it fails to conform to any of the requirement of IS 269-1976.

The Contractor will have to make his own arrangements for transport from supplier godown and storage of adequate quantity of cement. Contractor will construct cement godown. in

batches of 10x10, which will provide complete protection from dampness, contamination and minimize caking and false set. Cement bags shall be stored in a dry enclosed shed (storage under tarpaulins will not be permitted), well away from the outer walls and insulated from the floor to avoid contact with moisture from the ground and so arranged as to provide ready access. Damaged or reclaimed or partly set cement will not be permitted to be used and shall be removed from the site. The storage bins and storage arrangement shall be approved by the Engineer-in-Charge. Consignments of cement shall be stored as received and shall be consumed in the order of their delivery. Stacking of cement shall be done as per IS and in such a way that first come cement shall be used first.

Cement held in storage for a period of ninety (90) days or longer shall be tested. Should at any time the Engineer-in-Charge have reasons to consider that any cement is defective, then irrespective of its origin, date of manufacture and or manufacturer's test certificate, such cement shall be tested immediately at the Contractor's cost at an approved laboratory and until the results of such tests are found satisfactory, it shall not be used in any work. Testing certificates for each batch of cement should be submitted by the contractor to the Engineer-in-Charge, before starting the concreting work. The Contractor shall not be entitled to any claim of any nature on this account.

Aggregates

i) General

"Aggregate" in general designates both fine and coarse inert materials used in the manufacture of concrete (Vide BIS 456 & BIS 383) and conforming to tests as per BIS 2386 (Part I to VI)

"Coarse Aggregate" is aggregate most of which is retained when passed through on 4.75 mm BIS sieve.

Aggregates shall consist of natural sands, stone (crushed or uncrushed) and gravel from a source known to produce satisfactory aggregate for concrete and shall be chemically inert, non-flaky, strong, hard, durable against weathering, of limited porosity and free from deleterious materials that may cause corrosion of the reinforcement or may impair the strength and or durability of concrete. The grading of aggregates shall be such as to produce a dense concrete of specified strength and consistency that will work readily into position without segregation and shall be based on the "mix design" and preliminary tests on concrete specified later.

ii) Storage of aggregates

All coarse and fine aggregates shall be stacked separately in stock piles in the material yard near the work site in bins properly constructed to avoid inter mixing of different aggregates. Contamination with foreign material and earth during storage and while heaping the materials shall be avoided. The aggregates must be of specified quality not only at the time of receiving at site but more so at the time of loading into mixer. Rakers shall be piled in layers not exceeding 1.20 m in height to prevent coning or segregation. Each layer shall cover the entire area of stockpile before succeeding layers are started. Aggregates that have become segregated shall be rejected.

iii) Specific Gravity

Aggregates having a specific gravity below 2.4 (saturated surface dry basis) shall not be used.

FINE AGGREGATE

Fine aggregate shall consist of natural or crushed sand conforming to BIS 383 confirming to tests as per BIS 2386 part I to VI. The sand shall be clean, sharp, hard, strong and durable and shall be free from dust, vegetable substances, adherent coating, clay, alkali, organic matter, mica, salt, or other deleterious substances, which can be injurious to the setting qualities/strength/durability of concrete.

Screening and Washing: Sand shall be prepared for use by such screening or washing, or both, as necessary, to remove all objectionable foreign matter while separating the sand grains to the required size fraction.

Foreign Material limitations: The percentage deleterious substances in sand delivered to the mixer shall not exceed the following:

Table 2: Foreign Material Limitations in Fine Aggregate

Sr. No.	Foreign material	Percentage by weight	
		Uncrushed	Crushed
1	Material finer than 75 micron BIS sieve	3.0	15.0
2	Shale	1.0	-
3	Coal & Lignite	1.0	1.0
4	Clay Lumps	-	1.0
	Total	5.0	17.0

- d) Gradation: Unless otherwise directed or approved by the Engineer-in-Charge, the grading of sand shall be within the limits indicated hereunder:

Table 3: Grading of Sand for Fine Aggregate

BIS :Sieve Designation	Grading Zone I	Grading Zone II	Grading Zone III	Grading Zone IV
10 mm	100	100	100	100
4.75 mm	99-100	90-100	90-100	95-100
2.36 mm	60-95	75-100	85-100	95-100
1.18 mm	30-70	55-90	75-100	90-100
600 microns	15-34	35-59	60-79	80-100
300 microns	5-20	8-30	12-40	15-50
150 microns	0-10	0-10	0-10	0-15

Where the grading falls outside the limits of any particular grading zone of sieves, other than 600 microns IS sieve, by total amount not exceeding 5%, it shall be regarded as falling

within that grading zone. This tolerance shall not be applied to percentage passing the 600 micron IS sieve or to percentage passing any other sieve on the coarser limit of grading zone I or the finer limit of grading zone IV. Fine aggregates conforming to grading zone IV shall be used. Mix designs and preliminary tests shall show its suitability for producing concrete of specified strength and workability.

e) **Fineness Modulus**

The sand shall have a fineness modulus of not less than 2.0 or more than 3.5. The fineness modulus is determined by adding the cumulative percentages retained on the following IS sieve sizes (4.75 mm, 2.36 mm, 1.18 mm, 600 microns and 150 microns) and dividing the sum by 100.

COARSE AGGREGATE

Coarse aggregate for concrete, except as noted above, shall conform to IS 383 & IS 2386. This shall consist of crushed stone and shall be clean and free from elongated, flaky or laminated pieces, adhering coatings, clay lumps, coal residue, clinkers, slag, alkali, mica, organic matter or other deleterious matter.

Screening and Washing: Crushed rock shall be screened and/ or washed for the removal of dirt or dust coating, if so requested by the Engineer-in-Charge.

Grading

i) Coarse aggregate shall be either in single size or graded, in both cases the grading shall be within the following limits:

BIS Sieve Size (mm)	Percentage passing for single sized aggregate of normal size					Percentage Passing For Graded Aggregate Of Normal Size			
	40 mm	20 mm	16 mm	12.5m m	10mm	40 mm	20 mm	16 mm	12.5m m
63	100	-	-	-	-	100	-	-	-
40	85-100	100	-	-	-	95-100	-	-	-
20	0-20	85-100	100	-	-	30-70	95-100	100	-
16	-	-	85-100	100	-	-	-	90-100	-
12.5	-	-	-	85-100	100	-	-	-	90-100
10	0-5	0-20	0-30	0-45	85-100	10-35	25-35	30-70	40-85
4.75	-	0-5	0-5	0-10	0-20	0-5	0-10	0-10	0-10
2.36	-	-	-	-	0-5	-	-	-	-

ii) The pieces shall be angular in shape and shall have granular or crystalline surfaces. Friable, flaky and laminated pieces, mica and shale, if present, shall be only within tolerance limits which will not affect adversely the strength and or durability of concrete. The maximum size of coarse aggregate shall be 40 mm for M-7.5 and M-10 and 20mm for M-15 to M-30 concrete, or as directed by the Engineer-in-charge or specified. The maximum size of coarse aggregate shall be the maximum size specified above but in no case greater than 1/4th of the minimum thickness of the member, provided that the concrete can be placed without difficulty so as to surround all reinforcement thoroughly and fill the corners of the form. For plain concrete the maximum size of aggregate shall be of 40 mm. For heavily reinforced concrete members, the nominal maximum size of the aggregate shall be 5 mm less than the minimum clear distance between the reinforcing main bars or 5 mm less than the minimum cover to reinforcement whichever is smaller.

Foreign material limitations

The percentage of deleterious materials in the aggregate delivered to the mixer shall not exceed the following:

Table 4 : Foreign Material Limitations in Coarse Aggregate

Sr. No.	Foreign Material	Percentage by Weight	
		Uncrushed	Crushed
1	Material finer than 75 micron BIS Sieve	3.0	3.0
2	Coal and lignite	1.0	1.0
3	Clay Lumps	1.0	1.0
4	Soft Fragments	3.0	-
	Total	8.0	5.0

Water

Water used for washing, mixing and curing shall be free from injurious amounts of deleterious materials. Potable water is generally satisfactory for mixing and curing concrete. Physical and chemical analysis of the water should be submitted to the Engineer-in-charge, before starting the work.

In case of doubt, the suitability of water for making concrete shall be ascertained by the compressive strength and initial setting time test specified in BIS 456. The sample of water

taken for testing shall be typical of the water proposed to be used for concreting, due account being paid to seasonal variation. The sample shall not receive any treatment before testing other than that envisaged in the regular supply of water proposed for use in concrete. The sample shall be stored in a clean container previously rinsed out with similar water.

Average 28 days compressive strength of at least three 15 cm concrete cubes prepared with water proposed to be used shall not be less than 90% of the average strength of three similar concrete cubes prepared with distilled water. The cubes shall be prepared, cured and tested in accordance with the requirements of BIS 516.

The initial setting time of test block must be made with the appropriate test cement and the water proposed to be used. It shall not be less than 30 minutes and shall not differ by more than +/-30 minutes from the initial setting time of control test block prepared with the appropriate test cement and distilled water. The test block shall be prepared and tested in accordance with the requirements of BIS 4031.

Where water can be shown to contain an excess of acid, alkali, sugar or salt, Engineer-in-charge may refuse to permit its use. As a guide, the following concentrations represent the maximum permissible values.

To neutralize 200 ml sample of water, using phenolphthalein as indicator, it should not require more than 2 ml of 0.1 normal NaOH. The details of test shall be as given in BIS 3025.

To neutralize 200 ml sample of water, using methyl orange as an indicator, it should not require more than 10 ml of 0.1 Normal HCl. The details of test shall be as given in BIS 3025.

Percentage of solids, when tested in accordance with the method indicated below shall not exceed the following:

Solids	Percent	Method of test
Ref. to col. no in IS:3025) Organic		
(organic solid = total solids minus ignited residue)	0.02	10 and 11
Inorganic	0.03	11(ignited residue)
Sulphates (as SO ₄)	0.05	20
Alkali Chlorides (as Cl)	0.20	24
Suspended matter	0.20	12
The pH value of water shall not generally be less than 6.		

Steel and Aluminum Members Encased in Concrete

Structural steel and aluminum ladders etc. to be encased in concrete shall be without paint. Primer should be used for encasing purpose. The encasing shall be done in concrete with 10 mm, maximum size aggregate and works cube strength not less than 150 kg/sq.cm. at 28 days unless otherwise specified. The member shall be wrapped with galvanized aluminum wire mesh of adequate size. The galvanized aluminum wire mesh shall be kept 20 mm from the edge or surface of the member and shall be held in position securely. The member will have a minimum cover of 50 mm unless otherwise indicated in the drawings. Where the clear cover is more than 75 mm, concrete with 20 mm coarse aggregate can be used.

Anchor Bolts, Anchors, Sleeves, Inserts, Hangers/Conduits/Pipe and Other Misc. Embedded Fixtures

The contractor shall build in to concrete work all the items mentioned in Drawings or Engineer In Charge and shall embed them partly or fully as directed and secure the same as may be required. The materials if required to be supplied by the contractor, shall be as specified and be of best quality available according to relevant Indian standards of approved manufacture and to the satisfaction of the engineer. Exposed surface of embedded materials is to be painted with one coat of approved anti-corrosive paint and/ or bituminous paint without any extra cost to the owner. If welding is to be done subsequently on the exposed surface of embedded material the paint shall be cleaned off the member to a minimum length of 50 mm beyond each side of the weld line.

Necessary templates, jigs, fixtures, supports etc. shall be used as may be required or directed by the Engineer In Charge.

Controlled Concrete

All concrete in the works shall be “Controlled Concrete” as defined in IS: 456 except for M-7.5 and M-10 for which normal mix concrete shall be used. Whether reinforced or otherwise, all concrete works to be carried out under this specification shall be divided into the following classifications:

Minimum Compressive Strength of 15 cm cubes at 7 days and 28 days after mixing, conducted in accordance with IS: 516.

Any operation of concrete done at atmospheric temperature above 40 degree C or where the temperature of concrete at the time of placement is expected to be beyond 40 degree C may be categorize as hot weather concreting and should be confined to the requirement of IS 7861(Part-I) 1975 and SP-23 (S&T)-1982.

Class	Preliminary Test N/mm ²		Works Test N/mm ²		Max. Size Of Aggregate mm	Locations For Use
	At 7 Days	At 28 days	At 7 days	At 28 days		
M40	33.5	50.0	27.0	40.0	20	As indicated in the specifications or as required
M35	30.0	44.0	23.5	35.0	20	
M30	25.0	38.0	20.0	30.0	40 or 20	
M25	22.0	32.0	17.0	25.0	40 or 20	
M20	17.5	26.0	13.5	20.0	40 or 20	
M15	13.5	20.0	10.0	15.0	40 or 20	

Note: It shall be very clearly understood that whenever the grade of concrete such as M-20, etc. is specified it shall be contractor’s responsibility to ensure the minimum crushing strength stipulated for the respective grade of concrete is obtained at works.

Mix Design

General

This is essential for investigating the grading of aggregates, water-cement ratio, workability and the quality of cement required to give preliminary and works cubes of the minimum strength specified. The proportions of the mix shall be determined by weight. Adjustment of aggregate proportions due to moisture present in the aggregate shall be made. Determination of mix proportions shall be carried out according to “Recommended guidelines for Concrete Mix Design” conforming to IS: 10262.

Whenever there is a change either in required strength of concrete, or water-cement ratio or workability or the source of aggregates and/or cement, preliminary tests shall be repeated to determine the revised proportions of the mix to suit the altered conditions. While designing proportions, over-wet mixes shall always be avoided.

While fixing the value for water/cement ratio for preliminary mixes, assistance may be derived from the graph (Appendix A, BIS 456 showing the relationship between the 28 day compressive strengths of concrete mixes with different water/cement ratios and the 7-day compressive strength of cement tested in accordance with IS: 269.

Preliminary Tests

Test specimens shall be prepared with at-least two different water/cement ratios for each class of concrete, consistent with work ability required for the nature of the work. The materials and proportions used in making preliminary tests shall be similar in all respects to those to be actually employed in the works as the object of these tests is to determine the properties of cement, aggregates and water necessary to produce concrete of required consistency and to give the specified strength, it will be contractor’s sole responsibility to carry out these tests and he shall therefore furnish to Engineer-in-Charge a statement of proportions proposed to be used for the various concrete mixes. For preliminary tests, the following procedure shall be followed.

Materials shall be brought to the room temperature and all materials shall be in a dry condition. The quantities of water cement and aggregates for each batch shall be determined by weight to an accuracy of 1 part in 100 parts.

Mixing concrete shall be done by hand (for small quantities, as directed by Engineer-in-Charge) or in a small batch mixer as per IS: 516 in such a manner as to avoid loss of water. The cement and fine aggregate shall first be mixed dry until the mixture is uniform in color. The coarse aggregate shall then be added, mixed and water added and the whole batch mixed thoroughly for a period of not less than two minutes until the resulting concrete is uniform in appearance. Each batch of concrete shall be such a size as to leave about 10% excess concrete, after moulding the desired number of test specimens.

The consistency of each batch of concrete shall be measured immediately after mixing, by the slump test in accordance with IS: 1199. If in the slump test, care is taken to ensure that no water or other material is lost, the material used for the slump test may be re-mixed with the remainder of the concrete for making the specimen test cubes. The period of re-mixing shall be as short as possible yet sufficient to produce a homogeneous mass.

The samples for compression tests of concrete shall be made as per IS: 516 on 15 cm cubes. Each mould shall be provided with a metal base plate having a plate surface so as to support the mould during filling without leakage. The base plate shall be preferably attached to the

mould by springs or screws. The parts of the mould when assembled shall be positively and rigidly held together. Before placing concrete, the mould and base plate shall be cleaned and oiled. The dimensions and internal faces of the mould shall be accurate within the following limits. Height and distance between the opposite faces of the mould shall be of specified size ± 0.2 mm. The angle between the adjacent internal faces and between internal faces and top and bottom faces of mould shall be 90-degree ± 0.5 degree. The interior faces of the mould shall be plane surfaces with a permissible variation of 0.03 mm.

Concrete test cubes shall be moulded by placing fresh concrete in the mould and compacted as specified in IS 516.

Curing shall be as specified in IS 516. The cubes shall be kept in moist air of at least 90% relative humidity at a temperature of 27 degree C ± 2 degree C for 24 hours ± 2 hours from the time of adding water to the dry ingredients. Thereafter they shall be removed from the moulds and kept immersed in clean, fresh water and kept at 27 degree C ± 2 degree C temperature until required for test. Curing water shall be renewed every seven days. A record of maximum and minimum temperatures at the place of storage of the cubes shall be maintained during the period they remain in storage.

The strength shall be determined based on not less than five cube test specimens for each age and each water cement ratio. All these laboratory test results shall be tabulated and furnished to the Engineer-in-Charge. The test results shall be accepted by the Engineer-in-Charge if the average compressive strengths of the specimens tested is not less than the compressive strength specified for the age at which specimens are tested subject to the condition that only one out of the five consecutive tests may give a value less than the specified strength for that age. The Engineer-in-Charge may direct the contractor to repeat the tests if the results are not satisfactory and also make such changes as he considers necessary to meet the requirements specified Proportioning, Consistency, Batching and Mixing of Concrete.

The determination of the water cement ratio and proportion of aggregates to obtain the required strength shall be made from preliminary tests by designing the concrete mix. Controlled concrete shall be used on all concrete work complying with all the requirements of IS: 456. Cube tests shall be carried out by the contractor on the trial mixes before the actual concreting operation starts. Based on the strength of the concrete mix sanction for the use has to be obtained from Engineer-in-Charge.

If during the execution of the works it is found necessary to revise the mix because of the cube tests showing lower strengths than the required one due to inconsistency of quality of material or otherwise, The Engineer-in-Charge shall ask for fresh trial mixes to be made by the contractor. No claim to alter the rates of concrete work shall be entertained due to such change in mix variations, as it is the contractor's responsibility to produce the concrete of the required grade.

Great care shall be exercised when mixing the actual works concrete using the proportions of the selected trial mix. The final concrete mix shall have the same proportions and same source of cement, fine and coarse aggregates and water as that of the approved selected mix.

A reasonable number of bags should be weighed separately to check the Net weight, where the weight of cement is determined by accepting the manufacturer's weight per bag at the site. Proper control of mixing water is deemed to be of paramount importance. If mixers with automatic addition of water are used, water should be either measured by volume in

calibrated buckets, tins or weighed. All measuring equipment shall be maintained in a clean serviceable condition and their accuracy periodically checked and certified and the Engineer-in-Charge's approval obtained.

The Engineer-in-Charge may require the contractor to carry out moisture content tests in both fine and coarse aggregates. The amount of the added water shall then be adjusted to compensate for any observed variations in the moisture contents. BIS: 2386 shall be referred to for determination of moisture content.

No substitution in material, used on the work or alteration in the established proportions shall be made without additional tests to show that the quality and strength of concrete are satisfactory. No alterations shall be permitted without the prior sanction of the Engineer-in-Charge.

Mixing of Concrete

The mixing of concrete shall be strictly carried out in an approved type of mechanical Concrete mixer. The mixing equipment shall be capable of combining the aggregates, Cement and water within the specified time into a thoroughly mixed and uniform mass, and of discharging the mixture without segregation. The entire batch shall be discharged before recharging. Mixing periods shall be measured from the time when all of the solid materials are in the mixing drum, provided that all of the mixing water shall be introduced before one fourth of the mixing time has elapsed. The mixing time in no case shall be less than two minutes. The mixer speed shall not be less than 14 nor more than 20 revolutions per minute.

Mixing shall be continued until there is a uniform distribution of the materials and the mass is uniform in color and consistency. Hand mixing of concrete shall not be permitted at all.

For quantities less than 1 cum of concrete, hand mixing may be permitted at the discretion of the Engineer-in-Charge with 10% excess cement quantity.

Grade of Concrete

The different grades of concrete specified shall conform to the strengths as required by IS: 456-1987. Standard deviation shall be calculated as stated in 14.5 of IS: 456-1978. The acceptable criteria for concrete shall be as stated in clause 15 of IS: 456 -1978. The assumed standard deviations as given in table 6 of IS: 456-1978 has to be followed and are given here under. However, the minimum cement content shall be as per *Table no. 7: Minimum Cement Content in Concrete* in this tender document.

Table 5: Grade of Concrete

Grade of Concrete	Assumed Standard Deviation N/sq.mm
M 10	2.3
M 15	3.5
M 20	4.6
M 25	5.3

In order to get a quick idea of quality of concrete the optional tests are conducted as stipulated in 14.1.1 of IS: 456-1978 and the results are analyzed according to table 5 on page 41 of IS: 456-1978.

Controlled Concrete

Controlled concrete shall be used on all concreting works except where specified otherwise the mix proportions for all grades of concrete shall be designed to obtain strengths corresponding to the values specified in table below for respective grades of concrete.

Table 6: Compressive Strengths at 28 days

Grade	Specified Characteristic Compressive Strength at 28 days (N/sq.mm)
M15	15
M20	20
M25	25
M30	30

The maximum Water : Cement ratio for all controlled concrete works shall be as specified in IS: 456-1978 as Preliminary tests as specified in the BIS code and required by the Engineer-in-charge shall be carried out sufficiently ahead of the actual commencement of the work with different grades of concrete made from representative samples of aggregates and cement expected to be used on the job to ascertain the ratios by weight of cement of total quantity of fine and coarse aggregates and the water cement ratio required to produce a concrete of specified strength and desired workability.

The minimum cement content for each grade of concrete shall be as per table below.

Table 7: Minimum Cement Content in Concrete

Grade of Concrete	Minimum Cement Content in Concrete (kg/cum of finished Concrete)
M 15	300
M 20	330
M 25	360
M 30	400

At least 4 (four) trial batches are to be made and 7 test cubes should be taken for each batch noting the slump on each mix. These cubes shall then be properly cured and two cubes from each mix shall be tested in a testing laboratory approved by the Engineer-in-Charge at 7 days and others at 28 days for obtaining the ultimate compressive strength. The test reports shall be submitted to the Engineer in charge. The cost of mix design and testing shall be borne by the contractor. On the basis of the preliminary test reports for trial mix, a proportion of mix by weight and water cement ratio will be approved by the Engineer-in-Charge, which will be expected to give the required strength. Consistency and workability and the proportions so decided for different grades of concrete shall be adhered to during all concreting operations. If however at any time the Engineer-in-Charge feels that the quality of material, being used has been changed from those used for preliminary mix design, the contractor shall have to run similar trial mixes to ascertain the mix proportions and consistency.

The mix once approved must not be varied without prior approval of the Engineer-in-Charge. However should the contractor anticipate any change in the quality of future supply of materials than that used for preliminary mix design, he shall inform the same to the Engineer-in-Charge and bring fresh samples sufficiently ahead to carry out fresh trial mixes. The Engineer-in-Charge shall have access to all places and laboratory where design mix is prepared. Design mix will indicate by means of graphs and curves etc. the extent of variation in the grading of aggregates which can be allowed.

In designing the mix proportions of concrete, the quantity of both cement and aggregate shall be determined by weight. All measuring equipment shall be maintained in clean and serviceable condition and their accuracy periodically checked.

To keep the water cement ratio to the designed value, allowance shall be made for the moisture contents in both fine and course aggregates and determination of the same shall be made as frequently as directed by the Engineer-in-Charge. The determination of moisture contents shall be according to IS: 2386 (Part III). Absorption of water by dry aggregates shall not be more than 5%.

Strength Requirements

Where ordinary Portland cement conforming to IS: 269 or Portland blast furnace slag cement conforming to IS: 455 is used the compressive strength requirements for various grades of concrete shall be as shown in table below. Where rapid hardening Portland cement is used the 28 days compressive strength requirements specified in Table- hereunder shall be met in 7 days. The strength requirements specified in table shall apply to both controlled concrete and ordinary concrete.

Strength Requirements of Concrete

Grade of Concrete	Minimum Compressive Strength Concrete in Accordance with IS: 516 (In kg/cm)
----------------------	--

As per IS: 456-1978

For 15 cm cube specimens

	at 7 days		at 28 days	
	Work Test	Preliminary	Work Test	
M 15	100	200	150	
M 20	135	260	200	
M 25	170	320	250	
M 30	200	380	300	

Other requirements of concrete strength as may be desired by the Engineer-in-Charge shall be in accordance with Indian Standard IS: 456 (latest revision). The acceptance of strength of concrete shall be as per clause 5.4 “Sample size and Acceptance Criteria” of IS: 456 (latest revision) subject to stipulation and/or modifications stated elsewhere in this specification if any.

Concrete work found unacceptable shall have to be dismantled and replaced to the satisfaction of the Engineer-in-Charge by the Contractor free of cost to the Owner. No payment will be made for the dismantled concrete, the relevant formwork and reinforcement, embedded mixtures etc. wasted in the dismantled portion shall be made. In

the course of dismantling if any damage is done to the embedded items or adjacent structures, the same shall also be made good free of charge by the contractor to the satisfaction of the Engineer in charge. If the water quantity has to be increased in special cases, cement also has to be increased proportionately to keep the ratio of water to cement same as adopted in trial mix design for each grade of concrete.

Workability

The workability of concrete shall be checked at frequent intervals by slump test. Where facilities exist and if required by the Engineer-in-Charge, alternatively the compacting factor test in accordance with IS: 1199 shall be carried out. The degree of workability necessary to allow the concrete to be well consolidated and to be worked into the corners of form work and round the reinforcement to give the required surface finish shall depend on the type and nature of the structure and shall be based on experience and tests. The limits of consistency for structures are as specified in the table below:

Table 8: Limits of Consistency

Placing Conditions	Degree of Workability	Values of Workability
Concreting of shallow Sections with vibration	Very low	20-10 seconds Veebee time or 0.75-0.80 compacting factor
Concreting of lightly Reinforced sections With vibration	Low	10-5 seconds or 0.80-0.85 compacting factor
Concreting of lightly Reinforced sections Without Vibration or Heavily reinforced Section with Vibration	Medium	5-2 seconds Veebee time or 0.85-0.92 compacting factor or 25-75mm slump for 20 mm Aggregate
Concreting of heavily Reinforced sections compacting Without vibration factor	High	Above 0.92 compacting factor or 75-125 mm slumps for 20 mm aggregate

Workmanship

All workmanship shall be according to the latest relevant standards. Before starting a pour the contractor shall obtain the approval of the Engineer-in-Charge and all other concerned department including safety dept, in a "Pour Card" maintained for this purpose. He shall obtain complete instructions about the material and proportion to be used, slump, workability of water per unit of cement, number of test cubes to be taken, finishing to be done and any admixture to be added etc.

SAMPLING AND TESTING CONCRETE IN THE FIELD

Sampling and Testing of Concrete shall conform to IS: 456 2000.

- a) Facilities required for sampling materials and concrete including whether proof buildings to house the facilities in the field, shall be provided by the contractor at no extra cost. The following equipment with operator shall be made available in serviceable conditions.
 - i. Concrete cube-testing machine suitable for 15 cm cubes of

	100 tonnes capacity with proving calibration ring	1 no.
ii.	Cast iron cube moulds 15 cm size	12 nos.
iii.	Slump cone complete with tamping rod	1 set
iv.	Laboratory balance to weigh upto 5 kg with sensitivity of 10 gm	1 no.
v.	BIS sieves for coarse and fine aggregates	1 set
vi.	Set of measures from 5 litres to 0.1 litre	1 set
vii.	Electric oven with thermostat upto 120° C	1 no.
viii.	Flakiness gauge	1 no.
ix.	Elongation index gauge	1 no.
x.	Sedimentation pipette	1 no.
xi.	Calibrated glass jar 1.0 litre capacity	2 nos.
xii.	Glass flasks and metal containers	As required
xiii.	Chemical reagents like sodium hydroxide, tannic acid, litmus paper etc. -	As required
xiv.	Laboratory balance of 2 kg capacity and sensitivity of 1 gm -	1 no.
xv.	Weighing Machine for cement bags of 6 Nos.:	2 no.
xvi.	Vernier Calipers	As required.
xvii.	Thermometer for concrete	1 no.

No concrete of any kind may be placed until the field concrete testing laboratory as specified is provided to the satisfaction of the Engineer. The contractor shall notify the Engineer in advance of all concrete and concrete material testing as provided in the clause to provide the Engineer/his representative with an opportunity to witness all prescribed tests.

At least 6 test cubes of each class of concrete shall be made of every 50cum concrete or part thereof or from different batches as directed by Engineer-in-Charge. Such samples shall be drawn on each day for each type of concrete. Of each set of 6 cubes, three shall be tested at 7 days age and three at 28 days age. The cubes must be casted from various batches to arrive at an average strength. The laboratory test results shall be tabulated and furnished to the Engineer. The Engineer will pass the concrete if average strength of the specimens tested is not less than the strength specified, subject to the condition that only one out of three consecutive tests may give a value less than the specified strength but this shall not be less than 90% of the specified strength.

Consistency: Slump tests shall be carried out as often as requested by the Engineer and invariably from the same batch of concrete from which the test cubes are made. Slump tests shall be done immediately after sampling.

CONCRETE TESTS

The Engineer-in-Charge, may order tests to be carried out on cement, sand, coarse aggregate, water in accordance with the relevant Indian standards.

Tests on Cement shall include:

Fineness test

Test for normal consistency

Test for setting time

Test for soundness

Test for tensile strength
Test for compressive strength
Test for heat of hydration (by experiment and by calculations) in accordance with BIS 269

Tests on Sand shall include:

Sieve test
Test for organic impurities
Decantation test for determining clay and silt content
Specific gravity test
Test for unit weight and bulk age factor
Test for sieve analysis and fineness modulus

Tests on Coarse Aggregate shall include:

Sieve analysis
Specific gravity and unit weight of dry, loose and rodded aggregate
Soundness and alkali aggregate reactivity
Petrography examination
Deleterious materials and organic impurities
Test for aggregate crushing value

Any or all these tests would normally be ordered to be carried out only if the Engineer feels the materials are not obtained and shall be performed by the contractor at a test laboratory approved by Engineer-in charge. The contractor shall bear the charges of these optional tests.

Concrete not made to the requirements of specification in all respects may be rejected by the Engineer-in-Charge in which case it shall be removed and reconstructed entirely at the expense of the contractor.

Load Test on Members or Any Other Tests

In the event of any work being suspected of material or workmanship or both, the Engineer-in-charge requiring its removal and reconstruction may order, or the contractor may request that it should be load tested in accordance with the following provisions.

The test load shall be 125% of the maximum superimposed load for which the structure was designed. Such test load shall not be applied before 56 days after the effective hardening of concrete. During the test, struts strong enough to take the whole load shall be placed in position leaving a gap under the members. The test load shall be maintained for 24 hours before removal.

If within 24 hours of the removal of the load, the structure does not show a recovery of at least 75% of the maximum deflection shown during the 24 hours under load, the test loading shall be repeated after a lapse of at least 72 hours. The structure shall be considered to have failed to pass the test if the recovery after the second test is not at least 75% of the maximum deflection shown during the second test. If the structure is certified as failed by the Engineer-in-Charge, the cost of all the new construction and the load tests shall be borne by the contractor.

Any other tests, e.g. taking out in an approved manner concrete cores, examination and tests on such cores removed from such parts of the structure as directed by the Engineer-in-Charge, sonic testing etc. shall be carried out by the contractor, if so directed, at no extra cost.

Unsatisfactory tests

Should the results of any test prove unsatisfactory, or the structure shows signs of weakness, undue deflection or faulty construction, the contractor shall remove and rebuild the member or members involved or carry out such other remedial measures as may be required by the Engineer-in-Charge.

Admixtures

General

Admixtures may be used in concrete where required, only with the approval of the Engineer-in-Charge. However it should be seen that, with the passage of time, neither the compressive strength nor its durability is reduced. Calcium chloride shall not be used for accelerating set of the cement for any concrete containing reinforcement or embedded steel parts. When calcium chloride is permitted to be used, such as in mass concrete works, it shall be dissolved in water and added to the mixing water in an amount not to exceed 1.5% of the weight of the cement in each batch of concrete. When admixtures are used, the designed concrete mix shall be corrected accordingly. Admixtures shall be used as per manufacturer's instruction and in the manner and with the control specified by the Engineer-in-Charge.

Air Entraining Agents

Neutralized Vinson resin or other approved air in the concrete mix agents shall conform to the requirements of ASTM standard 6.260; Air Entraining Admixtures for Concrete. The recommended total air content of the concrete is 4% + 1%. The method of measuring air content shall be as per IS: 1199.

Water Reducing Admixtures

Water reducing lignosulfonate admixture may be added in quantities approved by the Engineer-in-Charge. The admixtures shall be added in the form of a solution.

Retarding Admixtures

Retarding agents may be added to the concrete mix in quantities approved by the Engineer-in-Charge.

Water Proofing Agent

Water proofing agents shall conform to IS: 2645.

Other Admixtures

The Engineer-in-Charge may at his discretion allow the contractor to use any other admixture in the concrete.

Preparation Prior to Concrete Placement, Final Inspection and Approval

Before the concrete is actually placed in position, the insides of the formwork shall be inspected to see that they have been cleaned and oiled. Temporary openings shall be provided to facilitate inspection, especially at bottoms of columns and wall forms, to permit removal of sawdust, wood shavings, binding wire, dirt etc. Openings shall be placed or holes drilled so that these materials and water can be removed easily. Such openings/holes shall be suitably plugged later.

The various agencies shall be permitted ample time to install drainage and plumbing lines, floor and trench drains, conduits, hangers, anchors, inserts, sleeves, bolts, frames and other miscellaneous embedment to be cast in the concrete as specified or required or as is necessary for the proper execution of the work as specified in the drawings.

All embedded parts, inserts, etc. supplied by the contractor shall be correctly positioned and securely held in the forms to prevent displacement during depositing and vibrating of concrete.

All anchor bolts shall be positioned and kept in place with the help of properly manufactured templates unless specifically waived in writing by the Engineer-in-Charge.

Slots, openings, holes, pockets etc. shall be provided in the concrete work in the position specified in drawing or required or as directed by the Engineer-in-Charge.

Reinforcement and other items to be cast in concrete shall have clean surfaces that will not impair bond.

Prior to concrete placement, all work shall be inspected and approved by the Engineer-in-Charge and if found unsatisfactory, concrete shall not be poured until after all defects have been corrected.

Approval by the Engineer-in-Charge of any and all materials and work as required herein shall not relieve the contractor from his obligation to produce finished concrete in accordance with the requirements of the specifications.

Rain or wash water

No concrete shall be placed in wet weather or on a water-covered surface. Any concrete that has been washed by heavy rains shall be entirely removed, if there is any sign of cement and sand having been washed away from the concrete mixture. To guard against damage, which may be caused by rains, the works shall be covered with tarpaulins immediately after the concrete has been placed and compacted before leaving the work unattended. Any water accumulating on the surface of the newly placed concrete shall be removed by approved means and no further concrete shall be placed thereon until such water is removed. To avoid flow of water over/around freshly placed concrete, suitable drains and sumps shall be provided. During summer season, temperature of water should be maintained, as per the criteria and for the same, icing should be done for concreting work.

Bonding Mortar

Immediately before concrete placement begins, prepared surfaces except formwork, which will come in contact with the concrete to be placed, shall be covered with a bonding mortar as specified.

The corrosive matters on the reinforcement should be removed by means of wire brush.

Laitance should be removed by means of chiseling from top concrete layer which was earlier concreted

Transportation

General

All buckets, containers or conveyors used for transporting concrete shall be mortar-tight, leak proof irrespective of the method of transportation adopted, concrete shall be delivered with the required consistency and plasticity without segregation or loss of slump. However, chutes shall not be used for transport of concrete without the written permission of the Engineer-in-Charge and concrete shall not be re-handled before placing.

Retempered or Contaminated Concrete

Concrete must be placed in its final position before it becomes too stiff to work. On no account, water shall be added after the initial mixing. Concrete, which has become stiff or has been contaminated with foreign materials shall be rejected and disposed off as directed by the Engineer-in-Charge.

Avoiding Segregation

Concrete shall, in all cases, be deposited as nearly as practicable directly, in its final position and shall not be re-handled to flow in a manner which will cause segregation, loss of materials, displacement of reinforcement, shuttering or embedded insets, or impair its strength. For locations where direct placement is not possible, and in narrow forms, the Contractor shall provide suitable drop and “Elephant Trunks” to confine the movement of concrete. Special care shall be taken when concrete is dropped from a height, especially if reinforcement is in the way, particularly in column and the walls.

Placing by Manual Labour

Except when otherwise approved by the Engineer-in-Charge, concrete shall be placed in the shuttering by shovels or other approved implements, and shall not be dropped from a height more than 1.0 m or handled in a manner, which will cause segregation.

Placing by Mechanical Equipment

The following specification shall apply when placing concrete by use of mechanical equipment is warranted considering the nature of work involved. The control of placing shall begin at the mixer discharge. Concrete shall be discharged by a vertical drop into the middle of the bucket or hopper and this principle of a vertical discharge of concrete shall be adhered to throughout all stages of delivery until the concrete comes to rest in its final position.

Types of Buckets

Central-bottom-dump buckets of a type that provides for positive regulation of the amount and rate of deposition of concrete in all dumping positions, shall be employed.

Operation of Bucket

In placing concrete in large open areas, the bucket shall be spotted directly over the position designated and then lowered for dumping. The open bucket shall clear the concrete already in place and the height of drop shall not exceed 1.0 m. The bucket shall be opened slowly to avoid high vertical bounce. Dumping of buckets on the swing or in any manner, which results in separation of ingredients or disturbance of previously placed concrete, will not be permitted.

Placement of Restricted Forms

Concrete placed in restricted forms by barrows, buggles, cars, short chutes or hand shoveling shall be subject to the requirement for vertical delivery of limited height to avoid segregation and shall be deposited as nearly as practicable in its final position.

Chuting

Where it is necessary to use transfer chutes, specific approval of Engineer-in-Charge must be obtained to type, length slopes, baffles, vertical terminals and timing of operations. These shall be so arranged that an almost continuous flow of concrete is obtained at the discharge and without segregation. Concrete should flow smoothly in the chute and there should not be any obstruction to the flow. To allow for the loss of mortar against the sides of the chutes, the first mixes shall have less coarse aggregate. During cleaning of chutes, the wastewater shall be kept clear of the forms. Concrete shall not be permitted to fall from the end of the chutes by more than 1.0 m. Chutes, when approved for use shall have slopes not flatter than 1 vertical, 3 horizontal and not steeper than 1 vertical, 2 horizontal. Chutes shall be of metal or metal lined end of rounded cross section. The slopes of all chute sections shall be approximately the same. The slopes of all chute sections shall be approximately the same. The discharge end of the chutes shall be maintained above the surface of the concrete in the forms.

Placing by Pumping/Pneumatic Placers

Concrete may be conveyed and placed by mechanically operated equipment e.g., pumps or pneumatic placers only with the written permission of the Engineer-in-Charge at no extra cost. The slump shall be held to the minimum necessary for conveying concrete by this method.

When pumping is adopted, before pumping of concrete is started, the pipeline shall be lubricated with one or two batches of mortar composed of one part cement and two parts sand. Care shall be taken to avoid stoppages in work once pumping has started.

When a pneumatic placer is used, the manufacturer's advice on layout of the pipeline shall be followed to avoid blockages and excessive wear. Restraint shall be provided at the discharge box to cater for the reaction at this end. Manufacturer's recommendations shall be followed regarding concrete quality and all other related matters when pumping/ pneumatic placing equipment is used. It should be noted that no extra payment is made for these items, if required and directed by Engineer-in-Charge.

Concrete in Layers

Concreting, once started, shall be continuous until the pour is completed. Concrete shall be placed in successive horizontal layers of uniform thickness ranging from 15 cm to 45 cm directed by Engineer-in-Charge. These shall be placed as rapidly practicable to prevent the formation of cold joints or planes of weakness between each succeeding layer within the pour. The thickness of each layer shall be such that it can be deposited before the previous layer has stiffened. The bucket loads or other units of deposit, shall be spotted progressively along the face of the layer with such overlap as will facilitate spreading the layer to uniform depth and texture with a minimum shoveling. Any tendency to segregation shall be corrected by shoveling stones into mortar rather than mortar on to stones. Such a condition shall be corrected by redesign of mix or other means, as directed by the Engineer-in-Charge.

Cover Blocks

Cover blocks of required size depending on the cover of the reinforcement as mentioned in the drawings shall be prepared in 1:3 cement mortar with fine aggregates and minimum compressive strength of 300 kg/sq.cm.

Bedding of Layers

The top surface of each pour and bedding planes shall be approximately horizontal unless otherwise instructed. Top layer should be rough and with key for further extension of work.

Compaction

Concrete shall be compacted during placing with approved vibrating equipment until the concrete has been consolidated to the maximum practicable density, as specified in the IS, is free of pockets of coarse aggregate and fits tightly against all form surfaces, reinforcement and embedded fixtures. Particular care shall be taken to ensure that all concrete placed against the form faces and into corners of forms against hardened concrete at joints is free from voids or cavities. The use of vibrators shall be consistent with the concrete mix and caution exercised not to over vibrate the concrete to the point that segregation results.

Type of Vibrators

Vibrators shall conform to BIS specifications. Type of vibrator to be used shall depend on the structures where concrete is to be placed. Shutter vibrators to be effective, shall be firmly secured to the formwork which must be sufficiently rigid to transmit the vibration and strong enough not to be damaged by it. Immersion vibrators in sufficient numbers and each of adequate size shall be used to properly consolidate all concrete. Tapping or external vibrating of forms by hand tools or immersion vibrators will not be permitted.

Use of Vibrators

The exact manner of application and the most suitable machines for the purpose must be carefully considered and operated by experienced men. Immersion vibrators shall be inserted vertically at points not more than 450 mm apart and withdrawn when air bubbles cease to come to the surface. Immersion vibrators shall be withdrawn very slowly. In no case shall immersion vibrators be used to transport concrete inside the forms. Particular attention be paid to vibration at the top of a lift e.g. in a column or wall.

Melding Successive Batches

When placing concrete in layers, which are advancing horizontally as the work progresses, great care shall be exercised to ensure adequate vibration blending and melding of the concrete between the succeeding layers.

Penetration of Vibrators

The immersion vibrator shall penetrate the layer being placed and also penetrate the layer below while the under layer is still plastic to ensure good bond and homogeneity between the two layers and prevent the formation of cold joints.

Vibrating against Reinforcement/Formwork

Care shall be taken to prevent contact of immersion vibrators against reinforcement steel. Immersion vibrators shall not be allowed to come in contact with reinforcement steel after start of initial set. They shall also not be allowed to come in contact with forms or finished surfaces.

Use of Form Attached Vibrators

Form attached vibrators shall be used only with specific authorization of the Engineer-in-charge.

Use of Surface Vibrators

The use of surface vibrators will not be permitted under normal conditions. However, for thin slabs, surface vibrating by specially designed vibrators may be permitted, upon approval of Engineer-in-Charge.

Stone Pockets And Mortar Pond ages

The formation of stone pockets and mortar pond ages in corners and against faces of forms shall not be permitted. Should these occur, they shall be dug out, reformed and refilled to sufficient depth and shape for thorough bonding, as directed by the Engineer-in-Charge.

Placement Interval

Except when placing with slip forms, each placement of concrete in multiple lift work, shall be allowed to set for at least 24 hours after the final set of concrete and before the start of a subsequent placement.

Special Provision in Placing

When placing concrete in walls with openings, in floors of integral slabs and beam construction and other similar conditions, the placing shall stop when the concrete reaches the top of the opening in walls or bottom horizontal surface of the slab, as the case may be.

Placing shall be resumed before the concrete in place takes initial set, but not until it has had time to settle as determined by the Engineer-in-Charge.

Placing Concrete Through Reinforcing Steel

When placing concrete through reinforcing steel, care shall be taken to prevent segregation of the coarse aggregate. Where the congestion of steel makes placing difficult, it may be necessary to obtain Engineer in-Charge's permission for temporarily moving the top steel aside for proper placement & for restoring reinforcement as per drawing.

Bleeding

Bleeding or free water on top of concrete being deposited into the forms, shall be the cause to stop the concrete pour and the conditions causing this defect corrected before any further Concreting is resumed.

Application of Araldite for Bonding of New and Old Concrete

General

Araldite epoxy resins will be used to bond fresh concrete to concrete that is fully cured, to give a monolithic bond capable of transmitting high stresses when traditional bonding agents such as cement slurry cannot always be relied upon to provide good adhesion which is particularly the case when large areas are involved.

The Araldite based formulation shall be applied to a suitably prepared concrete sub-strata and the fresh concrete poured as soon as possible, but always during the 'open time' of the adhesive.

Materials used shall be of best quality like CIBA, FOSROC or ROFF and approved by the Engineer-in-Charge.

Manufacturer's instructions shall be followed in all respects.

No separate payment shall be paid for this item of work.

Formulation

ARALDITE	GY250	100	Parts by weight
Hardener	HY825	20	Parts by weight
Hardener	HY830	20	Parts by weight
Hardener	HY850	20	Parts by weight
Silica Flour		20	Parts by weight

Application

The application of the adhesives shall be as per manufacturer standards.

Preparation of the Substrata

To obtain good adhesion, it is necessary to have clean and sound substrata. Preparation can be carried out using a variety of techniques including chemical treatment and mechanical methods such as grinding, milling, and abrading, planning and sand blasting. Dust and loose particles resulting from the pretreatment should be removed by vacuum cleaning or oil-free or blast.

Mixing

The resin and hardener should be thoroughly mixed in the dry filler. The mixed, ready to use adhesive should not contain lumps of unwetted filler and should be of uniform color. For a total weight of 1 kg or less hand mixing should be sufficient. For quantities in excess of 1 kg, the use of a mechanical mixer is recommended.

Pot life and 'Open time'

The pot life is the period during which the ready to use ARALDITE based formulation must be applied. After this period, the mix can no longer be worked and will have begun to set in its container. The table below indicates the pot life at different temperatures:

Mix Temperature	Pot life in minutes
------------------------	----------------------------

25° C	90 Minutes
30° C	60 Minutes
35° C	45 Minutes

(The figures in this table are for batches less than 1 kilogram).

The ‘Open time’ is the maximum period of time allowable between application of the ARALDITE adhesive and pouring the fresh concrete. Exceeding the ‘Open time’ would result in considerably reduced adhesion. The adhesive should be applied to the pre-treated substrata as soon as the components have been mixed and fresh concrete poured immediately afterwards.

Accurate knowledge of the ‘Open time’ is essential in case the work is interrupted. Table gives the ‘Open time’ of ARALDITE based formulations as a function of substrata temperature. In all cases, the adhesives shall be applied immediately after mixing. Any delay between mixing and application will reduce the ‘Open time’. Fresh concrete must be poured before the adhesive begins to gel. New to old concrete bonding is not recommended at temperatures below 5-Degree Centigrade, as curing cannot be assured under these circumstances.

Methods of Application

The shape and size of the concrete structure will determine the method of application used. The ARALDITE based adhesive may be applied by hand using brushed, brooms or any other suitable applicator.

Suitability of Fresh Concrete

Best results are obtained when the water/ cement ratio of the new concrete is low as is practicable.

Coverage

One kilogram of the mixed ARALDITE adhesive including hardeners and filler covers an area of 2 to 3 sqm. When applied with a stiff nylon bristle brush. However, the coverage is very much dependent on the finish in the concrete.

Handling Precautions

Epoxy resins can cause irritation of the skin in sensitive person if incorrectly handled. Certain safety precautions must therefore be observed and those handling the resins and hardeners should be given suitable instructions. Those working with epoxy resins should, above all, be instructed that personal cleanliness at the place of work is essential. The resin and hardener should not be allowed to come into direct contact with the skin. The most effective protection is achieved by wearing rubber or polythene gloves, the latter having the advantage that they can be replaced when dirty. They are more pleasant to wear if cotton gloves are worn underneath. Parts of the skins, which have come into contact with the resin or hardener, should be washed with lukewarm water and a mild soap. Special cleaning creams may be used as they have proved to be highly suitable.

Construction Joints

A construction joint is defined as a joint in the concrete introduced for convenience in construction at which special measures are taken to achieve subsequent continuity without provision for further relative movement.

No concreting shall be started until the Engineer-in-Charge has approved the method of placing the positions and form of the construction joints and lifts. The construction joints

shall be so located as not to impair the strength of the structure. Water stops shall be inserted as per clause 3.20

Concrete placed to form the face of a construction joint shall have all Laitance removed and the aggregate exposed prior to the placing of fresh concrete. The Laitance shall wherever practicable be removed by spraying the concrete where it is still green. The whole of the concrete surface forming part of the joint shall be hacked to expose the aggregate to the 1/3rd size of maximum size of aggregate. Where aggregate is damaged during hacking, it shall be removed from the concrete face by further hacking. All loose matter shall be removed and the exposed surface thoroughly cleaned by wire brushing, air blasting or washing, leaving the surface clean and damp. Immediately before fresh concrete is placed, a 12 mm thick layer of sand/cement mortar mixed in the same proportions as in the concrete shall be spread in the horizontal face of the construction joint. A drier mix shall be used for the top lift of horizontal face of the construction joint. A drier mix shall be used for the top lift of horizontal pours to avoid Laitance. The new concrete shall be well worked against the prepared face before the mortar sets. Special care shall be taken to obtain thorough compaction and to avoid segregation of the concrete along the joint plane.

Movement Joints

Movement joints are defined as all joints intended to accommodate relative movement between adjoining parts of a structure, special provision being made where necessary for maintaining the water tightness of the joint. The contractor shall comply with the instructions of manufacturers of proprietary jointing materials and shall, if required by the Engineer-in-Charge, demonstrate that the jointing materials can be applied satisfactorily.

The surface of set concrete in a movement joint shall, as shown on the drawings, be painted with two coats of bituminous paint and new concrete shall be placed against it only when the paint is dry. Expansion joints shall be formed by a separating strip of approved preformed joint filler.

Caulking grooves shall be provided. At all joints where a caulking groove is formed, immediately prior to caulking, the groove shall be wire brushed and loose material removed and blown out by compressed air. After the groove has dried, it shall be primed and caulked with approved sealing compound applied in accordance with the manufacturer's instructions. At all caulked joints, the face of the caulking strip and a width of concrete on either side shall be painted with two coats of paint having the same base as the sealing compound.

Water Stops and Joint Fillers

Water stops

At all construction, contraction and expansion joints in the water retaining structures and wherever specified or directed by the Engineer-in-charge, water stops shall be provided. The water stops shall be PVC type or of any other equivalent material as approved by the Engineer-in-charge. PVC water stops shall have a tensile strength of not less than 14 MN/m² and elongation at break of not less than 300%. Water stops shall not be exposed to direct sunlight for long periods. Before being concreted in water stops shall be cleaned of all foreign materials. Wherever provided, water stops shall be placed in such a manner that they are embedded in the adjacent sections of the panels for equal width.

As far as possible, jointing on site shall be confined to the making of butt joints in straight runs of water stops and all the joints should be monolithic. Where it is agreed with the Engineer-in-Charge that it is necessary to make an intersection or change of direction of any joint, other than a butt joint in a straight run on site, a preliminary joint, intersection or change of direction piece shall be made and submitted to such tests as the Engineer-in-Charge may require.

Flexible water stops shall be fully supported in the form work, free of nails and clear of reinforcement and other fixtures. Damaged water stops shall be replaced and during concreting care shall be taken to place the concrete so that water stops do not bend or distort or displace.

The different types of water stops to be used in liquid retaining structures will be as follows:

Table 9 : Types of Water Stops

Sr.	Type of Joint	Type of water stops
1.	Partial/complete Contraction joint in walls and slabs	230 mm wide, ribbed with hollow centre bulb & 6 mm minimum thickness
2.	Expansion joints in walls and slabs	230 mm wide, ribbed with hollow centre bulb & 9 mm minimum thickness
3.	Construction joint in raft	230 mm wide, ribbed with hollow centre bulb & 9 mm minimum thickness
4.	Construction joint in wall	230 mm wide, ribbed with hollow centre bulb & 6 mm minimum thickness
5.	Expansion joint raft	230 mm wide, ribbed with hollow centre bulb & 9 mm minimum thickness
6.	Partial/complete Contraction joint in raft	230 mm wide, ribbed with hollow centre bulb & 9 mm minimum thickness

Jointing fillers

Joint fillers shall be of durable, compressible and non-extruding material.

Details of jointing material required here. Type of joint, size or width of joint and joint filler material to be used with preferred brands if any.

Sealing Compounds

Horizontal joints shall, where used in water-retaining structures be sealed with a cold pouring polysulphide rubber sealing compound of quality equal to, or better than serviced "Paraseal". Horizontal joints in roofs, floors and other non-water retaining structures shall be sealed with an approved sealant with properties equal to or better than serviced "Paraplastic 41". Vertical joints and joints in the soffits of slabs in both water retaining as well as non-water retaining structures shall be sealed with a trowel or gun applied polysulphide rubber sealing compound such as serviced "Vertiseal" or equivalent. Sealing compounds shall be fully cured before water is permitted to come in contact. At 40° C, the curing time would be approximately 7 weeks for polysulphide compounds like CIBA, FOSROC or ROFF as approved by Engineer-in-charge.

Tolerances in Concrete Surfaces

Concrete surfaces for the various classes of unformed and formed finishes specified in various clauses shall comply with the tolerances shown in Table hereunder, except where different tolerances are expressly required by the specification.

In the table 'line and level' and 'dimension' shall mean the lines, levels and cross-sectional dimensions as specified and required.

Surface irregularities shall be classified as 'abrupt' or 'gradual'. Abrupt irregularities include by shall not be limited to offsets and fins caused by displaced or misplaced

formwork, loose knots and other defects in formwork materials, and shall be tested by direct measurement. Gradual irregularities shall be tested by means of a straight template for plane surfaces and 1.5 m long formed surfaces.

Class of finish	Maximum tolerance (mm) in:			Dimension
	Line & level	Abrupt irregularity	Gradual irregularity	
U 1	12	6	6	-
U 2	6	3	3	-
U 3	6	3	3	-
F 1	12	6	6	+12-6
F 2	6	6	6	+12-6
F 3	3	3	3	+6-

Curing, Protecting, Repairing and Finishing

Curing

All concrete shall be kept continuously in a damp or wet condition by ponding or by covering with a layer of sacking, canvas, hessian or similar materials and kept constantly wet for at least seven days from the date of placing concrete in case of OPC and 10 days in case of mineral admixture or blended cements are used. The period of curing shall be not less than 10 days for concrete exposed to dry and hot weather condition

Curing with Water

Fresh concrete shall be kept continuously wet for a minimum period of 10 days from the date of placing of concrete, following a lapse of 12 to 14 hours after laying of concrete. The curing of horizontal surfaces exposed to the drying winds shall however begin as soon as the concrete has hardened. Water shall be applied to formed surfaces immediately upon removal of forms. Quantity of water applied shall be controlled so as to prevent erosion of freshly placed concrete.

Continuous Spraying

Curing shall be assured by use of an ample water supply under pressure in pipes, with all necessary appliances of hose, sprinklers and spraying devices. Continuous fine mist spraying or sprinkling shall be used, unless otherwise specified or approved by the Engineer-in-Charge.

Alternate Curing Methods

Whenever in the judgement of the Engineer-in-Charge, it is necessary to omit the continuous spray method, a covering of clean sand or other approved means such as wet gunny bags, which will prevent loss of moisture from the concrete, may be used. No type of covering will be approved which would stain or damage the concrete during or after the curing period. Covering shall be kept continuously wet during curing period. For curing of concrete in sidewalks, floors, flat roofs of other level surfaces, the ponding method of curing is preferred. The method of containing the ponded water shall be approved by the Engineer-in-Charge. Special attention shall be given to edges and corners of the slabs to ensure proper protection to these areas. The ponded areas shall be kept continuously filled with water during the curing period.

Curing Compound

Surface coating type-curing compounds shall be used only by special permission of Engineer-in-Charge. Curing compounds shall be liquid type white pigmented, conforming to US Bureau of Reclamation specification. No curing compound shall be used on surfaces where future blending with concrete, water of acid proof membrane or painting is specified. Curing compound shall be used only after getting sufficient/satisfactory test results at site.

Curing Equipment

All equipment and materials required for curing shall be on hand and ready for use before concrete is placed.

Protecting Fresh Concrete

Fresh concrete shall be protected from defacements and damage due to construction operations by leaving forms in place for an ample period as specified in section D3 of this specification. Newly placed concrete shall be protected by approved means such as tarpaulins from rain, sun and winds. Steps as approved by the Engineer-in-Charge shall also be taken to protect immature concrete from damage by debris, excessive lading, vibration, abrasion or contact with other materials, etc. that may impair the strength and/or durability of the concrete. Workmen shall be warned against and prevented from disturbing green concrete during its setting period. If it is necessary that the workmen enter the area of freshly placed concrete, the Engineer-in-Charge may require that bridges be placed over the area.

Repair and Replacement of Unsatisfactory Concrete

General

Immediately after the shuttering is removed, the surface of concrete shall be very carefully gone over and all defective areas called to the attention of the Engineer-in-Charge who may permit patching of the defective areas or also reject the concrete unit either partially or in its entirety. Rejected concrete shall be removed and replaced by the contractor. Holes shall be filled with mortar composed of one part of cement to one and half parts of sand passing 2.36 mm I.S sieve after removing any loose stones adhering to the concrete. Concrete surfaces shall be finished as described in specifications or as directed by the Engineer-in-Charge. Superficial honey combed surfaces and rough patches shall be similarly made good immediately after removal of shuttering, in the presence of the Engineer-in-charge and superficial water and air holes shall be filled in. The mortar shall be well worked into the surface with a wooden float. Excess water shall be avoided. Unless instructed otherwise by the Engineer-in-Charge, the surface of the exposed concrete placed against shuttering shall be rubbed down immediately on removal of shuttering to remove fine or other irregularities, care being taken to avoid damaging the surface. Surface irregularities shall be removed by grinding. If reinforcement is exposed or the honeycombing occurs at vulnerable positions e.g. ends of beams or columns, it may be necessary to cut out the member completely or in part and reconstruct. The decision of the Engineer-in-Charge shall be final in this regard. If only patching is necessary, the edges being cut perpendicular to the affected surface or with a small under cut if possible. Anchors, tees or dovetail slots shall be provided whenever necessary to attach the new concrete securely in place. An area extending several centimeters beyond the edges and the surfaces of the prepared voids shall be saturated with water for 24 hours immediately before the patching material is placed.

For small repairs concerned Engineering-Charge shall permit to repair the same and shall be repaired at his directions. For major repairs contractor shall submit the method of statement and on approval of same shall carry such repairs with strict compliance to the method of statement.

Use of Epoxy

The use of epoxy for bonding fresh concrete used for repairs will be permitted upon written approval of the Engineer-in-Charge. Epoxies shall be applied in strict accordance with the instructions of the manufacturer.

Method of Repair

Small size holes having surface dimensions about equal to the depth of the hole, holes left after removal of form bolts, grout insert holes and slots cut for repair of cracks shall be repaired as follows.

The hole to be patched shall be roughened and thoroughly soaked with clean water until absorption stops. A 5 mm thick layer of grout of equal parts of cement and sand shall be well brushed into the surface to be patched, followed immediately by the patching concrete which shall be well consolidated with a wooden float and left slightly protrude of the surrounding surface. The concrete patch shall be built up in 10 mm thick layers, after an hour or more, depending upon weather conditions, it shall be worked off flush with a wooden float and a smooth finish obtained by wiping with hessian. A steel trowel shall be used for this purpose. The mix for patching shall be of the same materials and in the same proportion as that used in the concrete being repaired, although some reduction in the maximum size of the coarse aggregates may be necessary and the mix shall be kept as dry as possible. Mortar filling by air pressure (gunniting) shall be used for repair of areas too large and/or too shallow for patching with mortar. Patched surfaces shall be given a final treatment to match the colour and texture of the surrounding concrete. White cement shall be substituted for ordinary cement, if so directed by the Engineer-in-Charge, to match the shade of the patch with the original concrete.

Curing of Patched Work

The patched area shall be covered immediately with an approved non-staining, water-saturated material such as gunny bags which shall be kept continuously wet and protected against sun and wind for a period of 24 hours. Thereafter, the patched area shall be kept wet continuously by a fine spray, or sprinkling for not less than 10 days. All fillings shall be tightly bounded to the concrete and shall be sound, free from shrinkage cracks after the fillings have been cured and dried.

Approval by the Engineer-in-Charge

All materials, procedures and operations used in the repair work shall be subject to the approval of the Engineer-in-Charge.

Finishing

General

The type of finish for formed concrete surfaces shall be as follows, unless varied by the design/architectural drawings and specifications.

When the structure is in service all the surfaces shall receive no special finish, except repair of damaged or defective concrete, removal of fine and abrupt irregularities, filling defective concrete, filling of holes left by form ties and rods and clean up of loose or adhering debris. Surfaces which will be exposed to the weather and which would normally be level, shall be sloped for drainage. Unless a horizontal surface or the slope required is specified, the tops of narrow surfaces such as stair treads, walls, curbs and parapets shall be sloped across the width approximately 1 in 30. Broader surfaces such as walkways, and platforms shall be sloped about 1 in 50. Surfaces that will be covered by backfill or concrete, subfloors to be covered with concrete topping, terrazzo or quarry tiles and similar surfaces shall be smooth ascended and leveled to produce even surfaces. Surface irregularities shall not exceed 6 mm. Surfaces which will not be covered by backfill, concrete or tile toppings such as outside decks, floors of galleries and sumps, parapets, gutters, side-walks, floors and slabs,

shall be consolidated, screened and floated. Excess water and laitance shall be removed before final finishing. Floating may be done with hand or power tools and started as soon as the screened surface has attained a stiffness to permit finishing operations and these shall be the minimum required to produce a surface uniform in texture and free from screened marks or other imperfections. Joints and edges shall be tooled as specified or as directed by the Engineer-in-Charge.

Standard Finish For Exposed Concrete

Exposed concrete shall mean any concrete, other than floors or slabs, exposed to view upon completion of the works. Unless otherwise specified, the standard finish for exposed concrete shall be a smooth finish. A smooth finish shall be obtained with the use of lined or plywood forms having smooth and even surfaces and edges. Panels of forms shall be of uniform size and be as large as practicable and installed with closed joints. Upon removal of forms the joint marks shall be smoothed off and all blemishes, protections etc., removed leaving the surfaces smooth.

Integral Cement Concrete Finish

When specified, an integral cement concrete finish of specified thickness for floors and slabs shall be applied either monolithic or bonded, as specified or directed by the Engineer-in-charge. The surface shall be tested with a straight edge and any high and low spots eliminated. Floating or trowelling of the finish shall be permitted only after all surface water has evaporated. Dry cement or a mixture of dry cement and sand shall not be sprinkled directly on the surface of the cement finish to absorb moisture or to stiffen the mix.

Rubbed Finish

A rubbed finish shall be provided only on exposed concrete surfaces. Upon removal of forms, all fins and other projections on the surfaces shall be carefully removed, offsets leveled and voids and/or damaged sections immediately saturated with water and repaired by filling with a concrete or mortar of the same composition as was used in the surface. The surfaces shall then be thoroughly wetted and rubbed with carborundum or other abrasive. Cement mortar may be used in the rubbing, but the finished surfaces shall not be brush coated with either cement or grout after rubbing. The finished surfaces shall present a uniform and smooth appearance.

Protection

All concrete shall be protected against damage until final acceptance by the Engineer-in-Charge.

Hot Weather Requirement

All Concrete work performed in hot weather shall be in accordance with IS:456, except as herein modified.

Admixtures may be used only when approved by the Engineer-in-Charge.

Adequate provisions shall be made to lower give limit concrete temperatures by cool ingredients, eliminating excessive mixing, preventing exposure of mixers and conveyors to direct sunlight and the use of reflective paint on mixers, etc. The temperature of the freshly placed concrete shall not be permitted to exceed 38 degrees centigrade.

Consideration shall be given to shading aggregate stockpiles from direct rays of the sun and spraying stockpiles with water, use of cold water when available, and burying, insulating, shading and/or painting white the pipelines and water storage tanks and conveyance.

In order to reduce loss of mixing water, the aggregate, wooden forms, subgrade, adjacent concrete and other moisture absorbing surfaces shall be well wetted prior to concreting, placement and finishing shall be done as quickly as possible.

Extra precautions shall be taken for the protection and curing of concrete. Consideration shall be given to continuous water curing and protection against high temperatures and drying hot winds for a period of at least 7 days immediately after concrete has set and after which normal curing procedures may be resumed.

Placing Concrete Underwater

- a) Under all ordinary conditions, all foundations shall be completely dewatered and concrete placed in the dry. However, when concrete placement under water is necessary, all work shall conform to IS:456 and the procedure shall be as follows:

Method of Placement

Concrete shall be deposited underwater by means of tremises, or drop bottom buckets of approved type.

Direction, Inspection and Approval

All work requiring placement of concrete underwater shall be designed, directed and inspected with due regard to local circumstances and purposes. All underwater concrete shall be placed according to specifications approved by the Engineer-in-Charge.

- b) Special precautions shall be taken for prevention of lifting of concrete due to uplift pressure of subsoil water.

Precast Concrete

General

Precast concrete units, whether manufactured on or off site, shall comply in every way with the provisions of the contract for in situ concrete. Wherever possible, precast units shall be hydraulically pressed. When ready for incorporation in the works, precast units shall be responsible for the accuracy of the level, shape of the bed or platform. A suitable serial number and the date of casting shall be impressed or painted on each unit.

Striking Forms

Side shutters shall not be struck in less than 24 hours after depositing concrete and no precast unit shall be lifted until the concrete reaches strength of at least twice the stress to which the concrete may be subjected to at the time of lifting.

Precast Units

The lifting and removal of precast units shall be undertaken without causing shock, vibration or undue bending stresses to or in the units. Before lifting and removal takes place, contractor shall satisfy the Engineer-in-Charge or his representative that the methods he proposes to adopt for these operations will not over-stress or otherwise effect seriously the strength of the precast units. The reinforced side of the units shall be distinctly marked.

Curing

All precast work shall be protected from the direct rays of the sun for at least 7 days after casting and during that period each unit shall be kept constantly watered or preferably be completely immersed in water if the size of the unit so permits.

Slots, Openings, Etc.

General

Slots, openings or holes, pockets, etc., shall be provided in the concrete work in the approved positions as per design drawings and as directed by Engineer-in-Charge and extra reinforcement should be provided as per design requirement. Short pipes with puddle collar shall be fixed in the side wall of suction pipes. They shall be supplied at the appropriate time during construction. Any deviation from the approved drawings shall be made good by contractor at his own expense, without damaging any other work. Sleeves, bolts, inserts etc., shall also be provided in concrete work where so required.

Grouting

Standard Grout

The proportions of grout shall be such as to produce a flowable mixture consistent with minimum water content and shrinkage. The grout proportions shall be limited as follows:

Table 10 : Proportions for Standard Grout

Sr.	Use	Grout thickness	Mix proportions	W/c ratio (max.)
1.	Fluid	Under 25 mm	One part Portland cement to one part sand	0.44
2.	General	25mm & over but less than 50mm	One part Portland cement To 2 parts of sand	0.53
3.	Stiff Mix	50mm & over	One part Portland cement to 3 parts of sand	0.53

Sand shall be such as to produce a flow able grout without any tendency to segregate. Sand for general grouting purposes shall be graded within the following limits:

Passing BIS 2.36 mm sieve 95 to 100%
Passing BIS 1.18 mm sieve 65 to 95%
Passing BIS 300 micron sieve 10 to 30%
Passing BIS 150 micron sieve 3 to 10%

Sand for fluid grouts shall have the fine material passing the 300 and 150 micron sieves at the upper limits specified above. Sand, for still grouts, shall meet the usual grading specifications for concrete laitance. Anchor bolts, anchor bolt holes and the bottoms of equipment and column base plates shall be cleaned of all oil, grease, dirt and loose material. The use of hot, strong caustic solution for this purpose will be permitted. Prior to grouting, the hardened concrete surfaces to be grouted shall be saturated with water. Water in anchor bolt holes shall be removed before grouting is started. Forms around base plates shall be reasonably tight to prevent leakage of the grout. Adequate clearance shall be provided

between forms and base plate to permit grout to be worked properly into place. Grouting, once started, shall be done quickly and continuously to prevent segregation, bleeding and breakdown of initial set. Grout shall be worked from one side of one end to the other to prevent entrapment of air. To distribute the grout and to ensure more complete contact between base plate and foundation and to help release trapped air, link chains can be used to work the grout into place. Grout throughout holes in base plates shall be by pressure grouting. Variations in grout mixes and procedures shall be permitted if approved by the Engineer-in-Charge.

Non-Shrinking Grout for Equipment Foundation

Non-shrinking grout shall be used for grouting of machine base plates, anchor bolts, other anchoring devices and at locations where ordinary grouts are ineffective due to shrinkage. It shall be composed of a type of expansive hydraulic sheeting binder and select-graded aggregates. It shall have properties as mentioned below:

Table 11 : Proportions for Non-Shrinking Grout

Sr.	Properties	Values
1	Maximum grain size	6 mm
2	Water % (for 80% flow)	15.17
3	Density of hardened grout	2.27 - 2.30 gm/ml
4	Compressive strength N/mm²	
	Minimum 3 days	23
	7 days	34
	28 days	45
5	Expansion %	
	Free	0.10 - 0.20
	Restrained	0.08 - 0.12
	Restrained	0.08 - 0.12

Mixing, batching, cleaning, preparation of surface and curing of non-shrinking grout shall be done as per manufacturer's instructions. Brands like FOSROC or BUILDMASTER etc. shall be used as per manufacturer specifications.

Inspection

All materials, workmanship and finished construction shall be subject to continuous inspection and approval of the Engineer-in-Charge.

All materials supplied by the Contractor and all work or construction performed by the Contractor which is rejected as not being in conformity with the specifications and requirements, shall be immediately replaced.

All concrete shall be protected against damage until final acceptance by the Engineer-in-Charge.

Clean-Up

Upon completion of the concrete work, all forms, equipment, construction tools, protective coverings and any debris resulting from the work shall be removed from the premises.

All debris i.e. empty containers, scrap wood, etc., shall be removed to "dump" daily, or as directed by the Engineer-in-Charge.

The finished concrete surfaces shall be left in a clean condition satisfactory to the Engineer-in-Charge.

Records of Concreting

An accurate and up to date record showing times, dates, weather and temperature conditions when various positions of all the concrete structures forming the works were concreted will be kept by the contractor and shall be countersigned by the Engineer-in-Charge. If the Contractor fails to sign the Engineer-in-Charge's record, it shall nevertheless be regarded as correct and binding on the Contractor.

The Contractor has to submit concrete pour card in duplicate duly to be signed to the Engineer-in-Charge for each type of concreting work. Contractor shall keep copy of it, after Engineer-in-Charge has checked and signed the pour card.

Foundation Bedding, Bonding and Jointing

In no case foundation shall rest on any loose strata or loose pockets etc. even though it has reached level shown on design drawings and referred back to design engineer / Engineer-in-Charge

All surfaces upon or against which concrete will be placed shall be suitably prepared by thoroughly cleaning, washing and dewatering, as specified or as the Engineer-in-Charge may direct, to meet the various situations encountered in the work.

Soft or spongy areas shall be cleaned out and backfilled with lean concrete or clean sand fill compacted.

Prior to construction of formwork for any item where soil will act as bottom form, approval shall be obtained from the Engineer-in-Charge for the suitability of the soil.

Preparation of Rock Strata of Foundations

To provide tight bond with rock foundations, the rock surface shall be prepared and the following general requirements shall be observed.

Concrete shall not be deposited on large sloping rock surfaces. Where required by the Engineer-in-Charge, the rock shall be cut to form rough steps or benches to provide roughness or a more suitable bearing surface.

Rock foundation stratum shall be prepared by picking, barring, wedging and similar methods which will leave the rock in an entirely sound and unshattered condition.

Shortly before concrete is placed, the rock surface shall be cleaned with high pressure water and air jet even though it may have been previously cleaned in that manner.

Prior to placing concrete, the rock surface shall be kept wet for a period of 2 to 4 hours unless otherwise directed by the Engineer-in-Charge.

Before placing concrete on rock surfaces all water shall be removed from depressions to permit thorough inspection and proper bonding of the concrete to the rock.

Formwork

Formwork, Fixing and General

All formwork shall be constructed of waterproof plywood or preferably sheet metal. Plywood used for form work shall be conforming to BIS: 4990 i.e. Specification for plywood for concrete shuttering works. The materials for formwork shall got approved by the Engineer-in-Charge before starting the work. Formwork shall be firmly supported, adequately strutted, braced and tied to withstand the placing and vibrating of concrete and the effects of weather. The tolerance on line and level shall not exceed 3 mm and the soffits of beams other than pre-stressed beams shall in the absence of any specified camber, be erected with an upward camber of 6 mm for each 3 meters of span.

The Contractor shall be responsible for the calculations and designs for the formwork, and if required, shall submit them to the Engineer-in-Charge for approval before construction. On form work to external faces, which will be permanently, exposed, all horizontal and vertical formwork joints shall be so arranged that joint lines will form a uniform pattern on the face of the concrete. Where the Contractor proposes to make up the form work for standard sized manufactured form work panels, the size of such panels shall be approved by the Engineer-in-Charge before they are used in the construction of the Works. The finished appearance of the entire elevation of the structure and adjoining structures shall be considered when planning the pattern of joint lines caused by form work and by construction joint to ensure continuity of horizontal and vertical lines.

Faces of form work in contact with concrete shall be free from adhering foreign matter, projecting nails and the like, splits or other defects, and all form work shall be clean and free from standing water, dirt, shavings, chippings or other foreign matter. Joints shall be sufficiently watertight to prevent the escape of mortar or the formation of fins or other blemishes on the face of the concrete and no bleeding should be allowed through the joints.

Form work shall be provided for the top surfaces of sloping work where the slope exceeds fifteen degrees from the horizontal (except where such top surface is specified as spaded finish) and shall be anchored to enable the concrete to be properly compacted and to prevent flotation, care being taken to prevent air being trapped.

Openings for inspection of the inside of the form work and for the removal of water used for washing down shall be provided and so formed as to be easily closed before placing concrete. Before placing concrete, all bolts, pipes or conduits or other fixtures which are to be built in shall be fixed in their correct positions, and cores and other devices for forming holes shall be held fast by fixing to the formwork or otherwise. Holes shall not be cut in any concrete without approval of the Engineer-in-Charge.

All exterior angles on the finished concrete of 90 degree or less shall be given 20 mm x 20 mm chamfers unless otherwise ordered by the Engineer-in-Charge.

No ties or bolts or other device shall be built into the concrete for the purpose of supporting formwork without the prior approval of the Engineer-in-charge. The whole or part of any such supports shall be capable of removal so that no part remaining embedded in the concrete shall be nearer than 50 mm from the surface in the case of reinforced concrete and 150 mm in the case of un-reinforced concrete. Holes left after removal of such supports shall be neatly filled with well rammed dry-pack mortar.

Formwork in contact with the concrete shall be treated with suitable non-staining mould oil to prevent adherence of the concrete except where the surface is subsequently to be

rendered. Care shall be taken to prevent the oil from coming in contact with reinforcement or with concrete at construction joints. Surface retarding agents shall be used only where ordered by the Engineer-in-Charge.

No formwork shall be started or placed unless the requirement work is fully completed and checked by Engineer-in-Charge.

Necessary cover blocks shall be provided before starting connection.

Removal of Formwork

Formwork shall be so designed as to permit any removal without resorting to hammering or levering against the surface of the concrete.

The periods of time elapsing between the placing of the concrete and the striking of the loads likely to be imposed on the concrete and shall in any case be not less than the periods shown in Table below. Where soffit formwork is constructed in a manner during and after such removal of a sufficient number of adequate supporting props in an undisturbed condition, the Contractor may, with the agreement of the Engineer-in-Charge, remove the formwork at the earlier times listed below provided that the props are left in position.

Table 12 : Period for Formwork

Position of formwork	Days for striking
Walls	1
Sides of beams and columns	2
Slabs (Drops left under)	3
Props to slabs (span not exceeding 4.5m)	7
Props to slabs (span exceeding 4.5 m)	14
Beams soffits (props left under)	7
Props to beams (span not exceeding 6 m)	14
Props to beams (span exceeding 6 m)	21
Circular structures, domes ,cantilever portions etc.	21

Notwithstanding the foregoing, the Contractor shall be held responsible for any damage arising from removal of formwork before the structure is capable of carrying its own weight and any incidental loading.

Striking shall be done slowly with utmost care to avoid damage to projections and without shock or vibration, by gently easing the wedges. If after removing the formwork it is found that timber has been embedded in the concrete. It shall be removed and made good as specified earlier.

Reinforced temporary openings shall be provided, as directed by the Engineer-in-Charge, to facilitate removal of formwork which otherwise may be inaccessible.

The rods, clamps, form bolts, etc. which must be entirely removed from walls or similar structures shall be loosened not sooner than 24 hours not later than 40 hours after the concrete has been deposited. Ties, except those required to hold forms in place, may be removed at the same time. Ties, withdrawn from walls and grade beams shall be pulled

toward the inside face. Cutting ties back from the faces of the walls and grade beams will not be permitted.

For liquid retaining structures, no sleeves for through bolts shall be used nor shall through bolts be removed as indicated above. The bolts, in this case, shall be cut at 25 mm depth or more from the surface and then the hole shall be made good by cement sand mortar of the same proportions as the concrete just after striking the form work.

Formed Surfaces - Classes of Finish

Finishes to formed surfaces of concrete shall be classified as F1, F2, or F3, or such other special finish as may be particularly specified. Where the class of finish is not specified the concrete shall be finished to Class F1.

Form work for Class F3 finish shall be lined with as large panels as possible of non-staining material with a smooth unblemished surface such as sanded plywood or hard compressed fiber board, arranged in a uniform approved pattern and fixed to back form work by oval nails. Unfaced wrought boarding or standard steel panels shall not be permitted.

Form work for Class F2 finish shall be faced with wrought tongued and grooved boards or plywood or metal panels arranged in a uniform approved pattern free from defects likely to detract from the appearance of the surface.

Form work for Class F1 finish shall be constructed in sheet metal. Surfaces subsequently to be rendered, plastered or tiled shall be adequately scabbled or hacked as soon as the form work is removed to reduce the irregularities to not more than half the thickness of such rendering, plastering or bedding for tiles and to provide a satisfactory key.

Defects in Formed Surfaces

Workmanship in formwork and concreting shall be such that concrete shall normally require no making good, surfaces being perfectly compacted and smooth.

If any blemishes are revealed after removal of formwork, the Engineer-in-Charge's decisions concerning remedial measures shall be obtained immediately. These measures may include, but shall not be limited to the following:

Fins, pinhole bubbles, surface discoloration and minor defects may be rubbed down with sacking immediately after the formwork is removed.

Abrupt and gradual irregularities may be rubbed down with carborundum and water after the concrete has been fully cured. These and any other defects shall be remedied by methods approved by the Engineer-in-Charge which may include using a suitable epoxy resin or, where necessary, cutting out to a regular dovetails shape at least 75 mm deep and refilling with concrete over steel mesh reinforcement sprung into the dovetail.

The form work shall be checked by the Engineer-in-Charge before the form work starts and form found defective shall be rejected and the same can be used after rectifying the defects and with due approval of the Engineer-in-Charge

Holes to be Filled

Holes formed in concrete surfaces by form work supports or the like shall be filled with dry-pack mortar made from one part by weight of ordinary Portland cement and one part fine

aggregate passing BIS sieve 1.18 mm. The mortar shall be mixed with only sufficient water to make the materials stick together when being molded in the hands.

The contractor shall thoroughly clean any hole that is to be filled with dry-pack mortar and where the surface has been damaged, the contractor shall break out any loose, broken or cracked concrete or aggregate. The concrete surrounding the hole shall then be thoroughly soaked after which the surface shall be dried so as to leave a small amount of free water on the surface. The surface shall then be dusted lightly with ordinary Portland cement by means of a small dry brush until the whole surface that will come into contact with the dry-pack mortar has been covered and darkened by absorption of the free water on the surface. The surface shall then be dusted lightly with ordinary Portland cement by means of a small dry brush until the whole surface that will come into contact with the dry-pack mortar has been covered and darkened by absorption of the free water by the cement. Any dry cement in the hole shall be removed.

The dry-pack material shall then be placed and packed in layers having a compacted thickness not greater than 15 mm. The compaction shall be carried out by use of a hardwood stick and a hammer and shall extend over the full area of the layer, particular care being taken to compact the dry-pack against the sides of the hole. After compaction, the surface of each layer shall be scratched the dry-pack fill and striking the block several times. Steel finishing tools shall not be used and water shall not be added to facilitate finishing.

Tolerances

Tolerance is a specified permissible variation from lines, grade or dimensions given in approved drawings. No tolerance specified for horizontal or vertical building lines or footings shall be construed to permit encroachment beyond the legal boundaries. Unless otherwise specified, the following tolerances will be permitted:

Tolerances for RCC Structures

- i. Variation from the plumb
 - In the lines and surfaces of columns, piers, walls 5 mm per 2.5 m or 25 mm, whichever is less.
 - For exposed corner columns and other conspicuous lines

In any bay or 5 m maximum	5 mm
In 10 m or more	10 mm

- ii. Variation from the level or from the grades indicated on the approved drawings
 - In slab soffits, ceilings, beam soffit, and in arises

In 2.5 m	5 mm
In any bay or 5 m maximum	10 mm
In 10 m or more	15 mm

 - For exposed lintels, sills, parapets, horizontal grooves and other conspicuous lines

In any bay or 5 m maximum	5 mm
In 10 m or more	10 mm

- iii. Variation of the linear building lines from established position in plan and related position of columns, wall and partitions

In any bay or 5 m maximum	10 mm
In 10 m or more	20 mm

- iv. Variation in the sizes and locations of sleeves, openings in walls and floors except in the case of and for 5mm anchor bolts
- v. Variation in cross sectional dimensions of columns and beams and in the thickness of slabs and walls
- | | |
|-------|-------|
| Minus | 5 mm |
| Plus | 10 mm |
- vi. Footings Variation in dimension in plan
- | | |
|-------|-------|
| Minus | 5 mm |
| Plus | 10 mm |
- vii. Misplacement or eccentricity 2% of footing width in the direction of misplacement but not more than 50 mm Reduction in thickness: Minus 5% of specified thickness subject to a maximum of 50 mm
- viii. Variation in steps
- In a flight of stairs
- | | |
|-------|------|
| Rise | 3 mm |
| Tread | 5 mm |
- In consecutive steps
- | | |
|-------|--------|
| Rise | 1.5 mm |
| Tread | 3 mm |
- Tolerances in other Concrete Structures
- ix. All structures
- Variation of the constructed linear outlines from established position in plan
- | | |
|-----------------|-------|
| In 5 m | 10 mm |
| In 10 m or more | 15 mm |
- Variations of dimensions to individual structural features from established positions
- | | |
|------------------------|-------|
| In 20 m or more | 25 mm |
| In buried construction | 50 mm |
- Variation from plumb, from specified batter or from curved surfaces of all structures
- | | |
|------------------------|-------------------------|
| In 2.5 m | 10 mm |
| In 5 m | 15 mm |
| In 10 m or more | 25 mm |
| In buried construction | twice the above amounts |
- Variation from level or grade indicated on approved drawings in slab, beams, soffits, horizontal grooves and visible arises
- | | |
|------------------------|-------------------------|
| In 2.5 m | 5 mm |
| In 7.5 m or more | 10 mm |
| In buried construction | Twice the above amounts |
- Variation in cross-sectional dimensions of columns, beams, buttresses, piers and similar members
- | | |
|-------|-------|
| Minus | 5 mm |
| Plus | 10 mm |
- x. Footings for columns, piers, walls, buttresses and similar members Variation of dimensions in plan

Minus	10 mm
Plus	50 mm
Misplacement or eccentricity	
2% of footing width in the direction of misplacement but not more than 50 mm.	
Reduction in thickness	
5% of specified thickness subject to a maximum of 50 mm	

- xi. Tolerance in other types of structures shall generally conform to those given in Clause 2.4 of Recommended Practice for Concrete Formwork (American Concrete Institute Act 347).
- xii. Tolerance in fixing anchor bolts shall be as follows:
- | | |
|------------------------------|----------------------------------|
| Anchor bolts without sleeves | + 5 mm |
| Anchor bolts with sleeves | + 5 mm for bolts up to 20 mm dia |
| 3 mm for bolts | above 32 mm dia |
| Embedded parts | + 5 mm in all directions |

Bracing, Struts and Props

Form work shall be braced, strutted, propped and so supported that it shall not deform under weight and pressure of the concrete and also due to the movement of men and other materials. Bamboo shall not be used as props or cross bearers.

The formwork for beams and slabs shall be so erected that the formwork on the sides of the beams and under the soffit of slabs can be removed without disturbing the beam bottoms. Repropping of beams shall not be done except when props have to be reinstated to take care of construction loads anticipated to be in excess of the design load. Vertical props shall be supported on wedges or other measures shall be taken whereby the props can be gently lowered vertically while striking the formwork.

If the formwork for a column is erected for the full height of the column, one side shall be left open and built up in sections as placing of the concrete proceeds, or windows may be left for pouring concrete from the sides to limit the drop of concrete to 1.0 m as directed by the Engineer-in-Charge.

Contractor shall submit the detailed design and methodology with applicable drawings if any of Formwork system for different members for approval of Engineer-in-Charge.

Reinforcement

Relevant IS Codes

IS:432	:	Mild steel and medium tensile steel bars & hard drawn steel wire for concrete reinforcement
IS:1786	:	Cold twisted steel bars for concrete reinforcement
IS:2502 (1963):		Code of practice for bending and fixing of bars for concrete reinforcement
IS:55225(1969):		Recommendations for detailing of reinforcement in RCC works
IS:2751	:	C.P. for welding of MS bars used for RCC
IS:9417	:	Recommendations for welding cold worked steel bars for RCC
IS:10790	:	Methods of sampling of reinforced steel

General

Reinforcement shall be high strength deformed corrosion resistant (CRS) bars as per IS:1786 – Fe415. Wire mesh or fabric shall be in accordance with IS:456. Substitution of reinforcement will not be permitted except upon written approval from the Engineer-in-Charge.

Storage

The reinforcement shall not be kept in direct contact with the ground but stacked on top of an arrangement of timber sleepers or the like.

If the reinforcing rods have to be stored for a long duration, they shall be coated with cement wash before stacking and/or be kept under cover or stored as directed by the Engineer-in-Charge.

Fabricated reinforcement shall be carefully stored to prevent damage, distortion, corrosion and deterioration.

It should be seen that the reinforcement will not be exposed to direct sunlight and preventive measures should be taken for the same.

Quality

All reinforcements shall be clean, free from grease, oil paint, dirt, loose mill scale, loose rust, dust bituminous material or any other substances that will destroy or reduce the bond. All rods shall be thoroughly cleaned before being fabricated. Pitted and defective rods shall not be used. No welding of rods to obtain continuity shall be allowed unless approved by the Engineer-in-Charge. If welding is approved, the work shall be carried out as per IS:1786 - Fe415 according to the best modern practices and as directed by the Engineer-in-Charge. In all cases of important connections, tests shall be made to prove that the joints are of full strength of bars welded. Special precautions, as specified by the Engineer-in-Charge, shall be taken in the welding of cold worked reinforcing bars and bars other than mild steel.

Laps

Laps and splices for reinforcement shall be as per IS: 456-2000. Splices in adjacent bars shall be staggered as mentioned in structural drawings and locations of all splices shall be approved by the Engineer-in-Charge.

Also contractor shall submit the Bar bending schedule for approval of Engineer-in-Charge and shall follow same unless and until changed by any design changes.

Bending

Reinforcement bars supplied bent or in coils, shall be straightened before they are cut to size. Straightening of bars shall be done cold and without damaging the bars.

All bars shall be accurately bent according to the sizes and shapes shown on the approved detailed working drawings/bar bending schedules. They shall be bent gradually by machine or other approved means. Reinforcing bars shall not be straightened and re-bent in a manner that will injure the material; bars containing cracks/splits shall be rejected. They shall be bent cold, except bars of over 25 mm in diameter, which may be bent hot if specifically, approved by the Engineer-in-Charge. Bars, which depend for their strength of cold working, shall not be bent hot. Bars bent hot shall not be treated beyond cherry red colour (nor exceeding 845°C) and after bending shall be allowed to cool slowly without quenching. Bars incorrectly bent shall be used only if the means used for straightening and re-bending be such as shall not, in the opinion of the Engineer-in-Charge, injure the material. No reinforcement shall be bent when in position in the work without approval, whether or not it is partially embedded in hardened concrete. Bars having kinks or bends other than those required by design shall not be used.

Fixing

Reinforcement shall be accurately fixed by any approved means and maintained in the correct position shown in the approved Drawings by the use of blocks, spacers and chairs, as per IS:2502 to prevent displacement during placing and compaction of concrete. Bars intended to be in contact at crossing points shall be securely bound together at all such points with number 16 gauge GI wire. The vertical distances required between successive layers of bars in beams or similar members shall be maintained by the provision of mild steel spacer bars at such intervals that the main bars do not perceptibly sag between adjacent spacer bars. No binding wire shall protrude in cover area and shall bent inside.

Cover

Unless indicated otherwise, clear concrete cover for reinforcement (exclusive of plaster or other decorative finish) shall be as follows:

At each end of a reinforcement bar, not less than 25 mm nor less than twice the diameter of the bar whichever is greater

For a longitudinal reinforcing bar in a column, not less than 40 mm, nor less than the diameter of the bar. In case of columns of minimum dimension of 20 cm or under with reinforcing bars of 12 mm and less in diameter, a cover of 25 mm may be used.

For longitudinal reinforcing bars in a beam, not less than 40 mm nor less than the diameter of the bar, whichever is greater

For tensile, compressive, shear or other reinforcement in a slab, or wall, not less than, 20 mm, nor less than the diameter of such reinforcement.

For any other reinforcement, not less than 20 mm, nor less than the diameter of such reinforcement.

For footing and other principal structural members in which the concrete is poured on a layer of lean concrete, the bottom cover shall be reduced to 60 mm.

For concrete surfaces exposed to the weather or the ground after removal of forms, such as retaining walls, grade beams, footing sides and tops, etc. not less than 40 mm for bars larger than 16 mm diameter and not less than 30 mm for bars 16 mm diameter or smaller.

For liquid retaining structures, the minimum cover to all steel shall be 40 mm or the diameter of the main bar, whichever is greater.

The correct cover shall be maintained by cement mortar cubes or other approved means. Reinforcement for footings, grade beams and slabs on subgrade shall be supported on

precast concrete blocks as approved by the Engineer-in-Charge. The use of pebbles or stones shall not be permitted.

The 28 day crushing strength of cement mortar cubes/precast concrete cover blocks shall be at least equal to the specified strength of concrete in which these cubes/blocks are embedded.

The minimum clear distance between reinforcing bars shall be in accordance with IS:456

Inspection

After final erection of reinforcement, it shall be intimated to Engineer-in-Charge in writing or through pour cards. Erected and secured reinforcement shall be inspected and approved by the Engineer-in-Charge prior to placement of concrete.

Welding OF Reinforcement

Reinforcement which is specified to be welded shall be welded by any process which conforms with the requirements of IS:2751 and which the Contractor can demonstrate by bend and tensile tests will ensure that the strength of the parent metal is not reduced and that the weld possesses a strength not less than that of the parent metal. The welding procedure established by successful test welds shall be maintained and no deviation from this procedure shall be permitted.

Welds in positions other than those shown on the approved Drawings shall not be permitted. Tack welding to lightly secure reinforcement in place will be permitted subject to approval of the Engineer-in-Charge.

Supply of Reinforcing Bars

Steel reinforcement, such as MS bars HYSD bars etc. required for the works shall be procured by contractor. Bidder shall consider use of any of the following brands of Steel bar reinforcements required for civil works for the proposed 14 MLD capacity Water Treatment Plant and associated works:

Steel bar reinforcement (Grade Fe 415): TISCON- CRS of TATA or High strength Rebar (Thermo-mechanically treated bar) of SAIL make.

The contractor shall arrange for transport, loading, unloading and storage at the work sites. The contractor should plan the procurement of steel in such a way that at least required quantity of steel of specified sizes is available at site for 3 months period.

Steel brought on site shall be stored in proper manner as approved by Engineer In Charge so as to avoid distortion, deterioration and corrosion. The contractor shall maintain proper register for the steel account, showing the steel received at site, steel used, and the balance stock on site, to the entire satisfaction of the Engineer-in-Charge

Structural Steel Work

Relevant IS Codes

IS:2062	:	Specification for Structural Steel (Fusion Welding Quality)
IS:800	:	C.P. for general construction in steel
IS:808	:	R.S. beam, channel and angel sections
IS:814	:	Covered electrodes for metal arc welding of structural steel
IS:1148	:	Hot rolled steel rivet bars for structural purpose
IS:1363	:	Black hexagon bolts, nuts, and lock nuts (dia 6 to 39mm) & black hexagon screws (dia 6 to 24mm)
IS:2062	:	Structural steel (fusion welding quality)
IS:3954	:	Hot rolled steel channel sections for general engineering purposes
SP-6 (I – VII)	:	ISI Handbook for Structural Engineers
SP-40	:	Handbook on structures with steel portal frames (without cranes)

General

Structural steel fabrication work shall include all types of steel structural work required for installation of platform for operation and installation of equipment where rolled steel sections are joined together either by bolting or riveting or welding as specified in the drawings/bill of quantities/directed by the Engineer. It shall also include fabrication and installation of air vessels/pressure vessels etc. Covers for ducts for electrical panels along with their seating arrangements are also classified under this heading unless they are provided separately under a different heading. Reaction tanks or storage vessels are also classified under this heading.

Materials

The MS structural members such as MS angles, channels, flats, I sections etc. shall conform IS 2062. Structural steel that is used for fabrication shall be conforming to any of the following grades of steel as specified to each of the works:

IS:2062	:	Specification for Structural Steel (Fusion Welding Quality)
IS:1977-1975	:	Structural steel (ordinary quality)
IS:2062-1980	:	Weld able Structural steel (fusion quality)

Whenever the contractor supplies steel, he shall on demand the test certificates from the manufacturer.

The welding rods used for fabrication shall conform to IS:814-1974 (parts I and II). The fasteners like bolts, nuts etc., shall conform to IS:1367. Rivets shall conform to IS:1184-1982. Plain washers shall conform to IS:2016-1967. Spring washers shall conform to IS:3063-1972.

MS rivets shall conform to IS:1148 and IS:1929-1967 bolts and nuts shall conform to IS:1363 - 1967.

If metal arc welding is to be done as per design or as ordered by the Engineer-in-charge the electrodes used for strength welds shall conform to IS: 814 and shall be of such shape and size approved by the Engineer-in-Charge and shall be prevented from oxidation and shall be kept in clean condition.

Paints used shall be of approved manufacture and shade and shall conform to the ISI standards.

Fabrication and Erection

All the shop drawings shall be prepared by the contractor and submitted in advance of at least 15 days to the Engineer for his approval. The drawings shall be submitted in triplicate. The fabrication work shall not be taken in hand until the shop drawings are approved by the Engineer. Approval of the shop drawings however shall not relieve the contractor of his responsibility of correct conformation to the designs and fabrications of the structure to meet the requirements of the contract. One copy of the approval drawings shall be given to the contractor for going ahead with the fabrication work.

In the shop drawings to be submitted by the contractor, standard symbols as described in the IS:813-1961 shall be followed.

Fabrication work shall be carried out as laid down in IS:800-1984 Code of practice for general construction in steel.

Welding shall be carried out in accordance with the following specifications as applicable:

IS:803 - 1976	:	Code of practice for design fabrication and erection of vertical mild steel cylindrical welded oil storage tanks.
IS: 816 - 1969	:	Code of practice for use of metal and welding for general construction in mild steel
IS:822 - 1970	:	Code of practice for manual and welding of mild steel
IS:9595 - 1980	:	Recommendations for metal are welding of carbon
Radiographic tests are required to be carried out as directed by the Engineer in case of pressure vessels.		
IS:818 - 1968	:	Code of practice for safety and health requirements in electric and gas welding and cutting operations
IS:3016-1982	:	Code of practice for fire precautions in welding and cutting operations
IS:7205 – 1973	:	Safety code for erection of structural steel work

The sections shall be fixed absolutely vertical or to the specified angle as shown in the drawings/as desired/directed by the Engineer.

All connections like angle brackets, cleats, gusset plates, anchor bolts, bearing plates shall all be fixed as shown in the drawings or as directed by the Engineer.

The items of work shall include supply of materials, fabrication and erection in position on site as shown in the drawings. This shall also include all labour consist, materials and equipment required for all fabrication, hoisting, erection, and satisfactory completion of the item of work.

The supply of materials includes all structural members like rolled sections, plates, brackets, rivets, bolts and nuts and welds.

The steelwork shall be painted as specified in the drawings, described in the bill of quantities or as directed by the Engineer. Unless otherwise provided for in the bill of quantities separately, the rate quoted for the item is inclusive of all costs for painting like cost of paint, cost of labour, scaffolding etc. Welding work shall be done generally using electric arcs welding. Where public electricity is not available, generators shall be arranged by the contractor shall be arranged by the contractor himself.

Gas welding shall not be allowed to be resorted to for welding. Under special circumstances if in the opinion of the Engineer it cannot be avoided, gas welding can be done with the prior permission of the Engineer. However gas welding shall not be used where structural strength is the criteria for consideration.

All arrangements shall be made by the contractors for access for inspection by the Engineer or his representative to the workshop where the welding work is being carried out and necessary equipment like gauges, measuring instruments etc., shall be made available to the inspecting personnel.

Painting work shall not be started without the express approval of the Engineer and the painting shall be started only after his inspection and approval of the works after carrying out surface preparations.

All holes shall be carefully marked. Holes shall have their axis perpendicular to the surfaces bored through. Holes being made through two or more members shall be truly concentric. Holes shall not be formed cutting process.

All the temporary connections of parts during assembly shall be done in the following ways. For welded structures. Tack welding fixtures.

After welding is over, the surface on the joint should be ground and made smooth and even. The welding should be so perfect so as to give required strength as taken for designed purpose at joints in particular. The contractor will make necessary arrangements for testing of joints as required by Engineer in Charge.

Welded joints shall be free from defects that would impair the service performance of the construction. All the welds shall be free from incomplete penetration, incomplete fusion, slag inclusion, burns, un-welded creases undercuts and cracks in the welded metal, porosity etc. All the defects shall be rectified as directed by the Engineer. Defective portions shall be removed to the sound metal and re-welded. Rectification of the welds by caulking shall not be permitted.

All welds shall be cleaned of slag and other deposits after completion.

Painting

Painting shall generally comply with IS subject to addition and alterations as may be prescribed in the special provisions for any particular item. It shall also comply with the requirements of the manufacture's specifications. One priming coat of red lead shall be applied immediately after fabrication. Two coats of oil paint of approved shade shall be applied after complete erection. The structural steel to be embedded in concrete shall not be painted.

Inspection and testing shall be carried out in conformity with IS:800.

Riveting, welding and bolting shall not be started until such time as the Engineer has personally satisfied himself that the alignment is correct, in the vertical plumb, the camber correct with camber packs, screwed tight, all joints and cover plates fixed tightened with service bolts and field rivet holes coinciding. While assembling holes in different components shall be made concentric with the use of drills before service bolts are fixed.

Welding if required shall be done as per standard practice and as approved by the Engineer-in-Charge.

All permanent machine fitted nuts and bolts must be perfectly tight and shall be burred or otherwise checked to prevent nuts from becoming loose. No unfitted rivet or bolt holes are to be left in any of the structure.

Structural Steel

All structural steel shall conform to IS:2062-1984. The steel shall be free the defects mentioned in IS given above and shall have a smooth finish. The material shall be free from loose mild scale, rust pits or other defects affecting the strength and directly.

General

Engineer's approval shall be obtained before commencing the painting work. All paints and preserves shall be of approved make and colour and their application shall conform to the manufacture's instructions. Where more than one undercoat is specified it shall be applied in coats of distinctive tints. Workmanship shall conform to the requirement of IS:2395

Unless the manufacturer's instructions state otherwise 48 hours drying time shall elapse between successive applications of any primer and 24 hours between applications of all subsequent coats. The surface of bituminous paints shall be left at least 3 days before further handling.

No paints in any coats shall be applied until the engineer is satisfied that the surface is clean and dry. And that any previous coat is satisfactory and has hardened adequately. When a surface has been approved, it must be painted immediately.

Paint work shall be rubbed down with a glass paper between coats. No paint shall be applied to a surface, which is damp, dirty or otherwise inadequately prepared.

Ironwork and Un Galvanized Steelwork

Structural steelwork shall be shot blasted to a "white metal" finish, and grease and oil removed prior to painting. Priming shall immediately follow blast cleaning and no cleaned surface shall be left unprimed for more than four hours. Only primers that chemically inhibit corrosion shall be used. Where the iron or steelwork is not in contact with raw or treated water, the primer shall be red lead complying with IS: 57. Where there is a possibility that the steel or ironwork may come in contact with water, the priming treatment shall be non toxic, zinc chromate or equivalent. Where it is anticipated that further welding will be required. an approved welding primer shall be applied to the areas to be welded and re primed with the main primer when welding has been completed. Primer coats shall not be less than 0.05 mm each.

After erection, all damaged areas shall be made good, and re primed where the original coat has spread under the primer, the affected surface shall be cleaned down to bare metal to the satisfaction of the Engineer and then re primed.

Repainting shall be carried out as soon as possible after erection. If it is to be exposed to weather or condensation, it shall receive one further coat of primer.

Metalwork in intermittent or permanent contact with raw or treated water shall have two finishing coats of an approved coal tar pitch epoxy paint such as "Epilux 5" by Berger Paints, or equivalent. The total coating shall be minimum of 0.125 mm thick.

After the second coat of primer is hard dry, the entire surface shall be wet rubbed cutting down to a smooth uniform surface. When the surface becomes dry, be undercoat of synthetic enamel paint conforming-to IS:2932 of optimum thickness shall be applied by

brushing with minimum of brush marks. The coat shall be allowed to hard dry. The under coat shall then be wet rubbed cutting down to a smooth finish, taking adequate care to ensure that at no place the undercoat is completely removed. The surface shall then be allowed to dry.

The first finishing coat of paint shall be applied by brushing and allowed to hard dry. The gloss from the entire surface shall then be gently removed and the surface dusted off. The second finishing coat shall then be applied by brushing.

At least 24 hours shall elapse between the applications of successive coats. Each coat shall very slightly in shade and this shall be got approved by the Engineer.

Brick Work and Stone Masonry

These specifications deal with all types of brickwork required for buildings, manholes, drains, retaining walls or any construction made out of bricks.

Relevant IS Codes

IS:1077	:	Common burnt clay building bricks
IS:2180	:	Heavy duty burnt clay-building bricks
IS:2212	:	C.P. for brickwork
IS:3495 (I – IV)	:	Method of test for clay building bricks
IS:5454	:	Method of sampling of clay building bricks

Materials

Bricks

Bricks used for the construction of brick masonry shall be sound, hard, rectangular in shape and size and well burnt of uniform deep red, cherry or copper colour and shall conform to IS:1077-1986.

The bricks shall be brought from approved brick kilns. The bricks shall be free from cracks, chippings flaws, stones or lumps of any kind. The bricks shall not show any signs of efflorescence and shall be homogeneous in texture.

They should emit a clear metallic sound on being struck and shall have a minimum compressive strength of 75 kg/sq.cm. They shall not absorb water more than specified in the Indian Standard Specifications, of its dry weight when soaked in cold water for 24 hours.

Mortar

The proportion of the cement mortar used for the masonry work shall be as specified on the various drawings for different places/types of construction, bills of quantities, specifications for each part of the work.

Mortar should be prepared by volume using boxes of appropriate sizes on clean platform or this sheet to avoid mixing of foreign material and maintain consistency of mortar.

Sharp coarse sand is mixed with the required quantity of cement for the preparation of the mortar. Mortar shall be prepared in accordance with IS:2250-1981. The sand used for the masonry mortar shall meet the requirements as specified in IS:2116-1980. Sand for masonry mortars. Sand and cement of required proportions are mixed in small quantities in a dry state first and then water is added to make the mortar of required the consistency suitable for the type of work it is required as directed by the Engineer-in-charge. No left over mortar shall be used and therefore only that much quantity of mortar that can be consumed within 30 minutes shall be mixed in batches.

Construction

The brick masonry shall be constructed as per the Indian Standard Code of Practice for Brick Work - IS: 2212-1962. The thickness of the joints shall not be thicker than those specified in of the above Code of Practice.

The bricks shall be thoroughly soaked in water before using them on the work for at least six hours and all the air bubbles shall come out during soaking process. The soaked bricks

shall be stacked on wooden planks/platforms so as to avoid sticking of the earth and other materials on to the surfaces of bricks. Bricks required for construction in mud mortar or lime mortar shall not be soaked. Brickwork shall be laid in English Bond unless otherwise specified. Half bricks shall not be used except when need to complete the bond. Each course shall be perfectly straight and horizontal. The masonry shall be true to plumb in case of vertical walls and in case of battered construction the batter or slope shall be truly maintained. The level of the courses completed shall be checked at every meter interval or less as required.

The bricks shall be laid frogs upwards. While laying the bricks they shall be thoroughly bedded and flushed in mortar and well trapped into position with wooden mallets and superfluous mortar shall be removed.

No part of the structure shall be raised more than one meter above than the rest of the work. In case it is unavoidable the brickwork shall be raked back at an angle of not more than 45 degrees so as to maintain a uniform and effectual bond, but raking shall not start within 60 cms from a corner.

In cases of construction of buttresses, counter forts, returns they are built course by course carefully bound into the main walls. At all junctions of walls the bricks at alternate courses, shall be carried into each of the respective walls so as to thoroughly unite both the walls together. The brickwork shall not be raised more than 14 courses per day.

All the beds and joints shall be normal to the pressures applied upon them i.e. horizontal in vertical walls, radial in arches and at right angles to the face in battered retaining walls.

Vertical joints in alternate courses shall come directly one over the other and shall be truly vertical. Care shall be taken to ensure that all the joints are fully filled up with mortar, well flushed up where no pointing is proposed, neatly struck as the work proceeds. The joints in faces, which are plastered or painted, shall be squarely raked out to a depth not less than 12 mm while the mortar is still green. The raked joints shall be well brushed to remove the loose particles and the surfaces shall be cleaned with a wire brush so as to remove any splashes of mortar sticking to the surfaces during the construction.

All iron fixtures, pipes, bolts, conduits, sleeves, holdfasts etc., which are required to built into the walls shall be embedded in cement mortar or cement concrete as shown in the drawings/indicated in the specifications directed during the execution by the Engineer-in-charge as the work proceeds and no holes be left for fixing them at a later date unless authorized by the Engineer-in-Charge.

Curing

Fresh work shall be protected from rain by covering the work suitably. Masonry work as it progresses shall be thoroughly kept wet by watering on all the faces for atleast 7 (Seven) days after completion of the parts of the work. Proper watering cans, flexible pipes, nozzles shall be used for the purpose. The top of the masonry work shall be kept flooded at the close of the day's work by constructing fillets of mortar 40 mm high all around the edges of the top course. In case of fat lime mortar curing shall start two days after construction of masonry and shall continue for seven days. No additional payment is admissible for curing and the rates quoted are deemed to be inclusive of the cost of curing.

Scaffolding

Double scaffolding sufficiently strong so as to withstand all loads that are likely to come upon it and having two sets of vertical supports shall be provided. Where two sets of vertical supports are not possible the inner end of the horizontal supporting pole shall rest in a hole provided in a header course only. Only one header for each pole shall be left cut. Such holes, however shall not be permitted in pillars under one meter in width or immediately near the skewbacks of arches. Such holes shall be filled up immediately after removal of the scaffoldings. Safety Code for Scaffolds and Ladders, IS:3696-1987 (Parts I and II) shall be followed. The cost of scaffolding is deemed to be included in the rates quoted for brick masonry and no separate costs are payable.

Stone Masonry for Retaining Walls

Stone masonry in general is to be used for retaining walls as per engineer in-charge's instructions and as per drawings, which will be supplied during course of construction to suit site conditions.

Following Indian Standards shall be applicable:

IS:1122-1974	Methods of determination of specific gravity and porosity of natural building stones
IS:1200	Method of measurement of stone masonry.
IS:1597	Code of practice of construction of rubble stone masonry.
IS:1805	Glossary of terms relating to stone quarrying and dressing
IS:4101	Stone facing
IS:1121	Determination of strength, properties of natural building stones

Uncoursed Stone Masonry

Uncoursed stone masonry shall be built in layers not exceeding 450 mm in height. No stone shall be less in breadth than 14 times its height and less in length than twice its height. Every stone whether large or small, shall be laid in its natural bed and set flush in mortar, and the small stones used for wedging or filling being carefully selected to fit the interstices between the large stones. Care shall be taken to see that no dry work or hollow space is left in the masonry. The stones shall be so arranged as to break joints at least every 80 mm and long vertical joints of joints shall be avoided. The joints at the face shall be finished off neatly, being struck and smoothed with a trowel while the mortar is fresh. The upper surface of the work shall be brought to a uniform level at the height of each course. The faces of masonry walls shall be kept in perfect plumb and where batter has to be given it shall, be uniform. The stones at all comers and junctions of walls shall be of large sizes and hammer dressed to the correct angle.

Each stone shall be thoroughly wetted before being used in the work. The masonry shall be kept thoroughly wet during the progress of the work, (care being taken to water it even on Sundays and Holidays, special labour being employed if so required for this purpose) until it becomes hard. As far as practicable, the whole of the masonry shall be raised in one uniform level and no part of the masonry shall be allowed to rise more than 1 metre above the rest to avoid unequal settlement. If raising one part of wall before the other becomes unavoidable the end of the raised portion shall be racked back in steps to prevent cracks developing at the junction of the old and new work. Care shall be taken to see that the sides of the wall are not built separately from the hearting, the faces and internal filling being done simultaneously. The stones shall overlap and cross each other as much as possible. No course shall be laid unless the previous course is perfectly set.

At least one header or through stone per square metre of wall face shall be built into the work. The headers or through stones shall be at least 0.05 m² in area at face and shall have at least 0.025 m² area at the back face. Where the thickness of the wall is more than 600 mm a series of through stones shall be laid through the work so as to form a tie from front to back, breaking joints or overlapping each other for at least 150 mm. No stone whose length is less than 600 mm shall be used in such work as a header.

All the through stones shall be marked inside and outside and the marks shall be retained until ordered by the Engineer to be removed. Sufficient number of headers shall be collected on site before commencing any masonry work. Where adequate sized through stones are not available in required quantities, the use of pre-cast plain concrete headers in M-20 mix may be permitted at the discretion of the Engineer. No extra payment will be made for the provision of substitute headers in concrete

Quoins shall be 150 mm high and formed of header stones at least 300 mm long. They shall be laid lengthwise alternately along each face and square on their beds, which shall be dressed to a depth of at least 80 mm.

Weep holes 80 mm wide and 150 mm in height shall be provided in retaining walls at the rate of one per square metre as specified or directed. They shall be pointed with 1:2 cement sand mortar after raking the joints to a minimum depth of 25 mm.

Completed masonry shall be kept wet for a minimum period of 14 days. In wet weather newly laid masonry shall be protected from the effects of heavy rainfall by tarpaulins or other approved material.

Pointing of Uncoursed Masonry

Joints in exposed masonry faces shall be formed while the mortar is still green and shall be finished as flush joints, weathered joints, round-recessed joints or square-recessed joints as directed by the Engineer. Masonry which is to be rendered or plastered shall have the joints raked out to a depth of 15 mm to form a key.

Stone Pitching

Stone pitching: to slopes shall be carried out where specified or as directed by the Engineer. Stone for pitching shall be obtained from an approved source and shall be hard, sound, durable, clean and generally as specified. The minimum dimension of any stone shall be, at least equal to the specified thickness of the pitching.

After excavation and trimming, slopes to be pitched shall be spread with a 75mm thick layer of crusher run rock or graded coarse aggregate ranging from 75mm particle size to fines. The slope shall then be hand packed with hard broken rock to a total thickness of 150 mm, each stone being individually placed and rammed home, with smaller stones edged into the cracks. 50mm dia weep-holes shall be provided where specified at intervals not exceeding two meter's in both directions. Joints in stone pitching shall be flushed up with sand/cement mortar on completion.

Rubble Packing

Rubble used for packing under floors, foundations, etc. shall be hard and durable rock, free from veins, flaws and other defects. The quality and size of the rubble shall be subject to the approval of the Engineer.

Rubble shall be hand packed as directed by the Engineer. They shall be laid closely in position on the sub-grade. All interstices between the stones shall be wedged in with smaller stones of suitable size well driven to ensure tight packing and complete filling of interstices. Such filling shall be carried out simultaneously with the placing in position of rubble stones and shall not lag behind.

Small interstices shall be filled with hard clean sand and well watered and rammed.

Concrete Block Masonry

Materials

Masonry units of hollow and solid concrete blocks shall conform to the requirements of IS : 2185 (Part I).

Masonry units of hollow and solid light-weight concrete blocks shall conform to the requirements of IS:2185(Part 3).

Masonry units of autoclaved cellular concrete blocks shall conform to the requirements of IS:2185(Part 3).

The height of the concrete masonry units shall not exceed either its length or six times its width.

The nominal dimensions of concrete block shall be as under.

Length 400, 500 or 600 mm

Height 100 or 200 mm

Width 100 to 300 mm in 50 mm increments

Half blocks shall be in lengths of 200, 250 or 300mm to correspond to the full-length blocks. Actual dimensions shall be 10mm short of the nominal dimensions.

The maximum variation in the length of the units shall not be more than 5 mm and maximum variation in height or width of the units shall not be more than 3mm.

Concrete blocks shall be either hollow blocks with open or closed cavities or solid blocks.

Concrete blocks shall be sound, free of cracks, chipping or other defects, which impair the strength or performance of the construction. Surface texture shall as specified. The faces of the units shall be flat and rectangular, opposite faces shall be parallel and all arises shall be square. The bedding surfaces shall be at right angles to the faces of the block.

The concrete mix for the hollow and solid concrete blocks/light weight concrete blocks shall not be richer than one part of cement to six parts of combined aggregates by volume.

Concrete blocks shall be of approved manufacture, which satisfy the limitations in the values of water absorption, drying shrinkage and moisture movement, as specified for the type of block as per relevant IS code. Contractor shall furnish the test certificates and also supply the samples for the approval of Engineer In Charge.

Workmanship

The type of the concrete block, thickness and grade based on the compressive strength for use in load bearing and/or non-load bearing walls shall be as specified. The minimum nominal thickness of nonload bearing internal walls shall be 100mm. The minimum nominal thickness of external panel walls in framed construction shall be 200 mm.

The workmanship shall generally conform to the requirements of IS:2572 for concrete block masonry, IS:6042 for light weight concrete block masonry and IS:6041 for autoclaved cellular concrete block masonry works.

From considerations of durability, generally concrete block masonry shall be used in superstructure works above the damp-proof course level.

Concrete blocks shall be embedded with a mortar, which is relatively weaker than the mix of the blocks in order to avoid the formation of cracks. Cement mortar of proportion 1:6 shall be used for the works.

The thickness of both horizontal and vertical joints shall be 10mm. The first course shall be laid with greater care, ensuring that it is properly aligned, leveled and plumb since this will facilitate in laying succeeding courses to obtain a straight and truly vertical wall. For the horizontal (bedding) joint, mortar shall be spread over the entire top surface of the block including front and rear shells as well as the webs to a uniform layer of 10mm. For vertical joints, the mortar shall be applied on the vertical edges of the front and rear shells of the blocks. The mortar may be applied either to the unit already placed on the wall or on the edges of the succeeding unit when it is standing vertically and then placing it horizontally, well pressed against the previously laid unit to produce a compacted vertical joint. In case of two cellblocks with slight depression on the vertical sides these shall also be filled up with mortar to secure greater lateral rigidity. To assure satisfactory bond, mortar shall not be spread too far ahead of actual laying of the block as the mortar will stiffen and lose its plasticity. Mortar while hardening shrinks slightly and thus pulls away from the edges of the block. The mortar shall be pressed against the units with a jointing tool after it has stiffened to effect intimate contact between the mortar and the unit to obtain a weather tight joint. The mortar shall be raked to a depth of 10mm as each course is laid to ensure good bond for the plaster.

Dimensional stability of hollow concrete blocks is greatly affected by variations of moisture content in the units. Only well dried blocks should be used for the construction. Blocks with moisture content more than 25% of maximum water absorption permissible shall not be used. The blocks should not be wetted before or during laying in the walls. Blocks should be laid dry except slightly moistening their surfaces on which mortar is to be applied to obviate absorption of water from the mortar.

As per the design requirements and to effectively control cracks in the masonry, RCC bound beam/studs, joint reinforcement shall be provided at suitable locations. Joint reinforcement shall be fabricated either from mild steel wires conforming to IS:280 or welded wire fabric/high strength deformed basis.

For jambs of doors, windows and openings, concrete blocks shall be provided. If hollow units are used, the hollows shall be filled with concrete of mix 1:3:6. Hold fasts of doors/windows should be arranged so that they occur at block course level.

At Intersection of walls, the courses shall laid up at the same time with a true masonry bond between atleast 50% of the concrete blocks.

Curing of the mortar joints shall be carried out for atleast 7 days. The walls should only be lightly moistened and shall not be allowed to become excessively wet.

Double scaffolding shall be adopted for execution of block masonry work.

Cutting of the units shall be restricted to a minimum. All horizontal and vertical dimensions shall be in respectively, adopting modular co-ordination for walls, opening locations for doors, windows etc.

Concrete blocks shall be stored at site suitably to avoid any contact with moisture from the ground and covered to protect against wetting.

Damp-Proof Course

Materials and Workmanship

Where specified, all the walls in a building shall be provided with damp-proof course cover plinth to prevent water from rising up the wall. The damp-proof course shall run without a break throughout the length of the wall even under the door or other openings. Damp-proof course shall consist of 50 mm thick cement concrete of 1:2:1 nominal mix with approved water-proofing compound admixture conforming to IS: 2645 in proportion as directed by the manufacturer. Concrete shall be with 10 mm down graded coarse aggregates.

If the surface of brickwork/stone masonry work shall be leveled and prepared before laying the cement concrete. Side shuttering shall be properly fixed to ensure that slurry does not leak through and is also not disturbed during compaction. The upper and side surface shall be made rough to afford key to the masonry above and to the plaster.

Damp-proof course shall be cured properly for at least seven days after which it shall be allowed to dry for taking up further work.

Plastering

Relevant IS Codes

IS:1542	:	Sand for plaster
IS:1661	:	C.P. for application of ferrous metals in building
IS:2394	:	C.P. for application of lime plaster finish

Plastering

Cement mortar used for plastering shall be of the mix proportions and thickness as specified on the drawings or bill of quantities or particular specifications for the various different parts of the works.

The materials used i.e. cement, sand and water shall be of the same quality and of the same specifications as indicated for plain and reinforced cement concrete works in the Section D2 of this tender.

Sand further shall meet the specifications as laid down in IS:1542-1977 Specification for sand for plaster.

The surfaces that are to be applied with plaster shall be thoroughly cleaned to remove dust, dirt, loose particles, oil, soil, slats etc. that may be sticking to the surfaces. The surfaces shall be washed clean and watered properly for 4 hours before applying plaster.

Plaster shall not, in any case, be thinner than specified. It shall have uniform specified thickness. When smooth finishing is required the cement plastering shall be floated over with neat cement within 15 minutes after application of the last coat of plastering.

The plaster shall be protected from the sun and rain by such means as the Engineer-in-charge in charge may approve. The plastered surfaces shall be cured for 7 (seven) days. Construction joints in plastering shall be kept at places approved by the Engineer-in-Charge. When the thickness of the plaster specified is to be made up in more than one layer, the second layer shall be applied only when the lower coat is still green. After applying the first layer the surface should be roughed and wherever specified, approved brands of additives like water proofing compounds shall be added in specified quantities as recommended by the manufacturer of the compound, or as directed by the Engineer-in-Charge.

Wherever scaffolds are necessary for plastering they shall be provided. Stage scaffolding shall be provided for ceiling plaster. To ensure even thickness and true surface, patches of plaster about 15 cms x 15 cms shall be first applied both horizontally as vertically 2 m apart. Plastering shall be done from top to bottom and care shall be taken to avoid joints on continuous surface.

Sand face plaster shall consist of first layer of 12 mm average thick cement plaster in cement mortar 1: 6 (One part cement and Six parts coarse sand). A second layer of 4 mm average thick in cement mortar 1:4 (one part cement and four part coarse sand) shall be applied. After the application of final coat, the surface shall be finished with the application of sponge rubber or as directed to obtain a uniform sand particle surface finish.

In case any other finish like rough cast finish or dry dash finish is specified in the drawings the same shall be provided as directed by the Engineer-in-Charge. Surfaces, which are to be plastered, shall be roughened while they are still green or raked so as to give proper bond between the surface and plaster.

All corner, edges, junctions shall be truly vertical or horizontal as the case may be and carefully finished. Rounding or chamfering of corners shall be carried out with proper templates to the required size and shapes.

No additional charges for works like scaffolding curing etc. are payable over and above the rates quoted for brickwork. The rates quoted shall be deemed to be inclusive of all such works.

Neeru

Material

Neeru shall be made of the best description of lime slaked with fresh water and sifted. The lime to be reduced to fine powder by grinding it on a stone or in a hand mill, with a thick solution of mussalla to be made or as may be desired by the engineer. The neeru thus prepared shall be kept moist until used and the quantity to be prepared at one time shall be such that it can be consumed in eight days.

Workmanship

All stone or brick masonry shall be thoroughly wetted and joints raked out to a depth of at least 20mm and walls washed before any plastering is done. The surface shall then rendered with fine sand, to the specified thickness and roughness. The surface shall then be floated or set with a thin coat, 3mm thick of cement and polished, well with a trowel or flat board. The cement mortar shall be used within 30 minutes after it leaves the mixing board or mill. Before any plasterwork is started patches of plaster 150mm x 150mm shall be put on at every 3 meters apart as gauges so as to ensure an even thickness throughout the work. Cement plaster shall be done in even square or strips. Care shall be taken to keep the whole surface thoroughly wetted for at least a week. The finishing surface shall be as specified and directed. If neeru finish is specified then the same shall be applied to the prepared and partially set but somewhat plastic surface with steel trowel to a thickness slightly exceeding 1.5 mm and rubbed down to 1.5mm thickness and polished to a perfectly smooth and even finish working from top to bottom. The surface shall be then colored, if required with 3 coats of white or colour wash for which no extra payment shall be made.

Flooring

Relevant IS Codes

IS:777	:	Glazed earthen ware tiles
IS:1237	:	Cement Concrete flooring tiles
IS:1443	:	C.P. for laying & finishing of cement concrete flooring tiles
IS:2114	:	C.P. for laying in-situ terrazzo floor finish

General

The materials and workmanship conform to the provisions of the following codes and standards. In particular and with such other standards as mentioned hereinafter. BIS: 269, 385, 515, 653, 712, 809, 1077, 1195, 1196, 1197, 1198, 1237, 1344, 1443.

Cement Concrete Flooring

General

Flooring shall consist of a sub-base laid on the compacted earth or sand fill as required, a base course laid on the sub-base and then a finishing layer of concrete, Terrazzo or any other material as specified to be laid. The materials for filling (Earth or sand as specified in drawings) shall be brought from the source as approved by the Engineer-in-Charge.

Filling

The surface to receive the filling shall be first cleared free of all roots, vegetation and wetted. Filling in plinth or other specified levels shall proceed in layers of 15 cm. Along with the construction of building, it shall be watered and well rammed in layers as mentioned above and compacted to the satisfaction of the Engineer-in-Charge.

Care shall be taken to remove all roots, vegetation, foreign matter, etc. from the earth used for filling. After thorough consolidation, required quantity of the filling corresponding to the thickness of floor shall be scrubbed to make space for the flooring.

Where sand filling is specified, the sand shall be clean, free from vegetation and other deleterious materials and same procedure followed as for earth filling. In case of sand filling, if required, flooding shall be done to achieve required compaction.

Preparation of Bed

The bed for flooring shall be prepared either level or sloped as per relevant drawings or as instructed by Engineer-in-Charge. Care shall be taken that there are no roots, vegetation, foreign matter, etc.

Sub-Base

On the prepared bed as indicated above, boulder, or gravel or broken bricks or sand or cement concrete (1:4:8 as per BIS: 465) shall be laid to thickness as specified. This layer shall be beaten with rammers until thoroughly consolidated. All the material used shall conform to the required specifications.

The materials proportion, mixing, laying, and curing, etc. for cement concrete shall be carried out as specified.

The finished work shall be of uniform depth over the whole floor with surface even and parallel to the prepared bed as per drawing or as directed by Engineer-in-Charge.

a. **Boulders as Sub-base Course**

Boulders shall be laid over the prepared bed as per general specification and shall be of size 100 to 150 mm and shall be of approved quality. Boulders being used shall

be free from decay, weathering and be stacked in such heaps in place as directed by Engineer-in-charge, the thickness being as specified in the relevant drawings.

b. **Sand Layer**

Sand for sand layer to be laid over the prepared bond shall be clean, free from admixture as per specification. Sand layer shall be spread in one or more layers to the thickness as indicated in drawings or schedule of item watered and rammed.

Base Course

Cement Concrete

It shall be of specified mix and shall generally conform to “Construction Specification for Cement Concrete”.

Panels

To prevent construction cracks, the floor space shall be divided into square or rectangular panels. The base course of specified thickness shall be laid in alternate panels or any other pattern as approved by Engineer-in-Charge. The panels shall be of uniform size, not exceeding 4.0 m. in any direction for a floor having thickness 40 mm and above. Alternate panels shall be laid on different days.

Construction joints shall be formed in between the sequential panels cast, with straight edges, 20 mm deep and 12 mm wide in groove form. These joints on completion of work, shall be cleaned and washed free of dust with the help of brush and shall be treated with hot bitumen poured in the gap, over which fine sand shall be spread to arrest the flow of bitumen.

Shuttering

The panels shall be bounded by glass strips having the same depth as the concrete floor. These shall be fixed in position with their top at proper level, giving slope. The floors shall butt against masonry of wall before it is plastered.

Concreting

Cement concrete shall be placed in position with or without MS reinforcements as shown in drawings and beaten with trowel and finished smooth or left rough as directed by the Engineer-in-Charge. Beating shall cease as soon as surface is found covered with cream of mortar. The surface shall be checked with the help of straight edge and made true.

The shuttering shall be removed next day. Care shall be taken to see that edges are not damaged and fresh mortar from adjacent panels is not splashed over them. The joints between panels shall come out as fine straight line.

MS reinforcement used for concrete base course with reinforcement shall conform to relevant BIS Specifications as detailed in drawings. Before placing of those reinforcements, they shall be cleared of scales with wire brush and oily stains removed.

Floor Finish Plain Cement Finish

Finishing of the surfaces shall follow immediately after the completion of base course. The surface shall be left for some time till the moisture disappears from it. Use of dry cement or cement and sand mixture sprinkled on the moisture shall not be permitted.

Fresh quantity of cement at 2.2 kg per square metre of flooring shall be mixed with water to form thick slurry and spread over the surface, while the concrete is still green. It shall be pressed twice by means of iron floats, once when the slurry is applied and second time when cement starts setting.

The junction of floor with wall plaster, clods or skirting shall be rounded off uniformly where so required upto 25 mm radius or as directed. The men engaged on finishing operations shall be provided with raised wooden platform to sit on, so as floor finish is specified, the top surface of floor finish shall be chequered with mesh or similar impression before the finish has set.

Curing

Each finished portion of floor, on completion, shall be kept wet with ponding or moist sand or moist gunny bags as per specifications. At no time, cement concrete layer, plain or reinforced shall be allowed to dry during curing time.

Granolithic (IPS) Flooring

The requirement for filling, preparation of bed, sub-base and base course concrete shall be same as in clauses above.

Finished Layers

Granolithic finish of the thickness as indicated in drawings or as specified shall consist of 2 layer of M15 grade cement concrete. The first layer of concrete shall be laid with 10 mm to 6 mm grade aggregate and well compacted. Within 15 minutes of laying this course the second layer with 6 mm down aggregate shall be laid. The cement and aggregates for the top layer shall be mixed dry.

Sufficient quantity of washed sand and water shall be mixed so as to make it plastic but not flowing. This mixture shall be laid on the first layer so that the two layers firmly grip together. The top layer shall be well tamped, spaded, trowelled and finished with neat cement slurry or with non-skid finish as required. At the junction of adjoining panels a thin string shall be given.

The casting of the granolithic finish layer shall be done in rectangular or square panels not exceeding 1.8 M on any side, using glass strips of height equal to the specified thickness of the floor finish. Required slope in the floor shall be given in the base course concrete without reduction in thickness.

Curing

Curing shall be done as per above mentioned clause.

Terrazzo (Mosaic) Tile

The tiles shall be approximately 22 mm thick of approved shade, color and chips. The tiles shall be pressure made conforming to IS:1237 in all respects. The sizes of the tiles shall be as given in table below:

Table 13 : Sizes of Terrazzo Tiles

Sr.	Nominal Length (cm)	Actual Length (cm)	Nominal Breadth (cm)	Actual Breadth (cm)	Thickness Not less than (mm)
------------	----------------------------	---------------------------	-----------------------------	----------------------------	-------------------------------------

Sr.	Nominal Length (cm)	Actual Length (cm)	Nominal Breadth (cm)	Actual Breadth (cm)	Thickness Not less than (mm)
1	20	19.85	20	19.85	20
2	25	24.85	25	24.85	22
3	30	29.85	30	29.85	25

Tolerances

Tolerances on length and breadth shall be ± 1 mm. Tolerance on thickness shall be ± 5 mm. The range of dimension in any one direction of tiles shall not exceed 1 mm on length and breadth and 3 mm on thickness.

Manufacture

The tiles shall be manufactured under hydraulic pressure of not less than 140 kg/cm^2 and shall be given the first grinding with machine before delivery to the site. The proportion of cement to aggregate in the backing of the tiles shall not be leaner than 1:3 by weight. Similarly the proportion of cement to marble chips aggregate in the wearing layer of the tiles and the proportion of pigment to be used therein shall not exceed 10% by weight of cement used in the mix. The finished thickness of the upper layer shall not be less than 5 mm for size of marble chips from the smallest upto 6 mm, and also, not less than 5 mm for size of marble chips ranging from the smallest upto 12 mm, and not less than 6 mm for sizes of marble chips varying from the smallest upto 20 mm.

Laying

The sub-grade concrete or the R.C.C slab on which the tiles are to be laid shall be cleaned, wetted and mopped. The bedding for the tiles shall be with lime mortar of either:

- i. 1:1:2 (lime putty:surkhi :coarse sand)
- ii. 1:3 (lime putty :surkhi)
- iii. 1:3 (lime putty : coarse sand)

The bedding ingredients shall be thoroughly mixed by volume in the dry form. Care shall be taken to ensure that there are no hard lumps present. Water shall then be added and the ingredients thoroughly mixed. The average thickness of the bedding mortar shall be 30 mm.

Lime mortar bedding shall be spread, tamed and corrected to proper levels and allowed to be hardened for a day before the tiles are set. Over this bedding, neat grey cement slurry of honey like consistency shall be spread at the rate of 44 kg of cement per sq.m. over such an area as would accommodate about twenty tiles. Tiles shall be washed clean and shall be fixed in this grout one after another each tile being gently tapped with a wooden mallet till it is properly bedded and in level with the adjoining tiles. The joints shall be kept as thin as possible not exceeding 1.5 mm and in straight lines or to suit the required pattern.

The surface of the flooring during laying shall be the frequently checked with a straight edge atleast 2 m long, so as to obtain a true surface with the specified slope. In situations where full size tiles cannot be fixed, these shall be cut (sawn) to the required size and their edge rubbed smooth to ensure a straight and true joint. Tiles, which are fixed in the floor adjoining the wall, shall enter not less than 12 mm under the plaster, skirting or dado. The junction between the wall plaster and tile work shall be finished neatly and without any waviness. After laying the tiles, the surplus cement grout shall be cleaned off.

Curing, Polishing and Finishing

After laying the tiles the day after all the joints shall be cleaned of the grey cement grout with a wire brush or trowed to a depth of 5 mm and all dust and loose mortar removed and cleaned. Joints shall then be grouted with grey or white cement mixed with or without pigment to match the shade of the topping of the wearing layer of the tiles. The same cement slurry shall be applied to the entire surface of the tiles in a thin coat for protecting the surface from abrasive damage and fill the pin holes that may exist on the surface.

The floor shall then be kept wet for a minimum period of 7 days. The surface shall thereafter be grounded evenly with machine fitted with coarse grade grit blocks No.60. Water shall be used profusely during grinding. The surface shall be washed thoroughly with water to remove all grinding mud, cleaned and mopped. Then it shall be corrected with a thin coat of grey or white cement, mixed with or without pigment to match the colour of the topping of the wearing surface in order to fill any pin hole that appear. The surface shall be again cured; the second grinding shall then be carried out with machine fitted with fine grade grit blocks No. 120.

The final grinding shall be carried out with the machine fitted with finest grade grit blocks No. 320, the same day after the second grinding described above.

The small areas or where circumstances so required hand polishing may be permitted in lieu of machine polishing after laying. For hand polishing coarse grade stone No. 60 Water shall be used for 1st rubbing stone of medium grade No.80 for second rubbing and stone of fine grade No.120 for final rubbing and polishing.

After the final polish oxalic acid shall be dusted over the surface of 33 gm/sq.m sprinkled with water and rubbed hard with a 'namdah' block (pad or woolen rags). The following day the floor shall be wiped with a moist rag and dried with a soft cloth and finished clean.

If any tile is disturbed or damaged, it shall be refitted or replaced, properly jointed and polished. The finished floor shall not sound hollow when tapped with a wooden mallet.

Terrazzo (Mosaic) In-Situ Flooring

The requirements for filling, preparation of bed, sub- base and base course concrete shall be same as above.

Trained worker shall carry out terrazzo works.

Material

Best quality marble chips of uniform tint and color, 6 mm maximum and 3 mm minimum size, as approved by Engineer-in-Charge shall be used. They shall be machine crushed, free from foreign matter and of approved quality.

Preparation of Surface and Laying Over Base Course Concrete

Total thickness of cast-in-situ Terrazzo shall be atleast 40 mm unless otherwise indicated. This shall be in two layers bottom layer of M:15 concrete bedding with 10 mm down aggregate of specified thickness and the top layer of 10 mm thickness, consisting of a mix of cement and marble chips in the proportion of 1:1/2 marble powder : 2 marble chips). The bottom layer shall be laid in bays not exceeding 1.2 m on either side and leveled 10 mm below the finished floor level.

The cement and marble chips including powder shall be mixed dry. Water shall be added gradually after through mixing until the mix become plastic but flowing.

Within one hour of laying of the bottom layer of cement concrete the upper layer of marble chips and cement paste shall be laid over a coat of cement slurry and the surface tamped lightly and finished to the required level and slope.

While the bottom layer is still plastic glass dividing strips 35 mm wide x 16 SWG thick shall be fixed on the base course concrete with proper anchoring features to allow top edge to be flushed with the finished floor. The strip shall be laid, forming panels not exceeding 1.2 m x 1.2 m size.

Curing, Polishing and Finishing

The floor shall then be kept wet for a minimum period of six days. The surface shall thereafter be ground evenly to the satisfaction of the Engineer-in-charge with machine grinders in three phase with grade stones from coarse to fine grade. The surface shall receive wash of neat cement mixed with or without pigment and cured before every grinding operation.

After final grinding, surface shall be cleaned and oxalic acid shall be dusted over the surface @ 35 grams. per sq.m. Sprinkled.

Glazed Tile Flooring

White Glazed Tiles

The glazed tiles shall conform to IS:777-1970. They shall be flat and true to shape and free from cracks, crazing spots, chipped edges and corners. The glazing shall be of uniform shade.

Size and Tolerance

The tiles shall be of nominal sizes such as 150 x 150 mm and 100 x 100 mm or as specified. The thickness of the tiles shall be 5 mm, or 6 mm as specified. The tolerance on facial dimension value shall be ± 1.0 mm and ± 0.5 mm on thickness.

The top surface of the tiles shall be glazed. The glaze shall be either glossy or matt as specified. The underside of the tiles shall be completely free from glaze in order that the tiles may adhere properly to the base. The edge of the tiles shall be preferably free from glaze, however any glaze if unavoidable, shall be permissible on any one edge of the tile.

Coloured Tiles

The sizes and specifications shall be the same as for the white glazed tiles described above. The only difference shall be in the colour.

Decorative Tiles

The type and size of the decorative tiles shall be as follows:

Decorated white background tiles shall be of 152 x 152 x 6 mm and 108 x 108 x 6 mm sizes.

Decorated and having coloured background shall be of 152 x 152 x 6 mm and 108 x 108 x 6 mm sizes.

Fantasy glazed tiles (108 x 108 x 6 mm) other specifications will be the same as that of white glazed tiles.

Preparation of Surface and Laying

Sub grade concrete or the R.C.C slab on which the tiles are to be laid shall be cleaned, wetted and mopped. The bedding for the tile shall be with 1:3 (cement: coarse sand) mortar or as specified, having average 10 mm thickness. The bedding thickness under the tiles shall not be less than 5 mm.

The mortar shall be spread, tamped and corrected to proper levels and allowed to harden sufficiently to offer a fairly rigid cushion for the tiles to be set and to enable the mason to place wooden plank across and square on it. Over this mortar bedding neat grey cement slurry of honey - like consistency shall be spread at the rate of 3.3 kg of cement per sq. m over such an area as would accommodate about twenty tiles. Tiles shall be soaked in water washed clean and shall be fixed in this grout one after another each tile gently being tapped with a wooden mallet till it is properly bedded and in level with the adjoining tiles. The joints in between the tiles shall be kept as thin as possible and in straight lines or to suit the required pattern.

The surface or the flooring during laying shall be frequently checked with a straight edge about 2 m long, for obtaining a true surface with the specified slope. Where full size tiles cannot be fixed these shall be cut (sawn) to the required size and their edge rubbed smooth to ensure straight and true joints. The tiles, which are fixed in the floor adjoining the wall, shall enter not less than 10 mm under the plaster, skirting or dado. After laying the tiles the surplus cement grout shall be cleaned off.

Pointing and Finishing

The joints shall be cleaned off the grey cement grout with wire brush or trowel to a depth of 2 mm to 3 mm and all dust and loose mortar removed. Joints shall then be flush pointed with white cement added with pigment if required to match the colour of the tiles. The floor shall then be kept wet for 7 days. After curing, the surface shall be washed and cleaned. The finish floor shall not sound hollow when tapped with a wooden mallet.

Kota Stone Flooring

Kota Stone Slabs- shall be of selected quality hard, sound, dense and homogeneous in texture, free from cracks, decay, weathering and flaws. They shall be hand or machine cut to the requisite thickness and shall be of the colour indicated in the drawings or as directed.

The top (exposed) face of the slabs shall be polished before being brought to site, unless otherwise specified. The slabs shall conform to the size required and samples shall be got approved before starting the work. 20, 30 or 40 mm or specified thickness slabs shall be used.

Tolerances

Of ± 2 mm shall be allowed for the thickness. In respect of length and breadth of slabs, a tolerance of ± 5 mm shall be allowed.

Dressing

Each slab shall be cut to the required size and shape and fine chisel dressed on the sides to the full depth, so that a straight edge laid along the side of the stone shall be in full contact with it. The sides (edges) shall be table rubbed with coarse sand or machine rubbed before paving. All angles and edges of the tiles shall be true, square and free from chipping and the surface shall be true and plane.

Surface Preparation and Laying

Sub-grade concrete on the R.C.C slab on which the slabs are to be laid shall be cleaned, wetted and mopped. The bedding for the slabs shall be with cement mortar 1:4 or with lime

mortar 1:1:1 (lime putty: surkhi : coarse sand) as given in the description of item. The average thickness of the bedding mortar under the slab shall be 20 mm and the thickness at any place under the slab not be less than 12 mm.

Mortar of the specified mix shall be spread under the area of each slab, roughly to the average thickness as specified. The slab shall be washed clean before laying. It shall be laid on top, pressed, tapped with wooden mallet and brought to level with the adjoining slabs. It shall be lifted and laid aside. The top surface of the mortar shall then be corrected by adding fresh mortar at hollows. The mortar is allowed to harden a bit and cement slurry of honey-like consistency shall be spread over the same at the rate of 4.4 kg of cement per sq.m. The edge of the slab already paved shall be buttered with grey or white cement with or without admixture of pigment to match the shade of the kota stone slabs as given or specified. The slab to be paved shall then be lowered gently back in position and tapped with wooden mallet till it is properly bedded in level with and close to the adjoining slabs with as fine joint as possible. All the subsequent slabs shall be laid in the same manner. After each slab has been laid, surplus cement on the surface shall be cleaned off. The flooring shall be cured for at least 7 days.

Slabs, which are fixed in the floor adjoining the wall, shall enter at least 12 mm under the plaster skirting or dado. The junction between wall plaster and floor shall be finished neatly and without any wavings.

Polishing and Finishing

Shall be done as described in the above article of 'Terrazzo Tile Flooring' except that:

First polishing with coarse grade carborundum stone shall not be done.

Cement slurry with or without pigment shall not be applied on the surface before polishing.

Mosaic Finished Dado or Skirting

For skirting and dado the brickwork or concrete surface shall be raked and shall be well watered for four hours. A dubbing coat of cement mortar 1:3 (1 cement: 3 sand) of sufficient thickness shall be applied so as to bring the surface in line with the plastered surface. The surface shall be carried by lines with trowel so as to receive mosaic tiles or the top layer or cement and marble chips in proportion of 1:1/2:2 (1 cement: 1/2 marble powder: 2 marble chips) of 7 mm thickness with 3-5 mm size for flooring including dividing strips (20 mm x 15 SWG) @ 600 mm c/c.

Hardonite Flooring

These specifications cover the guidelines for providing hardonite topping (industrial flooring) for floor subjected to heavy wear and tear viz., workshop and stores, engine room, and Generator room etc.

The item includes providing hardonite topping as specified to the thickness and satisfaction of the Engineer-in-Charge, supply of all material, labour, tools and plant required for completing the work in best workmanlike manner.

Workmanship

The person executing the topping shall be an experienced mason familiar with flooring works of similar nature. Flooring shall be laid uniformly, the tolerance for variation of level being + 3 mm.

Hardonite material shall be mixed with cement concrete thoroughly to give a uniform mix.

Preparation of Surface

Hardonite shall be laid over a wet concrete surface screened to receive the topping. The base shall be leveled to within + 12 mm.

Preparation of Topping

Hardonite shall consist of a mixture of cement concrete in proportion of 1:2:4 and well graded iron fillings added in a proportion of 1.50 kg/bag of cement.

Application

Hardonite shall be placed uniformly in a layer of specified thickness and finished with a steel trowel. Care shall be taken to place hardonite in a separate layer while the base concrete is still wet.

Trowelling

Surface of floor shall be finished with steel trowel only and trowelled just sufficient so as to give a finished surface. The surface shall be left for some time till moisture disappears from it. Trowelling shall be done three times at intervals so as to produce a uniform hard surface in no case cement should come up to the surface.

Curing

The entire surface shall be kept uniformly wet for seven days.

Opening for use

The surface shall be allowed to be used only after curing period is over.

Distempering and Painting

General

Engineer's approval shall be obtained before commencing the painting work. All paints and preservatives shall be of approved make and colour and their application shall conform to the manufacturer's instructions. Where more than one undercoat is specified it shall be applied in coats of distinctive tints. Workmanship shall conform to the requirement of IS:2395

Unless the manufacturer's instructions state otherwise 48 hours drying time shall elapse between successive applications of any primer and 24 hours between applications of all subsequent coats. The surface of bituminous paints shall be left at least 3 days before further handling.

No paints in any coats shall be applied until the engineer is satisfied that the surface is clean and dry. And that any previous coat is satisfactory and has hardened adequately. When a surface has been approved, it must be painted immediately.

Paint work shall be rubbed down with a glass paper between coats. No paint shall be applied to a surface, which is damp, dirty or otherwise inadequately prepared.

Concrete, brickwork and plaster

Where specified to be painted, concrete and plaster shall be rubbed smooth and any cracks, blister holes and other imperfections cut out, filled and made good. The surface shall be dried to the satisfaction of the engineer before painting is commenced and drying time if at least 28 days shall be allowed after laying brickwork and plaster or stripping formwork from concrete. The surface shall be brushed to remove any efflorescence and then painted with the following:

for interior brick work and concrete, apply two coats of oil paint up to 1 meter height and for remaining part two coats of plastic emulsion paint over a coat of primer.

For exterior brickwork and concrete, apply two coats of cement based paint over a coat of primer with a water repellent coat of silicate solution of approved make.

Where painting with plastic emulsion is specified, all uneven surface shall be made up by use of putty of appropriate quality, after the surface has been thoroughly cleaned of all dust and dirt and sand papered.

Ironwork and Ungalvanised Steelwork

Structural steelwork shall be shot blasted to a "white metal" finish, and grease and oil removed prior to painting. Priming shall immediately follow blast cleaning and no cleaned surface shall be left unprimed for more than four hours. Only primers that chemically inhibit corrosion shall be used. Where the iron or steelwork is not in contact with raw or treated water, the primer shall be red lead complying with IS: 57. Where there is a possibility that the steel or ironwork may come in contact with water, the priming treatment shall be non toxic, zinc chromate or equivalent. Where it is anticipated that further welding will be required, an approved welding primer shall be applied to the areas to be welded and re primed with the main primer when welding has been completed. Primer coats shall not be less than 0.05 mm each.

After erection, all damaged areas shall be made good, and re primed where the original coat has spread under the primer, the affected surface shall be cleaned down to bare metal to the satisfaction of the Engineer and then re primed.

Repainting shall be carried out as soon as possible after erection. If it is to be exposed to weather or condensation, it shall receive one further coat of primer.

Metalwork in intermittent or permanent contact with raw or treated water shall have two finishing coats of an approved coal tar pitch epoxy paint such as "Epilux 5" by Berger Paints, or equivalent. The total coating shall be minimum of 0.125 mm thick.

After the second coat of primer is hard dry, the entire surface shall be wet rubbed cutting down to a smooth uniform surface. When the surface becomes dry, an undercoat of synthetic enamel paint conforming to IS:2932 of optimum thickness shall be applied by brushing with minimum of brush marks. The coat shall be allowed to hard dry. The undercoat shall then be wet rubbed cutting down to a smooth finish, taking adequate care to ensure that at no place the undercoat is completely removed. The surface shall then be allowed to dry.

The first finishing coat of paint shall be applied by brushing and allowed to hard dry. The gloss from the entire surface shall then be gently removed and the surface dusted off. The second finishing coat shall then be applied by brushing.

At least 24 hours shall elapse between the application of successive coats. Each coat shall vary slightly in shade and this shall be got approved by the Engineer.

Galvanized Steelwork

Newly galvanised steelwork shall be primed with an etch primer such as calcium plumbate. Steelwork that has been galvanised for a long period so that the surface has oxidised adequately to allow adhesion of under-coats, need not have an initial coat of each primer.

After priming, galvanised steelwork in constant or intermittent contact with raw or treated water shall be given two coats of an approved coat of tar pitch epoxy paint such as "Epilux 5" by Berger Paints, or equivalent. The total coating shall have a minimum thickness of 0.125 mm.

Protective coats for galvanised steelwork not in contact with water shall be:

One coat of micaceous iron oxide paint for interior galvanised steel work.

Two coats of micaceous iron oxide paint for external galvanised steelwork.

Galvanised steelwork not in contact with water shall be finished with at least one coat of gloss paint on top of an approved undercoat.

Bituminous Surfaces

Metalwork items that have been given a shop treatment of bituminous paint shall be painted with two coats of an approved anti-bleed paint before applying a coat of decorative finishing paint.

Aluminum Surfaces

Aluminum surfaces shall be worked clean, dried and thoroughly degreased before painting, by an appropriate solvent (such as one consisting of equal parts of white spirit and light solvent naphtha). Flame cleaning shall not be permitted. The clean degreased surface shall be treated to ensure paint adhesion either by mechanical roughening, chemical adhesion, or

etch primers or wash primers applied in strict conformity with the manufacturer's instructions or by other treatment approved by the Engineer.

The pretreated surface shall receive a priming coat with an inhibiting pigment containing not less than 20% by weight of fine chromate or other approved chromate in a suitable water-resisting vehicle.

The priming coat shall not contain any copper or mercury compounds and it shall also be free from graphite and carbonaceous materials and shall not contain any lead. Priming coat shall consist of a tung-oil phenolicresin which is pigmented with equal parts of zinc tetroxy chromate and red iron oxide.

Aluminum surfaces in contact with concrete, or resting on pads on concrete, shall be painted with two coats bituminous paint, and the concrete surfaces shall also receive two coats bituminous paint.

Woodwork

Woodwork for painting shall be carefully rubbed down, treated with preservatives and knotted, stopped and primed in the shop. Care shall be taken to ensure that priming is thoroughly brushed into every part of the surface and in particular at end grains, joint and notches where two coats are to be applied. Primers for wood shall be of a standard equivalent to, or better than "Aluminum Wood Primer Sealer A519-3697" by I.C.I. Paints.

After the woodwork has been fitted and all defects in the surfaces have been made good and re primed, one coat of approved undercoat shall be applied to internal surfaces and two coats to external surfaces. An undercoat of quality equal to or better than "Delux Undercoat A522 line" shall be used.

Timber work shall be decoratively finished with one coat of finishing paint of standard equal to, or better than "Delux Gloss Finish A365 line".

Waterproof Cement Paint

Surface Preparation

The wall should be washed thoroughly with clean soft water and freed of all loose particles, dust, dirt, lichen, moss, efflorescence and Lime wash by Scrubbing with a wire brush. Inequality and holes shall be filled up with cement paste, which should be allowed to set. To get even uniform mat finish it is necessary to keep the surface damp throughout the operation. In hot dry weather the wall should be frequently sprinkled with water to keep it moist.

Mixing the paint

Loosen the contents by either rolling the drum or shaking the container before opening it. Take one measure of water by volume in a clean pot and add two volumes of approved quality waterproof cement paint conforming to IS: 5410. Stir well to make a paste of high consistency then add one more measure of water constantly stirring the mixture. The final composition of water and paint is now 1:1 by volume. Keep stirring the mixture all the time and use it up within an hour. Do not use the mix if it is left over for more than two hours.

Method of Application

Wet the surface by any convenient method. A small surface can be wetted by brush. When applying paint surface should be damp and not wet. While applying the first coat brush hard into the surface to cover pores and cavities to ensure better bond. Twelve hours after

applying the first coat cure the surface by sprinkling the water. Before applying the second coat damp the surface and after the application of second coat cure it as directed above. In hot climate repeat curing at least twice at the interval of six hours for optimum best results.

Curing

After sprinkling fine spray of water should cure each application paint normally after twelve hours when paint film is hardened satisfactorily. In summer when weather is hot, curing may be done little earlier. Water marks may be left over the surface if a stream of water is allowed to flow before the paint film is hardened.

Silicon Paint

Preparation

A solution for application shall be prepared from Syltrit 1772 or equivalent. The Manufacturer's instructions shall be followed. This solution shall be prepared to a concentration of about 3 % solids by mixing 1 kg. of water dilatable solution of sodium methyl silicate with 9 kg. of water. Concentration higher than 3% solids are not recommended as they may cause a white precipitate of sodium carbonate formation.

Application

A flooding technique should be used in applying to obtain the best penetration. When spraying, the solution should not be atomized or misted, but flowed on in a solid stream, with the spray gun held, at a distance just enough to eliminate foaming on the masonry surface. If foaming is allowed then certain visible marks might appear after application. The run down of 150 to 300 mm should be maintained with generous overlapping of passes. Dipping and brushing methods are also suitable. After application of the solution, the treated surface should be allowed to dry at least 24 hours to develop maximum water repellency. This interval may be shortened somewhat by force drying at temperatures to 30 degree C. Though this removes the water quickly, time must still be allowed for the curing. Reaction between the solution and the surface being treated. Until the reaction is complete the applied film still remains water soluble and any rain falling during this time can wash it out. So application should be done in dry weather or at least in absence of rain and fog.

Spraying Equipment

Spraying equipment shall be hand operated stirrup pump with stainless steel nozzle fitted with PVC or polyethylene delivery pipe. Components of the spraying, equipment that are in contact with the treating solution should be of black iron, mild steel, stainless steel, Teflon, PVC or polyethylene. They should not be of aluminum or galvanised steel. .

Safety

The solution should always be applied in a liquid stream, not by misting or fogging. If misting occurs, avoid inhalation. Contact with the eyes or skin should be treated immediately by flooding the area with large quantities of water for at least 15 minutes.

Relevant IS Codes

IS:63	:	Whiting for paints
IS:133	:	Enamel, interior, undercoating & finishing colour as required
IS:2395	:	C.P. for painting concrete, masonry & plaster surfaces
IS:5410	:	Cement paint, colour as required
IS:5411	:	Plastic emulsion paint for interior use

Distempering

Type

Distempering shall be of the oil or water bound type as specified.

Material

Dry distemper or oil bound washable distemper of approved brand and manufacture for water bound and oil bound respectively conforming to IS:426 shall be used. The proportions of the mix shall be as per the approved manufacturer's instructions.

The dry distemper shall be stirred slowly in clean warm water using 8.6 liters of water per kg. of distemper or as specified by the approved makers. The mixture shall be well stirred before and during use to maintain an even consistency.

Thinner as stipulated by approved manufacturer shall be used in case of distemper for oil bound type.

Dry distemper shall not be mixed in larger quantity than is actually required for one day work.

Preparation of Surface and Priming Coat

The surface shall be thoroughly brushed free from mortar dropping and other foreign matter and sand papered smooth.

A priming coat of whiting shall be applied over the prepared surface in case of water bound distemping and distemper primer or cement primer shall be applied in the case of oil bound distemper. The white washing coat shall be used as priming coat for distemper.

Application

After the primer coat is dried for atleast four hours, the entire surface shall be coated uniformly with proper distemper brushed in horizontal strokes, immediately followed by vertical ones which together shall constitute one coat.

Subsequent coats shall be applied in the same way and only after the previous coat has dried. Enough distemper shall be mixed to finish one room at a time. The finished surface shall be even and uniform and shall no brush marks. After each days work, the brushes shall be washed in hot water and hung down to dry. Old brushes, which are dirty or caked with distemper, shall not be used.

Decorative Finish Cement Paint

Surface Preparation

Plastered surface shall be thoroughly cleaned of dust, dirt, grease, oil marks, etc. before the coat is applied. All the holes and depressions should be filled with gypsum prior to application of the paint. The surface shall be wet with clean water before paint is applied. Application of primer shall be as per specifications recommended by approved manufacturer and as directed by the Engineer-in-charge.

Preparation of Mix and Application

Any approved cement paint shall be mixed in such quantities as can be used up within an hour of mixing. The solution shall be applied on the prepared surface with good quality brushes and no brush mark shall be visible on the finish work.

Painting

Painting General

Paints, oils, varnishes etc. of approved brand and manufacture conforming to relevant Indian Standard Codes shall be used. Ready mixed paints as received from approved manufacturer without any admixture shall be used. The contractor shall obtain permission for the make and color of the paint he proposes to use and if required, polish for wood work shall be tested as per IS:5807 (parts I and II).

Whenever thinning is necessary, the brand of thinner recommended by approved manufacturer or as instructed by Engineer-in-charge shall be used. Paints, oil, varnishes, thinner, etc. shall be brought to the site in the original containers in sealed condition and shall be kept in the joint custody of contractor and Engineer-in-Charge.

Commencing the Work

Painting except priming coat shall generally be taken in hand after all other building work is practically finished. Approval of Engineer-in-Charge shall be sought before commencing the work.

Workmanship

All the work shall be carried out wherever applicable as per IS:1477 (Parts I & II) and IS:2338 (Part I)

Preparation of Surface

The surface shall be thoroughly cleaned. All dirt, dust, scales and grease shall be removed before painting is started. The surface shall be perfectly dry to permit good absorption. The prepared surface shall receive approval from Engineer-in-Charge for commencing the painting work. For wood surfaces, a priming coat without coloring material should be applied after which all the holes, cracks etc shall be stopped with putty and all knots properly killed with quick lime.

Specially for wood surface, knots if visible shall be covered with red lead conforming to BIS:103. Holes and identification on the surface shall be filled with wood putty and rubbed smooth. Surface should be thoroughly dry.

Application

Paint shall be thoroughly stirred in the container when pouring into smaller containers for use. It shall be continuously stirred while applying on the surface. The painting shall be applied evenly and smoothly in the direction of grains of wood and perpendicular to it. Each coat shall be allowed to dry before the next coat is applied.

Specified number of coats shall be applied and at least 24 hours shall elapse between application of the first coat and the subsequent second coat. No painting shall be carried out on exterior work in wet weather condition or on surface which are not entirely dry. Each coat shall be lightly rubbed down with sandpaper or fine pumice stone and cleaned of dust before the next coat is laid. No left over paint shall be put back into stock tins.

The finished surface shall be free from hair or brush marks, strokes, clogging of paint puddles in the corners of panels, angles of moulding, etc.

Painting with Synthetic Enamel/Enamel Paint

Material

Synthetic enamel/enamel paint of approved brand and manufacture and of required shade shall be used for the topcoat only. The paint for under coat shall be of shade to match the topcoat, as recommended by approved manufacturer shall be used.

Preparation of Surface

The surface shall be thoroughly cleaned. All dirt, scales and grease shall be removed before painting started. The surface shall be perfectly dry to permit good absorption. The prepared surface shall receive approval from Engineer-in-Charge for commencing the painting work.

Specially for wood surfaces, knots if visible shall be covered with red lead conforming to IS:103. Holes and indentation on the surface shall be filled with good putty and rubbed smooth. Surface should be thoroughly dry.

Application

Under Coat

One coat of the specified paint of shade matching with the shade of the top coat shall be applied and allowed to dry overnight. It shall be rubbed next day with the finest grade of wet abrasive paper to ensure smooth and even surface, free from brush marks and all loose particles dusted off.

Top Coat

Top coats of specified paint in the desired shade shall be applied after the under coat is thoroughly dried. Additional finishing coat shall be applied if found necessary to ensure a properly uniform glossy surface.

Expansion Joints and Construction Joints

General

The item of providing expansion joints and construction joints in concrete includes all the material, labour, tools and plants necessary for completing the item in best workmanlike manner.

Material

The Material to be used in the joints shall be ribbed PVC water stop of specified width approved by the Engineer, bitumen impregnated fibre board as filler conforming to IS:10566 and approved sealant material (In case of movement joint only). In addition, IS:12220-1987 and 1838 shall also be adhered.

Joints in Floor

Joints in floor shall be provided as specified on drawings. In case of PVC water stops to be provided horizontal position flat-footed PVC water stops shall be used. The water stops shall be provided in such a way that half the portion of water stop (width wise) is embedded in the concrete and half remains exposed for next concrete. Steel reinforcement shall not be discontinued where construction joints in floor are provided.

Joints in Walls

Expansion Joint

Expansion joints shall be provided in the roof slab and wall and divide wall is of R.C.C. The joints shall be so located that in no case the slab shall be more than 45 metres long in one stretch. The general layout of roof slab showing the position of expansion joint is given in the accompanying drawing. The two adjoining portions of the roof slab at the expansion joints shall be separated by a gap of about 25 mm width which shall be bridged by means of 230 mm wide water stop. These water stops shall be fixed in such a manner that it is equally embeded in each portion of the slab on either side of the joint and shall be located at mid section of the slab. The joint shall be continuous in length and shall be properly joined together or welded at all junction along its length. The gap between the adjacent slab below the water stops shall be filled with filler material like thermocol or such compound which may be approved by the Engineer.

This may be achieved by placing a strip of filler material in position adjacent to the face of concreted slab panel while concreting the adjoining panel. The space above, water stop shall be filled with sealant material overlaid by filler material like thermocol and polysulphide sealant as shown in the drawing.

The expansion joints in the end wall and divide wall shall be provided in such a manner that the joint shall divide the structure longitudinally and transversely as shown in the drawing. The two adjacent parts of the wall shall be separated by a gap of about 25 mm width which shall be bridged by 300 mm wide PVC water stop. However, no gap shall be provided in the footing of the wall. The gap on water face shall be treated with polysulphide sealant material as shown in the drawing. The water stops shall be either PVC or either equivalent approved by the Engineer as per specifications given hereinafter.

Construction Joint

The construction joints shall be generally provided at the end of the concreting or colcreting operation of an element or a member of a structure, or at boundary of the panels or segments or at pre-determined locations. The construction joints in the R.C.C. slab shall be characterised by the continuance of the reinforcing steel, being a structural R.C.C. member.

The concreting of a slab at the joint shall be done by laying the concrete against the vertical stopping off boards, the adjoining panels being cast butting against each other.

Construction joints in the side wall and the divide wall of reservoir shall be of two types (i) horizontal construction joints and (ii) vertical construction joints.

The horizontal construction joints shall be serrated type where stones from the lower lift of the wall shall be projecting out sufficiently and will be embedding into the over laying lift of the wall masonry giving a well bonded, and consequently, a water tight joint.

The vertical construction joints in the wall shall be of tongue and groove type. The groove of these joints shall be 300 mm x 300 mm and it shall be provided 300 mm away from the water face of the wall. These joints shall be provided with PVC water stop at a depth of 200 mm from water face which shall be primarily responsible for the water tightness of the joints. These joints shall have a plain finish for a depth of 300 mm from water face by virtue of its casting against vertical face of the centering of vertical face of the previously cast panels cast butting against each other while the remaining depth beyond 300 mm shall have masonry facing which will present a rough surface and thus provide a good bond between the consecutive panels.

In the case of divide wall the water stop shall be located at the centre of the key which shall be located at the centre of divide wall. The key shall be of the same dimensions as that in the end walls.

The construction joints in the bottom layer of the floor which shall be cast in concrete shall be cast against vertical stopping off boards. On the water face the vertical joints shall have a groove provided with bitumen of 12 mm x 20 mm size which shall be filled with polysulphide sealant material.

No such special treatment need be done for the joints provided in the roof slab, bottom layer of the floor and the horizontal joints in the wall. The joints in roof slab and bottom layer of the floor shall however, be staggered with those in the overlaying layers such as brick bat coba, I.P.S. and top R.C.C. layer of the floor to minimise the chances of leakage by increasing its path, if any.

Complete Construction Joints

These joints are provided in the top layer of the floor of the reservoir with a view to localise shrinkage cracks at these joints. These joints are characterised by complete discontinuity of steel without any initial gap as in the case of expansion joints. The joints between the adjacent panels of the floor shall be provided with a groove at top of dimension 12 mm x 20 mm and it shall be filled with polysulphide sealant and they shall be provided with water stops as specified earlier.

The joint between top layer of the floor and the walls or between the top layer of the floor and the column footing, shall also be provided with a groove of 12 mm x 20 mm which shall be filled with sealant material as per specifications given below:

Joint Fillers : Joint fillers shall be of durable, compressible and non-extruding material. It shall be non-staining, non-absorbent and compatible with sealant material used.

Sealant Material: The joint sealing compounds should be capable of properly ensuring water tightness in vertical and horizontal and inclined joints in water retaining and other structures having severe service conditions in respect of anticipated movement or exposure to weather. Typical uses include expansion joints in the walls of water tanks, and in roof and deck slabs exposed to the weather.

The compound should be flexible, durable and weather proof and should have sufficient elasticity to allow joint movements of the concrete components wherever necessary.

The sealant shall be polysulphide rubber sealing compound conforming to BS 4254 of 1967 or ASA-A 116-1-1960 or any other equivalent specifications. It shall be capable of cold pouf application for horizontal joints and cold application of vertical and inclined joints. The sealing compounds shall be suitable for use in the tropics where it will be subjected to high ambient temperatures, humidity and very strong sunlight. It shall not degrade under these conditions and shall be suitable for use with raw and treated water including water dosed with chlorine. The sealant shall be odour and taint free from lead. It shall be available in choice of colours and shall give a tough, permanent seal, be waterproof, non-staining and remain resilient. Sealing compounds for vertical and horizontal joints shall be used complete with the appropriate quantity of primer as per manufacturer's instruction for use. The primers should ensure good adhesion to the concrete and should be specially developed for respective sealing compounds. The sealants shall be applied with pressure guns or without guns as specified by the manufacturers. Sealing compound shall be fully cured before water is permitted to come in contact.

The sealant material should be formulated as to have a storage period of one year at a temperature of 40°C.

Epoxy Coating and Bituminous Painting

Epoxy Coating

General

Epoxy coating is to be applied to the internal surface of the unit wherever specified. The thickness of epoxy film shall be 300 microns.

Materials

A solvent free epoxy coating like “Araldite GY 255” manufactured by Hindustan CIBA Geigy Limited, Bombay or equivalent product of FOSROC is to be used for forming the film. In case of use of an equivalent it should be got approved by the Employer placing supply orders. Materials used and process of application to the concrete of other surfaces should be strictly according to the instructions of the suppliers of the epoxy. Araldite GY 255 one part by weight is to be mixed with 1 part by weight of Hardener H Y 45. The viscosity should be such that it is convenient for brush application.

Subsurface Preparation

The concrete surface should be cleaned thoroughly by sand blasting. The mild steel parts also are to be cleaned to be free of grease and thoroughly sand blasted. The coverage should not be more than 6 sq.m. for concrete and 5 sq.m. for mild steel per kg of epoxy respectively.

The moisture content of concrete before application of epoxy coating shall be less than 4%. This has to be checked properly through a small sample. To achieve this epoxy coating shall be done in hot season.

Curing

The curing should be done for 7 days at room temperature. If the temperature is less than 15°C the space should be warmed up by incandescent lamps, heaters, blowers or infrared lamp. The instructions of the supplier manufacturer of the product both as for use of materials and application take priority over the above instructions and they should be followed very rightly.

Bituminous Painting

Two coats of bituminous paint of 80/100 grade, with 1.65 kg/m² spread will be provided on internal face of sludge sump.

Material

The material shall be of best quality un-pigmented bituminous base paint of such a composition as to satisfy the requirements of IS-9862. with total volatile matter contained in the paint shall not exceed 55% by weight.

At least 95% of the solid materials shall be soluble, in carbon di-sulphide or in benzene, and the closed flash point as determined in Abel's apparatus shall not be less than (86°F)30°C. The paint shall remain liquid and retain its consistency at the ordinary atmospheric temperature when packed in suitable containers. The drying time shall not be less than 2 hours and not more than 8 hours, and after drying, paint shall not show any surface cracks, tendencies to powder or discoloration due to weathering action or expansion and contraction. It shall also be able to resist the action of acids and alkalis. It shall not soften under the action of mineral turpentine.

The film resulting from brushing the material on a strip of tinned iron, 30 standard wire gauge after being allowed to dry at room temperature not below (65°F) 18.3°C for 48 hours shall not, when bent double over a (quarter inch)6 mm dia rod, show any signs of

flaking or cracking. The time occupied for the actual bending shall not exceed one second. When the paint has dried hard, a 4H pencil should not be capable of scratching it. The weight of the paint shall be firm 0.83 to 1.25 kg per liter, the component of the paint shall be such as not to react with water chlorinated or otherwise and develop poisonous or harmful elements thereto.

The paint shall be of Indian manufacture of approved make and quality

Application

All corners and junctions shall be properly rounded off to present a uniform and smooth finish. After complete curing of the plaster, it will be allowed to dry up. After drying the moisture content shall be brought to a value less than 4% by using a below-lamp. The surface should be well cleaned with smooth brush to make it dust free. The coating shall be allowed to dry and kept in dry condition till final setting takes place.

Door, Windows, Grills, Shutters, etc.

Relevant IS Codes

IS:1003 (I)	:	Timber paneled and glazed door & ventilator shutters
IS:1003 (II)	:	Timber paneled and glazed window & ventilator shutters
IS:1038	:	Steel doors, windows & ventilators
IS:1081	:	Fixing & glazing of metal doors, windows & ventilators
IS:1361	:	Steel windows for industrial buildings
IS:2202	:	Wooden flush door shutter (solid core type)
IS:2202 (I)	:	Plywood face panels
IS:2202 (II)	:	Particle board and hardboard face panel
IS:4020	:	Methods of test for wooden flush doors
IS:6248	:	Metal rolling shutters & rolling grills
IS:7452	:	Hot rolled steel sections for doors, windows & ventilators
IS:10451	:	Steel sliding shutters
IS:10521	:	Collapsible gates

General

The items under this clause cover doors, windows, grills, rolling shutters, collapsible gates etc. normally required to be provide in a building used whether for residential, office, laboratory or industrial purpose.

Doors and windows Shutter shall be of Teakwood as specified in the bill of quantities/drawings or as directed by the Engineer. The sizes of the above items and locations of the same shall be as shown in the drawings.

The frames and shutters shall be of either steel or wood of thickness of members as shown on the drawings. The material used shall be of good quality seasoned timber of specified wood or rolled steel sections as the case may be.

They shall be provided with all necessary fittings like hold fasts, hinges, locking arrangements stoppers, eyes and hooks, tower bolts, handles, fixing lugs etc., of sizes and quality grade as specified.

They shall be provided in complete form including painting, glazing, fixing in position true to level and plumb.

Steel rolling shutters shall be of approved make and shall conform to IS **6248 - 1979**. Metal rolling shutters and rolling grills.

The builder's hardware shall all be as per relevant Indian Standards.

Woodwork in Doors, Windows, Partitions, Louvers, Railings etc.

Wood used for all work shall be the best of the respective class specified, and properly seasoned by at least 6 months air drying, suitable for joiner's work, should be of natural growth, uniform in texture, straight grained, free from sapwood, dead knots, open shakes, boreholes, rot, decay and any and all other defects and blemishes.

The thickness specified for joiner's wrought timbers are, unless otherwise specified, prior to planning and 3 mm will be allowed from the thickness stated for each wrought faces.

All joining shall be wrought on all faces and finished off by hand with sandpaper, with slightly rounded arises.

The joints shall be pinned with hard wood pins and put together with white lead. Jointing shall be by means of mortise and tenon or dovetailed joints as approved.

Any joiner's work which shall split, fracture, shrink, or show flaws or other defects due to unsoundness, inadequate seasoning or bad workmanship, shall be removed and replaced with sound material at the Contractor's expense.

Doors, windows and ventilator frames, transoms and mullions shall be rebated. All dimensions shall be as per drawings. The top framing member of doors and top and bottom framing of windows and ventilators shall project about 20 mm below finished floor. Surface coming in contact with brickwork shall be painted with bitumen as directed by the Engineer-in-charge. Each of the door and window frames shall be provided with 3 Nos. M. S. 25 x 25 x 6 flat split holdfasts on each side. These holdfasts shall be embedded in masonry of concrete work. The work shall conform to IS:4021.

The doors shall be paneled or solid flush doors as described in the item of work. All flush doors shall be supplied with approved fittings such as hinges, mortise lock of approved make with handles on both sides, oxidised brass tower bolts and latch arrangements, door stops etc. and as shown in drawings but exclusive of door closers. Door closers, where separately specified shall be of heavy duty hydraulic type to be approved by Engineer-in-charge. Paneled doors shall have the same fittings except in place of union lock, an aldrops shall be provided. Each door leaf shall have two 250 mm tower bolts, two aluminum or oxidised brass handles, and one door stopper be made of weatherproof plywood. Flush doors shall conform to IS:2202 (Part-I).

Doors will generally have no sills but if a few have to be provided, the Contractor shall do so at no extra cost to the Owner.

The type of window shall be as specified. Each shutter shall have one pair of hinges, two tower bolts (one 225 mm long and another 150 mm long), one handle and one hook with eye and pegstay. Ventilators shall have two M. S. hold fasts and hinges, one handle and one hook and eye at each and one small tower bolt in the centre. Where so directed by the Engineer-in-charge, the doors and windows shall be provided with parliamentary type hinges at no extra cost.

The workmanship of all door and window shutters shall conform to the requirements of IS:1003 (Part-I & II) and IS:2202 (Part-I). If required, flush door panels shall be got tested as per IS:4020.

Cupboards, almirahs and shelves shall be provided as per Engineer-in-charge. The doors could be of either hinged type or sliding type as approved by the Engineer-in-charge. All dimensions as furnished in the drawings shall be followed. Fixtures and fittings as shown on drawings or as directed by Engineer-in-charge shall be used.

Railings and architraves shall conform to the shape shown on drawings or as approved and fixed by means of screws (counter sunk or otherwise) or bolts.

The finish expected is of a very high order and the work shall be all-inclusive weather or not all detailed specifications have been spelt out and the work shall be free from blemish.

No iron bars or grills are proposed to be provided in the windows or ventilators. Glass louvered ventilators where specified shall be provided.

Glazed windows, louveres, ventilators and doors shall be provided with either clear or pinheaded glass 5.5 mm thick which shall be free from all blemishes and shall conform to IS:1761. It should be clearly understood that glass which does not have uniform refractive index or which is wavy will be rejected. Woodwork shall not be painted, oiled or otherwise treated before the Engineer has approved it.

Steel Doors, Windows and Fittings

The steel doors, windows, ventilators shall conform to IS:4351 and IS:1038. All steel doors windows, ventilators, louveres etc. shall be of sizes as specified and conform to the description in the respective item of work. Whether or not specifically mentioned, all fixtures and fittings necessary for the satisfactory operation of the doors and windows shall be provided. Doors, windows and ventilators shall be obtained from an approved manufacturer. Specific approval for such purchase shall be obtained before hand. Sample shall also be got approved before further manufacture starts, unless this is waived in writing by the Engineer-in-charge. All steel doors shall be of pressed steel (18 gauge) flush type with or without removable transoms. All doors shall be provided with a three way bolting device and locking arrangement with duplicate keys and handles of both sides and operable from either side. The Contractor shall obtain windows with friction hinges in place of windows with pegstays if so directed by the Engineer-in-charge. For centre hung and top hung ventilators suitable spring catch/pulley and chord arrangement shall be provided for facility of opening. Whenever fly mesh over windows have been called for, they shall be fixed on the window and suitable lever type or rototype arrangement shall be provided for opening or closing of the glazed panels from inside. Prior approval of Engineer shall be taken before order is placed with the manufacturer.

Where specified, steel doors supplied shall be airtight. For this purpose, the Contractor shall provide necessary padding material such as rubber, felt or any other approved material.

Rolling Shutters

The rolling shutters shall conform to the size indicated in drawings and shall be of quality specified in the Schedule of Quantities. The rolling slats shall be in one piece and be made of heavy gauge steel sheets minimum 18 SWG in thickness. A cylindrical hood shall be provided on the top to enclose the shutter when it is open. The rolling shutters shall be provided with suitable locking arrangements and deep channel guides, In case galvanised rolling shutters are specified the rolling shutter shall be made of hot dip galvanised slats, hood, deep channel guides all preferably in one piece.

In case of hand operated pull & push type rolling shutters of sizes larger than 10 sq.m. in area and in case of very large gear operated and/or as directed by the Engineer, rolling shutters shall be provided with ball bearings for smooth & efficient operation. In case of large rolling shutters & depending upon local wind conditions, the rolling shutters should be provided with special locking type of wider channel guides or it shall be provided with central moveable channel supports to take up design wind pressures in the area.

Hand Railing

Hand railing and vertical posts shall be made from galvanised mild steel pipes and fittings. The design of the railing shall be approved by the Engineer to whom the Contractor shall submit manufacturer's drawings showing positions of vertical posts, joints, expansion joints and joint details and all fixing details. Fabrication shall not start until these drawings have approved by the Engineer.

Hand railing and vertical posts fabricated from galvanized mild steel pipes and fittings shall conform to the following requirements.

The height of the top railing shall be 1050 mm above finished floor level unless otherwise shown. The lower railing shall 550 mm above finished floor and Toe plate should be provided at the bottom of the rail of the size 100mm wide x 5 mm thick subject to the Engineer's approval these and other leading dimensions may be varied slightly to suit manufacturer's standard products.

Unless otherwise shown, handrails and vertical posts shall be made of galvanized mild steel tubes (light class) of 32 mm nominal bore and fittings such as Tees, Bends, Crossed etc. of heavy class conforming to IS:1239.

In general the vertical posts shall be spaced at 1.5 meter c/c and shall be built into the concrete or bolted to the MS plate embedded in concrete as shown on detailed drawing.

Hand railing and vertical posts shall be painted with 2 coats of approved paint.

Rungs

Rungs shall be provided in all manholes/inspection chambers/pumping stations over 0.6 m in depth and shall be of cast iron conforming to IS:5455. These rungs shall be fixed staggered in two vertical runs, 300 mm apart horizontally and 300 mm c/c vertically. The top rung shall be 450 mm below the manhole/inspection chamber cover and the lowest not more than 300 mm above the benching. The rungs shall be of 20 mm diameter with epoxy paint for corrosion resistance.

INTAKE WELL

The intake structure is provided for drawl of water from more than one level to cope up with seasonal variations of depth of water. Port holes and inlet pipes shall be provided at different levels for drawl of raw water from the reservoir.

The Intake well, Inlet pipes and other structures under water and above bed level shall be well protected against possible damages from the moving objects.

Under mining of foundation due to water current or overturning pressure due to deposits of silt against one side of an intake structure are to be avoided.

The entrance of large objects into the intake well shall be prevented by coarse screen. Fine screen for exclusion of small fish and other objects shall be placed at the accessible point. The area of the opening in the inlet pipes shall be sufficient to ensure an entrance velocity greater than 1 (one) meter per second. Submerged ports in the intake well shall be provided in such a way that the rate of flow of inlet water through the inlet pipe and through the port hole is greater than the rate of maximum discharge from the well at the lowest level of water in the reservoir.

Intake well foundation shall rest on any soil including rocks. In case a well is founded on rock there shall be adequate embedment and even all round seating.

Minimum embedment of the foundations into the rock shall be as follows: -

For hard rock with an ultimate crusting strength 10 MPa or above arrived at after considering the overall characteristics of the rock, such as fissures, bedding planes etc. = 0.6 meter

For all other cases = 1.50 meter

The well shall as far as possible be sunk true and vertical by excavating materials uniformly from inside the dredge holes. If necessary, Kent ledge shall be placed in any orderly and safe manner and in such a way that it does not interfere with dredging operation. Eccentric Kentledge shall also be used for rectification of tilt with the approval of Engineer-in-charge / Consultant. Dewatering of well as means for sinking is discouraged and it shall be avoided if sand blows are expected. It may, however, be resorted to under special circumstances on specific permission of the Engineer-in-charge / Consultant. Water jetting may be employed for well sinking wherever necessary. Explosives shall not generally be used as an aid for well sinking but in cases where explosives become imperative, prior approval of the Engineer-in-charge / Consultant shall be obtained. The dredged materials shall be dumped as far as away from the well sinking point as possible and then continuously and simultaneously removed. In case the river stream flows along one edge of the well being sunk, the dredged material shall not be dumped on the dry side of the bank. Deep sump shall not be made below the well curb. Tilt and shift of intake well shall be measured regularly everyday during the entire sinking operation.

Corrective measures shall be taken at every stage of sinking to ensure that at the final stage the tilt does not exceed 1 in 60 and the shift is limited to 150 mm. Mild blasting only with the permission of Engineer-in-charge may in some cases be used for seating the well after it has reached the founding level, but in such cases 24 hours shall be allowed to be elapsed, before the bottom plug is laid. The well after being sunk to its final position and after

ensuring that the soil properties of the founding strata do not significantly differ from these adapted in design shall be suitably plugged at its bottom.

Intake well shall be constructed with RCC of M – 25 grade concrete and HYSD / TMT bars for reinforcements. Steining, floors shall be constructed with Pump House on the top of the well and 6 (six) numbers of Pumps, Motors and other electrical accessories, pipes, valves etc. are on the floor of the Pump House. There shall be one moving crane for lifting of Pumps, Motors, Pipes and Valves etc. The crane shall rest on two R.S.J. (as per design). The bottom plug shall be laid with mass concrete of proportion (1:1.5:3) and its thickness shall not be less than 2000 mm. An RCC bottom cap 300 mm thick shall be laid over the bottom plug with M – 25 grade concrete and HYSD / TMT bars as per drawing.

Intake pipelines: -

There shall be 3 (three) no. of 400 mm NB (406.40 mm OD) and wall thickness 9.50 mm (as per IS: 3589) steel intake pipe lines from the intake well upto the desired place inside the reservoir by jack pushing with hydraulic jack or by any other means as necessary for laying the pipe lines below R.L. m (lower level) and R.L. m (middle level) partly under and partly above the bed level reservoir. Total length of the lower level (i.e. at R.L. m) and middle level (i.e. at R.L. m) shall be approximately 150 (one hundred and fifty meters), however this length may vary on account of technical requirement and the contractor has to carry out the work as per drawing. In the event of presence of soft or hard rock on the alignment of these two intake pipe lines the rock shall be excavated either by mechanical means or by using explosives. If explosives are to be used for blasting of hard rocks necessary permission shall have to be obtained from the Engineer In Charge /Consultants.

If necessary, bailing out of water shall have to be done for laying of 400mm diameter inlet pipe lines from the intake well upto the required point in the reservoir.

If the jack pushing is found not possible due to presence of rocks / boulders etc. no additional payment for bailing out of water shall be entertained.

After laying of intake pipe lines in the reservoir the exposed part of the pipe lines above the bed level of the reservoir shall be anchored by driving 2nos R.S joists (ISMB 200mm x 100mm x 10.8mm thick flange) on either sides of the pipe lines upto the depth of 6(six) meters below the bed level including providing the fitting fixing the inlet pipe lines with the RS joists by means of 150mm wide and 10 mm thick M.S. saddle plates with nuts bolts and rubber insertions in position as per drawing to protect the inlet pipe lines from possible damage by the moving objects under water . Anchoring shall be done as stated above at 5.0 meters apart for both the pipelines laid above the bed level.

Choosing a Well Site

The well shall be accessible for cleaning, testing, monitoring, maintenance and repair. The ground surrounding the well is sloped away from the well to prevent any surface run off from collecting or ponding. The well is up-slope and as far as possible from potential contamination sources such as septic systems, barnyards or surface water bodies'. The well is not housed in any building other than a bona fide pump house. The pump house must be properly vented to the outside to prevent any buildup of dangerous naturally occurring gases. The well is not located in a well pit.

Minimum distance requirements

Provincial regulations outline minimum distance requirements as follows. Equivalent imperial distances in feet are rounded up to nearest foot. The well must be:

10 m (33 ft.) from a watertight septic tank

15 m (50 ft.) from a sub-surface weeping tile effluent disposal field or evaporation mound

50 m (165 ft.) from sewage effluent discharge to the ground

100 m (329 ft.) from a sewage lagoon

50 m (165 ft.) from above-ground fuel storage tanks

3.25 m (11 ft.) from existing buildings

2 m (7 ft.) from overhead power lines if:

the line conductors are insulated or weatherproofed and the line is operated at 750 volts or less

6 m (20 ft.) from overhead power lines if the well:

does not have a pipe and sucker rod pumping system

has a PVC or non-conducting pipe pumping system

has well casing sections no greater than 7 m (23 ft.) in length

12 m (40 ft.) from overhead power lines for all other well constructions

500 m (1,641 ft.) from a sanitary landfill, modified sanitary landfill or dry waste site.

The installation of a leaching cesspool is no longer permitted. It is, however, highly recommended that any newly constructed water well be located at least 30 m (100 ft.) from any existing leaching cesspool

Well Design Considerations

Well design and construction details are determined after a test hole has been completed and the geological zones have been logged. There are many components to well design the driller must take into account. Decisions will be made about:

Well depth

Type of well

Casing material, size and wall thickness

Intake design

Formation seal

Monitoring and preventive maintenance provisions.

Well depth

During the test hole drilling, the drilling contractor will complete a formation log. Soil and rock samples are taken at various depths and the type of geologic material is recorded. This allows the driller to identify aquifers with the best potential for water supply. Some drillers also run an electric or gamma-ray log in the test hole to further define the geology. This gives them more accurate information about aquifer location.

Generally a well is completed to the bottom of the aquifer. This allows more of the aquifer to be utilized and ensures the highest possible production from the well.

Raw Water Pump House: -

The pump house shall be circular and shall be constructed above the Intake well. The floor of Pump House with RCC beams shall be constructed to withstand the load of 6 (six)

numbers of Pumps, Motors, Column Pipes, Delivery Pipes, Valves and other electrical accessories, H.O.T. crane etc. as well as part of the load coming from the Approach Bridge which shall rest on the floor at one end. The pump floor and RCC beams shall be M – 25 concrete and HYSD / TMT bars (Fe - 415). Internal diameter of Pump House shall be around 8 (eight) meters. The walls of the Pump House shall be 250 mm thick 1st class brickwork with 1:4 cement mortar (1cement and 4 sand). There shall be 8 (eight) numbers of RCC columns along the centre line of periphery of the circular brick wall and equally spaced for the support of 2 (two) nos. of Rolled Steel Joists (RSJ) and RCC Roof beams as shown in the drawing. The columns shall be constructed to support the RSJs over which HOT crane shall be fixed for lifting the Pumps, Motors, Pipes, Valves, and Electrical Accessories as well as to support RCC roof beams. The columns, bracings, Ties, Lintels, Chujja, RCC roof beams and roof slab shall be of RCC concrete of not leaner than M – 25 and HYSD / TMT (Fe - 415) bars.

Finished surface of Motor floor level shall be at RL M. the top of the motor floor shall be finished with 52 mm thick cement concrete flooring with concrete hardener topping.

The door shall be of Steel rolling Shutter of 2.50 M × 2.00 M in size.

There shall be adequate ventilation in the Pump House. At least 4 (four) numbers of steel window with sheet glass, size of each window shall be 1.50 M × 1.00 m.

One Low Tension (L.T.) Panel Board Platform shall be provided at 2.50 M above the floor level. The Platform of Panel Board shall be of RCC slab of M – 25 grade concrete and HYSD / TMT bars supported by one RCC beam at the inner side and 250 mm thick circular brick wall at the other side.

(k) Reduced level at different points of the Intake well and Reservoir. (Tentative)

(i) Bed Level of the reservoir = -----M (GTS) to ----- (GTS) sloping towards

(ii) High Water Level (HWL) = ----- M

(iii) Dead storage level = ----- M (in the month of -----)

(iv) Proposed lowest water level in the reservoir = -----M.

(v) Top of the approach bridge level = ----- M.

(vi) Pump house floor level = ----- M.

(vii) H.O.T crane level (top of RSJ) = ----- M

(viii) Pump House roof level = ----- M

(ix) C/L of lower level intake port / pipe = ----- M

(x) C/L of middle level intake port / pipe = ----- M.

(xi) C/L of upper level intake port opening = ----- M.

(xii) Conservation level of the reservoir
(at which level the pump will be
Operated during the monsoon) = -----M.

\

Storage Capacity of Intake Well: -

Minimum storage capacity of Intake well shall be 15 (fifteen) minutes storage at the lowest level of water in the reservoir and at average rate of pumping for 16 hours operation of pumps in a day.

GENERAL SPECIFICATIONS FOR INTAKE WELL

1. EXTENT OF WORK

1- This specification provides for the construction, supply, delivery, erection, testing, and setting to works of dry intake well at the bank of river and an approach bridge.

2- The said dry intake well is required for the installation of raw water pumping plants to pump the river water to the site of treatment plant for group of villages w/s scheme as described in schedule 'A' . The pumping plants shall have positive head for suction. Intake well shall be of 6 Mts. Internal diameter. Height of the well shall be kept 17 Mts. upto the platform level. The platform level shall be approachable from the bank of the river through a 2.00 m. wide R.C.C., bridge. The bridge is also included in the scope of the work.

The proposed site for the above works shall be as shown in schedule 'B'. The contractors are advised to see the site of proposed works and get them acquainted as nothing will be entertained later on for want of knowledge of proposed construction site.

2. WORKS INCLUDED IN THE CONTRACT:-

The raw water for group of villages water supply scheme is to be pumped from the river The following works have been proposed under this contract.

(A) Dry R.C.C. Intake well ... M internal diameter and its appurtenant works. A rough sketch of intake well is attached with the tender form. It consists of the following parts.

(a). A R.C.C. well having inner diameter as 6.00 m and height as mtrs. The invert level of the well is to be kept at least 3.00 mtrs. below the minimum water level in the river as to keep positive suction on the pumps . The minimum water level at the intake well site is defined as the minimum water level recorded during the year of execution or may be considered further 0.5 mtrs. below the actual recorded as above . The intake well is of dry sump type. It should be perfectly water proof upto the well height. For tapping the river at different levels inlet pipes of approved diameter (to supplied by contractor.) .shall be

grouted at low level, medium level and high levels as directed by the Engineer Incharge. The actual levels shall be given by the Engineer Incharge at the time of execution. The lowest water level Inlet pipe shall be grouted at near the bottom of the bed upto the minimum water front. The various inlet pipes shall be fitted with Sluce Valves (ISI Marked) to be supply by contractor of specific pressure as directed by engineer these inlet pipes will be connected to a main down pipe of approved diameter. The inside and outside surface of the well should be rendered plastered finish.

- (b). At the complete height of the intake well defined above as mtrs. the well shall be half covered by a R.C.C. , slab . This level shall be called as Platform level. At this platform the well shall also be surrounded by 1.0 mtrs. wide projection all around which shall be called as Balcony. This slab and balcony shall be designed for carrying 1000 Kg. / sq. m. live load, but these slabs and projections shall also be checked by considering 1000 kg. as point load. The half platform and the balcony all around shall also be provided with suitable railing.
- (c). A round room shall be constructed with a clear height of 3.5 mtrs. above the platform level over the outer periphery of the well , which shall be called as pump house . This shall be constructed either in R.C.C. or 1 thick brick masonry wall with suitable no. of columns in between and R.C.C. lintels with parapet wall and shall be provided with suitable numbers of doors and windows as desired by Engineer Incharge . This pump house shall be provided with a 6.40 mtrs. (approx) long girder at centre capable to carry a moving load of pumps with the help of chain pulley block.
- (d)- A steel of R.C.C., stair case shall also be provided inside of the well as to approach the invert level of well from the platform level. This stair case shall go along the inside periphery of the well and shall start beyond the R.C.C., platform, it shall have a rise not more than 17.0 cm. and the average trade not less than 22.5 cms. The width of stair is to be kept as 0.75 and shall have complete railing at one side and a top rail along the wall of the well. This stair case shall be designed for carrying a live load of 300 kg on each step. At the level of each inlet pipe a landing platform of about 1.0 x 0.75 m. with suitable arrangement of approach upto landing platform from the platform level of intake well shall also be provided for operation of valves.

(B) Approach bridge.

A R.C.C. bridge is to be provided to approach the platform level of the well from the bank of the river. This bridge consists of the following works.

- (a) Approximately 10 mtrs. long and 2.0m wide R.C.C. bridge shall be designed to carry a moving live load of 1000 kgs and extra 1000 kgs.(approx) for the load of the 250 mm dia ERW pipe and the water content In , which will pass over the bridge . The 1000 kg. load for pipe and the water content shall be considered in such a manner that if the pipe is laid along the designed alignment It shall not create any hindrance in a clear pass way of 2.00 mtrs. The proposed alignment shall also be accessible in such a manner where pipe could be laid afterwards and can be repaired if required any time in future. The bridge shall have proper railing on both sides.

- (b) It also includes the works of embankments supporting pillars in between or at the side of the Intake well whatever required for the support of the proposed bridge. These works may be of stone masonry or R.C.C. and shall be designed considering the safety of the structure during the high flood conditions of the river and the current of flow.

3. Design Drawings:-

The sketch diagram of proposed Intake well is attached with the tender and is indicative and for information only. The tenderers shall give his own proposal for the same.

The tenderer shall include architectural treatment to structures to merge with over all architectural view of the complex.

The tenderer shall furnish the three copies of full structural design and all relevant drawing of the intake well and R.C.C. bridge including levels, construction standards and materials proposed to be used for civil structures, details of erection and maintenance etc. complete. For proper appreciation and assessment of his offer necessary clarifications shall also be given if required for checking the process design and layout drawings.

The design calculations both for design and for individual structures should be complete with references to codes, relevant literatures sketch, for clarification wherever regd .

The tenderer shall be responsible for the correctness and the soundness of the final design. The structure shall be as per recognized engineering practice and if any provision are found inadequate or faulty necessary modification will have to be carried out at any stage upto the expiry or the performance guarantee period at no extra cost.

4- TESTING

After completion of all the works the testing of both the structures shall be done by the contractor at his own expense.

Intake well shall be tested for water tightness and stability during the maximum water level in the river and also during the minimum water level.

R.C.C. bridge shall be tested for maximum load for which it has been designed by providing artificial load and measuring the sag in the bridge. All the tests shall be carried out on the contractor's own risk and at his own expense in all respects. The contractor will have to give all the tests by making his own arrangements. The contractor shall rectify the defects noticed and carry out the tests again and repeat the testing operations till successful result is obtained and accepted by the Engineer in charge. The rates quoted for the work shall be considered as inclusive of cost of all labor, material and plant reqd. to give successful tests and for water tightness. Along with the design contractor shall also provide detailed procedure for testing of the structure.

5- Diversion of river for construction:

Diversion of river water for the execution of Intake well is the most important item for successful completion of the work, so contractor is advised to visit the Intake well site and shall have the idea of expenses in the diversion of river water.

These works are also reqd to be dismantled and the material shall be removed from the site so that the proper flow of water upto inlet pipes of pumps may take place. The tenderer shall include all above expenses in his rates.

6. DEWATERING :

The contractor shall provide for the purpose of excavation under water all the necessary dewatering equipment like well point system, pumps, pipes conduits etc and make necessary arrangements for proper drainage of the pumped water from such systems and its easy disposal without affecting the site for such disposal of water to other areas. The contractor shall change the dewatering equipment in such a way that the excavated pit should always remain dry while the excavation and concrete work upto ground floor level is going on, the dewatering process shall be carried out till the concrete in works as mentioned above has set sufficiently and as directed by Engineer Incharge..

These works also include rendering all R.C.C., works in plastered finish, plastering, flooring, as reqd and directed, distempering inside surfaces and snowcem on outside surface and painting all steel and wooden structures by approved quality of material approved colour and in approved number of coats as per the instruction of Engineer Incharge. The security shall be paid only after proper testing of structures during high flood conditions and low water conditions.

Works also include the supply of all material T&P etc. reqd. for proper completion of works.

Works also include the cost of bearing capacity testing and other tests required for proper designing of structure and test reqd. as to know the scouring depth of the river. No extra Payment will be made for above works.

7. Blasting:

Blasting is prohibited the Engineer shall have power to regulate, restrict or prohibit blasting. However if in his opinion it is necessary to do so, care should be taken for the safety of person or property or to safeguards the works. No. blasting shall be carried out in any part of the work without, permission in writting of the competent authority, such permission shall not absolve the contractor from any of his obligations, or inabilities under contract and he shall be take all necessary precaution including the use of blasting nets to avoid damage, loss or injury to persons and to public or private properties.

The contractor shall keep the Engineer fully informed at all time when blasting is proposed to be carried out and of any details to Engineers may require concerning strength of charges and their positions. Explosive shall not be used with in fifteen meters, or such greater or lesser distance as the Engineer may direct of concrete placed in the works, of any existing structures water main, electric cable, sewer or other services.

The contractor shall obtain the necessary licenses for the storage, transports and handling or explosives and shall provide a store suitable for explosive and shall carry out every aspect of blasting work in full conformity with the regulations of all competent authorities including the police and the Inspector or explosive ,U.K. State, only experienced and competent blasting operator possessing license from the Commissioner of Police shall be employed on blasting work, Audible and visible warning (such as the waving of red danger flags and the beating to goods) shall be given for the last five minutes before blasting is due to begin.

The contractor 's foreman or other responsible shall inspect the whole of the blasting area during the warning period to ensure that no one remains within or is

likely to enter danger area. All operators except those responsible for denoting the explosive shall be removed to a safe distance which in any case shall not be less than two hundred meters. If combustible fuses are used these shall be cut to length before insertion. The contractor's foreman shall compare the number of charges placed with the number of shots heard to determine whether any charge has not exploded. Under no circumstances shall the removal of explosive charges be attempted. The hole containing the charges shall be marked and filled with water. A second hole shall be drilled some way charged and fixed. The procedure shall be repeated until the foreman is satisfied that both charges have exploded. In general the size of explosive charges used shall be the smallest compatible with efficient working so as to minimize the chances of danger to person and property.

8. Structural Steel Work:

Structural steel work and design and fabrication of steel shall comply relevant IS code

9. Welding:

In all cases where welds are liable to be highly stressed and Contractor shall supply to the Engineer before fabrication commences, detailed drawings of all welds preparation proposed. No such welding shall be carried out before the Engineer has signified his approval of the details proposed. No alteration shall be made to any previously approved detailed of weld preparation without prior approval of the Engineer.

Welders shall be qualified in accordance with the requirements of appropriate section of Indian Standards.

All tests, if required, shall be carried out in the presence of Engineer.

All welded components shall be stress relieved prior to machining.

Infiltration galleries

An infiltration gallery is a porous barrel inserted within the aquifer either axially along or across the ground water flow with a collecting sump at the end from which the water is pumped out. The collecting well is the point at which the maximum head of depression is imposed under the pumping operation, the depression head being diffused throughout the length of the gallery to induce the ground water flow from the farthest reach. The normal cross-section of a gallery comprises loosely jointed or porous pipes or rows of pipes enveloped by filter media of graded sizes making up a total depth of about 2.5 metres and a width of 2.5 metres and above depending on the number of pipes used for the collection of the infiltrated water. If located in a river bed the top of the gallery has to be much below the scouring zone in the river under high floods.

The coarse aggregate envelope consists of three layers followed by coarse and medium sand layers as detailed below:

- a) Filtering medium - 38 mm broken stone near pipes
- b) Second layer - 38 to 19 mm broken stone
- c) Third layer - 12 to 6 mm broken stone
- d) Fourth layer - Coarse sand passing through a sieve of 3.35 mm size and retained on a sieve of 1.7 mm size.
- e) Fifth layer - Fine sand retained on 70 micron sieve and pass through 1.7 mm sieve.

Bored Well / Tube Well

Bored wells are tubular wells drilled into permeable layers to facilitate abstraction of ground water through suitable strainers into the well extending over the required range or ranges of the water bearing strata. There are various ways of drilling such wells through different soils and for providing suitable strainers with gravel shrouding, where necessary.

These wells are used for obtaining water from shallow as well as deep aquifers. Open end tubes are sunk by removing the material from the interior by different methods.

After the required depth is reached the pipe with the cutter is taken out of the bore and the well pipe with the strainer is then lowered into the hole. The annular space between the bore and the well screen is then shrouded with pea gravel. Casing of wells in soft soils must be cased throughout. When bored in rock it is necessary to case the well at least through the soft upper strata to prevent caving. Casing is also desirable for the purpose of excluding surface water and it should extend well into the solid stratum below. Where artesian condition exists and water will eventually stand higher in the well than the adjacent ground water, the casing must extend into and make a tight joint with the impervious stratum to prevent escape of water into the ground above.

Large casing is generally made of welded or riveted steel pipe. For smaller sizes of pipes which are to be driven, the standard wrought iron pipes are generally used; for heavy driving, extra strong pipe is necessary. The life of the pipe is affected by corrosion due to the carbonic acid encountered in some cases. The use of rust resisting alloys is advisable in such cases. Non-reinforced plastic, usually PVC casing up to 100 mm dia and reinforced plastic casing and fibre glass for longer dia up to 400 mm, are coming into vogue. In providing the strainer arrangement whereby water is admitted and sand or gravel excluded, it is desirable to make the openings of the strainer as large as practicable to reduce friction while at the same time preventing entrance of any considerable amount of sand. Where the aquifer consists of particles that vary widely in size, however, the capacity of the well is improved by using strainer openings through which the finer particles are drawn into the well while the coarser ones are left behind with increased void space. The size of openings may be selected after a study of the mechanical analysis of the aquifer material to permit the passage of all fine particles representing a certain percentage, by weight, of the water bearing material.

WATER TREATMENT PLANT

Design of structurally sound having aesthetic look structures and construction of Water Treatment Plant consisting of Aerator, Flash mixer, Clariflocculator, Rapid sand gravity filter with filter house, Clear water reservoir (Sump), Pure water pump house, Chemical House, Chlorine house, Filter back wash tank etc. complete as per BOQ.

The total designed water demand is for intermediate stage. It is proposed to keep the working hours of water treatment plant (WTP) as 16 hours. Thus the WTP capacity required will be 2.76 MLD for 16 hours working. It is proposed to construct 2.76 MLD water Treatment Plant.

AERATION

Multiple tray type aerators shall be provided with central inlet with bell mouth opening at top and circumferential outlet constructed in RCC (M 20) with good architectural appearance. From outlet the water will flow to flow measurement unit through on RCC Channel. The loading rate should be from 0.15 to 0.45 m² /m³ /hr and the number of steps should not be less than 4 with 15-30 cm rise.

Flow Measurement in flume channel

The measurement of flow of raw water shall be done by float operated weather proof pedestal type open channel transmitter with level indicator complete with initial fitting of mercury resistance arrangement. Suitable sized float of suitable materials with non-corrodible float recording counter weight etc. and all necessary accessories shall be provided to measure discharge up to 5 MLD. This flume channel should be constructed with RCC M 20 concrete with side walkway (minimum 75 cm) of RCC.

This will have electrical transmission arrangement with remote type reading indicator 300 mm nominal dia. 270 scale indicator, and recorder to record the flow of water on 300 mm dia circular chart for 24 hours. This will be driven by synchronous motor of single phase 50 cycle 250 volts. Necessary chart required for a period of 6 months should be supplied free of cost.

Mixing Chamber (Flash mixer)

Flash mixer shall be provided with R.C.C. (M 20 Concrete) mixing chamber with electrically driven mixing arrangement of propeller type. Detention period shall be about 30 Seconds. Design of mixing chambers shall be of conventional type with height to diameter ratio 2:1 to 3:1 is preferred for proper dispersal. It shall have walking platform made up of RCC all around 75 cm wide with 3 no. of 25 mm G.I. pipes railing with 40 mm dia G.I. pipe posts at suitable intervals for proper inspection.

Electric motors as required shall be housed at proper place. Mixing chamber shall have necessary inlet and outlet chamber with adequate arrangements for cleaning the sludge deposits from the bottom of the chamber and to be finally discharged in the underground drainage system. Sludge clearance pipes shall be of cast iron of adequate size of not less than 200 mm dia with proper valve arrangements and whole works to be done as per CPHEEO manual.

CLARI-FLOCCULATOR

Flocculating Chamber

Clarifier shall be provided with flocculating chamber within it conforming to IS 7208-1974. Detention period of flocculator shall not be less than 30 minutes. There shall be adequate arrangements for proper flocculation (without having any dead zones) with necessary gentle moving paddles run by electric motors. The design of flocculating chamber, its shaft and paddle shall be of standard type as per CPHEEO manual and as finally approved by the DVC/ Consultant. Shaft shall be of stainless steel and paddles of good jamun or pinewood.

The flocculated water passes out from the bottom of the flocculation tank to clarifying zone through a wide opening. The area of the opening should be large enough to maintain a very low velocity 0.25 m/min under quiescent condition in the annular settling zone. The floc embedding the suspended particles settles to the bottom and cleared effluent overflow into the peripheral launder.

Clarifier

There shall be one unit of clarifier capable of clarifying 5 ML of coagulated water in 16 hours. The detention period shall not be less than 2.5 hours excluding the detention period in flocculating chamber. The surface loading shall be 45 Cum/Sqm/day and weir-loading rate shall not exceed 300 Cum/m/day. The outlet velocity of water from the flocculating chamber to the clarifier shall not be less than 0.25 m/minute. Depth of water near outer wall of the clarifier shall not be more than 3.6 meter. The dimensions and sizes of various units shall be as per standard practices and within limits fixed by the code of practices and CPHEEO manual. Suitable channel / Launder for collecting clarified water should be inside the clarifier all around.

Mechanical equipments

The clarifier shall be provided with mechanical scrapers, the velocity and movements of which shall be within the permissible limits as fixed by the CPHEEO manual on water supply and as approved by the DVC / Consultant.

The bottom of the clarifier shall have the adequate slope not flatter than 1:12 for efficient removal of the sludge into the sludge pit from where it shall be drained through underground drainage system. The mechanical scrapper and bridge with which they are fixed shall be of robust built and shall have M.S. checkered plates, walk way platforms and pipe railings for easy inspection, electric motors and their connections shall be done in such a manner that there is no change of electro leaking to main bridge. The Electro motor (always with one stand-bye) shall also be properly housed and covered by steel covers. The bridge shall be provided with steps at the outer end.

The central pivot bearing of the scrapper bridge shall be of best quality of Mild steel and the wheels on which the bridge moves round the periphery shall be of cast iron tyred with ½ “manganese frame steel ring all round”. The wheel will move on M.S. rails of not less than 24 lb/yard suitable and firmly fixed on the outer wall of the clarifier.

Reduction gears, bearings, motors, starter, switches etc. shall be of best quality and approved by the department before purchases are made.

Clarifier shall be provided with wind breaking screens of proper materials to be fixed about 0.45 meters inside the outlet weir to check disturbances of flow on weir by waves due to wind action.

Clarifier will have 1 meter R.C.C. walkway all round and with 25 mm G.I. pipe railings in three rows fixed in 40 mm G.I. pipe post, connected to different walkway for easy approach and Inspection of the setting units.

Inlet pipes coming from the Flash Mixer to the flocculator and sludge outlet pipes going out of the sludge pit shall be of C.I. of adequate size. Inlet and outlet connections from the Flash Mixer for removal sludge shall be of proper size of cast iron pipes.

Outlet chamber shall be connected with filter inlet channels with suitable size of D.I. pipes, Specials and valves for giving a bypass arrangement as per requirements.

SLUDGE REMOVAL

Sludge is removed under hydro-static pressure through the pipe. The size of the pipe will depend upon the flow and quantity of suspended matter. A telescopic sludge discharge arrangement for easy operation and for minimizing the wastage of water. Pipe diameter is preferred 100 mm to 200 mm dia.

RCC sludge well shall be constructed to collect sludge of all units at place between filter house and clariflocculator. It shall be of adequate size, depth and covered with R.C.C. slab R.C.C. Hume pipe of adequate size shall be laid from sludge well up to the place where sludge will be finally discharged. Provision of adequate number of inspection chambers and manholes shall be made as per requirements and as per the direction of Engineer-in-charge.

CHEMICAL HOUSE

Chemical house of 10m x 6m shall be double storied R.C.C. framed structure with sufficient floor space for storing chemicals, weighing arrangements etc. in the ground floor and accommodating different chemical mixing chambers in the first floor. The plinth level of the structure shall not be less than 60 cm from the finished ground level and ceiling height in both floors shall not be less than 3.60 meter. The panel wall in the ground floor shall be of 37.5 cm thickness and top floor single brick thickness of 25 cm. The chemical house shall be rectangular in shape.

Walkway passage of not less than 1.20 meter width suitable roof shall be provided from filter house to chemical house and also both side of the chemical house for loading to flash mixers near the clarifier. Walkway shall be of R.C.C. slab on R.C.C. column. There shall be 25 mm G.I. pipe railings in three rows fitted in 40 mm dia G.I. pipes post duly fixed in R,C,C. slab at 1.5 meter spacing on both sides of walkway.

Ground floor of chemical house shall be provided with 38mm thick patent stone flooring with damp proof arrangement. Chemical house shall be in two compartments in ground floor, one shall be for storage of materials and another shall work as lifting platform. Chemicals shall be lifted from this floor to upper floor by the help of hoists. The proper hoisting arrangement for lifting chemicals shall be provided.

The chemical house ground floor where alum and lime are to be stored shall be finished with acid and alkali resistant compound. The floor and wall of chemical mixing chambers shall have facing of acid and alkali proof tiles with proper corner and edge finishing as per

standard specification and practice. For lime tank walls and floor shall be of epoxy coating paint.

Roof of the chemical house shall be of R.C.C. slab and beam types. The inside surface of walls and ceiling shall be finished with plastic emulsion paints over and above as per standard specification and outside surface with 2 coats of snowcem with approved shade.

The chemical house shall be provided with a steel door and windows. A collapsible gate shall also be provided for bringing chemical in heavy loads in the chemical house.

Design should be based on gravity Chemical feed arrangements with necessary agitating equipments and R.C.C. mixing solution tanks. Tanks shall have the capacity for about 24 hours feeding and shall have proper glazed tiles lining around the floor and walls, Chemical tanks shall have dissolving trays of non-corroding and anti-rusting materials.

There shall be adequate arrangements for feeding the tanks with clean water and also for removing the sludge from the tank to underground drainage system.

There shall be 100% standby for chemical tanks. Each tank shall have suitable electrically driven agitators. The tanks shall be designed for not more than 5% solution strength.

Each tank shall be provided with mechanical water level indicator with proper scale fixed at convenient place. Separate arrangements shall be made for screening and staking of lime with proper arrangements for fume ducts.

All pipes and fittings dealing with flow of the chemical solution shall be of P.V.C. or equivalent materials and valves shall be of P.V.C. diaphragm type. Chemical room in the first floor shall be provided with not less than 6 Nos. of exhaust fan of 45 cm sweep. For lifting chemicals, two manually operated hoists shall be provided and fixed at suitable place in chemical house having arrangements of movement.

Two electrically operable grinders shall be provided for breaking the alum blocks to sizes 12 mm to 25 mm at the rate of 200 kg per hour.

One number mechanical weighing machine of 0.5 M.T. capacity of approved quality shall be provided for weighing the chemicals.

Two nos. lime tanks with electrically driven agitator pipes, lime-dosing arrangement etc. shall be provided.

FILTER BED AND FILTER HOUSE

The plant shall have 4 filter beds or as required with sufficient provision for backwashing with total 5 ML capacity in 16 hours and should be of suitable size. The filter beds shall be designed to give 5000 liters per hour / sq. m for normal loading, when filtered water shall have turbidity not exceeding 1 PPM. The beds shall be capable of overloading up to 25% with filtered water turbidity not exceeding 3 PPM.

Concrete walls, floors and rooms etc. shall be left with such joints as decided and approved by the department for future extension. Filter beds and filter house shall be constructed of R.C.C. M-20 grade concrete and the superstructure shall be a framed structure with paneling done by 1st class brickwork in cement mortar 1:4. All water-containing portion shall be of

R.C.C. of adequate thickness that shall not be less than 15 cm and all the concrete structure should be designed to fulfill the un cracked check condition as per IS code of water retaining structure i.e. IS 3370 (revised edition).

Filter manifolds and under drainage system shall conform to IS 8419 (Part II) latest edition and shall be of best materials of cast iron and with orifice or strainer as per standard practices and they shall be procured and used only after approval of the department. The contractors will design with arrangements of false bottom under drains.

Quality and depth of filter media shall be as per standard practices and shall be approved by the DVC / Consultant. Tenders shall submit the detailed specification of materials for approval. The gravel will be hard round, durable and will not contain any foreign materials.

The gravel will be thoroughly washed before loading into the filter beds. The effective size of sand will be between 0.45 mm to 0.70 mm and uniformity coefficient shall not be greater than 1.7 nor less than 1.3. The sand should be as per IS 8419 Part I (Latest edition) and will be washed after dumping into the filters by back washing. Procurement of sand will be only after the sample is approved.

FILTER SAND

Effective size 0.45 to 0.70 mm, uniformity coefficient not more than 1.7 nor less than 1.3 m to 0.7 m depth sand 0.45 m in depth, sand and gravel conforming to IS 8491 (1) - 77, backwash by air wash, standard appurtenances (to be specified) and as per CPHEEO manual

Valves for inlet and outlet, wash water etc. shall be of adequate size and of best quality and I.S.I. marked make from IVC / Kirloskar / L & T or equivalent as approved by DVC / consultant. Spacing and size of wash water gutters shall be as per standard practices and specification as per CPHEEO manual.

Filtration (FILTER PLANT)

Filtration is a physical and chemical process for separating suspended and colloidal impurities from water by passing through a porous bed, usually made of gravel and sand or other granular material. Three types of filters are commonly used.

Slow sand Filter –

It consists of a water tight basin containing a layer of sand 75 to 90 cm thick supported on a layer of gravel 20 to 30 cm thick. The gravel is underlain by a system of open joint under-drains which lead the water to a single point of outlet, where a device is generally located to control the rate of flow through the filter. The effective size of sand used is 0.2 to 0.3 mm and its uniformity coefficient is 2.0 to 3.0. The gravel is usually placed in 4 layers for a total depth of 30 cm graded from 2 to 45 mm. 30 to 40 cm long baked clay or concrete pipes are laid with open joints to form the under-drain system.

In operation the filter is filled with water to a depth of 1.0 to 1.5 m above the surface of the sand. The rate of filtration is usually 100 to 150 Lph per sqm and the maximum loss of head is 60 cm. When this head is reached, the filter is taken up for cleaning. The water is drained, the bed dried, and the surface scraped to a depth of 20 to 30 mm. The depth of sand is restored by addition of clean sand. A normal period of operation between cleanings may be about 6 weeks with the turbidity of the raw water not exceeding about 30 JTU. Continuous

coagulation is not to be used for slow sand filtration. Sometimes where water is clear initial dosing with alum is done to form the mat on the surface. The rate of flow is regulated by a rate controller on the effluent pipe. Slow sand filters are highly efficient in the removal of bacteria, nevertheless the water should be disinfected. Slow sand filters are suitable where the turbidity of raw water is below 50 JTU.

Rapid sand Filtration:

In the case of rapid gravity filters the water receives preparatory treatment prior to its application to the filter. The water that enters the filter contains flocs in which are entrapped suspended organic and mineral matters. The standard rate of filtration through a rapid sand filter is usually 80 to 100 Lpm 'm'. Practice is tending towards higher rates in conjunction with greater care in conditioning the water before filtration and with the use of coarser sand. A maximum area of 100 ml for a single unit of filter is recommended for plants of greater than 1000 mld consisting of two halves each of 50 sqm area. Also for flexibility of operation a minimum of 4 units should be provided which could be reduced to two for smaller plants. Where filters are located on both sides of a pipe gallery, the ratio of length to breadth of a filter box has been found to lie in a number of installations between 1.11 and 1.66, averaging about 1.25 to 1.33. A minimum overall depth of 2.6 m including a free board of 0.5 m is adopted. The filter shell may be in masonry or concrete to ensure a water tight structure. Except in locations where seasonal extremes of temperature are prevalent, it is not necessary to provide roofing over the filter, the operating gallery alone being roofed over. The effective size of filter sand shall be 0.45 to 0.70 mm and uniformity coefficient shall be neither more than 1.7 nor less than 1.3. The sand layer has a depth of 60 to 75 cm. The standing depth of water over filter varies between 1 and 2 m. The free board above the water level should be at least 50 cm to provide for an additional quantity of 15 to 30 cm depth of water to overcome air binding problems. The under-drainage system of the filter is intended to collect the filtered water and distribute the wash water uniformly. The most common type of under-drain is a central manifold with laterals either perforated on the bottom or having umbrella type strainer on top. The perforations vary from 5 to 12 mm in dia. The spacing of perforations vary from 8 cm for perforations of 5 mm to 20 cm for perforations of 12 mm. Ratio of total area of perforations to the entire filter area may be about 0.3 percent. The ratio of length to dia of lateral should not exceed 60. Spacing of laterals closely approximates the spacing of orifices and shall be 30 cm. The cross-sectional area of the manifold should be preferably 1.5 to 2 times the total area of laterals to minimize the frictional losses and to give best distribution, other types of under-drainage systems such as false bottom floors with nozzles, Porous slabs etc. are also used. For more details the 'Manual on Water Supply' may be referred to. Gravel is placed between the sand and under-drainage system to prevent sand from entering the under-drains and to aid uniform distribution of wash water. The gravel should accomplish both purposes without being displaced by the rising wash water. Sizes of gravel vary from 50 mm at the bottom to 2 to 5 mm at the top having 45 cm depth. The bottom of wash water gutters are placed 50 mm or more above the level of expanded sand. The troughs are designed as free falling weirs or spillways. Back wash is arranged at such a pressure that sand should expand to about 130 to 150 percent of its undisturbed volume. The pressure at which the wash water is applied is about 5 m head of water as measured in under-drains. Normal rate at which wash water is applied is 600 Lpm per sqm of filter surface equivalent to the rise in the filter box of 60 cm min for a period of 10 minutes. For high rate wash the pressure in the under-drainage system should be 6 to 8 m with the wash water requirement being 700 Lpm per sqm for duration of 6 to 10 min. Where air and water are used for backwashing the air may be forced through the under-drains before the wash water is introduced or through a separate piping system placed between the gravel and the sand layers. Free air of about 600 to 900

Lpm per sqm of the filter area at 0.35 kg cm² is forced through the under-drains for about 5 minutes following which wash water is introduced at a rate of 400 to 600 Lpm per sqm of area. The supply of wash water can be made through an overhead storage tank or by direct pumping. The capacity of the storage tank must be sufficient to supply wash water to two filter units at a time where the units are four or more.

R.C.C. Wash Water Tank

R.C.C. Wash water tank of required capacity and staging height as per standard norms of CPHEEO manual shall be provided at proper level. The height of the water tank shall be as per CPHEEO manual. 2 Nos. filter bed can be washed at a time for 12 minutes at 600 liter / m² under a head of 12 m from the filter sand bed

Necessary pipe assembly for rising, delivery, overflow and wash out mains with puddle collars, specials and valves arrangement of cast iron of adequate sizes shall be provided, suitable water level indicator and mosquito proof wire netting on the ventilating lantern should be provided.

Water will also be supplied to chemical house, chlorine house, pump house and administrative building, toilet and staff quarters.

Wash Water Pumps

Wash water pumps of suitable capacity to fill wash water tank in one hour with 100% stand by to be provided as per CPHEEO manual.

Chlorination

Proper space for housing the chlorinator shall be provided and the room shall be provided at suitable place. Space should also be provided for keeping chlorine cylinders and bleaching powder for a week. The chlorinator room shall be provided with sufficient exhaust fans and other safety arrangements. Provision for post and pre chlorination by chlorinators suitable for doing chlorination with chlorine gas shall be made. There shall be two chlorinators one acting and one as a stand by, sufficient to allow dosing of 3 PPM at full supply having the arrangements to increase the dosing at time of urgency. Arrangement for recording of dosing should also be provided.

Laboratory

A well equipped laboratory for physical, chemical and Bacteriological test as per WHO/CPHEEO manual to be provided in the filter House. The arrangement of sufficient furniture, Cupboard, testing equipments and refrigerator etc. shall be made for efficient functioning of laboratory. The list of equipments should be mentioned by the tenderers and its rate should be included during coating rates. At least following testing equipments are essential.

1. Turbidity rod-1 Number.
2. Photo electric turbidity meter with known standard samples – 1 Number (Nepheles meter – systronics type).
3. Residual chlorine compressor (up to 5 PPM dose / chloroscope).
4. pH testing metre – 1 Number.
5. Glassware and chemicals – 1 set (6 Number beakers of 500 ml each).

CLEAR WATER SUMP (RESERVOIR)

A R.C.C. clear water reservoir of ----- Cum capacity shall be constructed at the treatment plant site with M-20 Concrete. The shape of the sump shall be circular. Clear water reservoir shall have inlet channels connected with filter outlet channel. Walls of the reservoir and roof shall be of R.C.C. M-20 treated with two layers of tar felt over it and a layer of the tar painting in the ceiling.

There will be adequate number of ventilators suitably placed and provided with mosquito proof nettings. Proper surface drain shall be constructed around, which will ultimately be connected to the general drainage system. The top roof of the reservoir will have sufficient opening with C.I. vent pipes and cowl.

The whole structure shall be constructed of R.C.C. M-20 as per specification. The maximum depth of water in the clear water reservoir shall be 3.0 meter. The floor level is to be kept as high as possible in consistent with the filter outlet channels, which feed it. The reservoir bottom floor shall be provided with proper slope as to allow the entire water to be drained out at the time of its cleaning and washing.

Consideration of soil pressure from outside when reservoir is empty and up lift pressure of sub-soil water shall be taken into consideration in the design of the reservoir. ***Design of different units is to be done based on soil investigation duly approved by Consultant / DVC.***

All pipes and valves connected both in inlet and outlet chambers shall be of galvanized iron and cast iron respectively and also as per I.S. Specifications.

Two manholes with MS Iron frame and sheet made cover including locking arrangement on the top of the roof of sump.

PUMP HOUSE

The pump house shall be of adequate size and shall be located at suitable place by the side of clear water sump. It will also include dry pump pit. The pump pit shall be of adequate size to accommodate 4 number Pumping sets of suitable capacity each. The floor of pump pit shall not be deeper by more than 3.6 meter from ground level. 1.2 meter wide R.C.C. stair shall be provided on each side of the pump house for going down to the pump pit floor and also provided with 25 mm G.I. pipe railing in three rows fixed in R.C.C. Post on both side of the stair.

The walls of the pump chamber below plinth level shall be of R.C.C. The floor of entire pump chamber and walls shall be suitably designed to take the sub-soil water pressure & earth pressure. Walls below ground level shall be plastered with 12 mm thick cement plaster (1:3) with 3% water proofing compound. The out surface of wall below ground level shall have two layers of tar felt. The pump base shall be separately cast and 40 mm thick gap between the floor and the pump base shall be filled with tar felt or other suitable materials to check vibrations being transmitted to other part of the structure at the same time to prevent leakage of sub-soil water.

Manually operable 3 M.T. capacity Gantry crane with chain pulley block shall be provided in the pump house. The pump house shall be provided with mono rail girders and proper size rails for 3 M.T. Capacity crane. The alignment of the mono rail will be suitably designed to have proper lifting arrangement of mechanical / electrical equipment for repair / maintenance purpose.

The floor and walls up to the plinth level of the pump chamber shall have vitrous tiles of approved color and shade, properly finished and polished. Central platform and stairs going to pump pit shall also have vitrous tiles.

The brick wall shall be plastered with 12 mm thick (1:6) cement plaster inside and out side.

The inner surface of wall of the pump chambers shall be painted with plastic emulsion paint and outer surface with snowcem.

There shall be 1.20-meter wide walkway over R.C.C. columns from pump house to filter house at the same level at which walkway in filter house is provided for around the filter bed.

The pump chamber and filter house etc. all shall be kept well lighted and ventilated with natural light and excess of air through long glass panels and window as per approved drawing. The front will have glass cover where needed and have fine architectural look.

In nutshell, the water treatment plant should be so designed as to give neat modern look and pleasing architectural appearance, economical and efficient working

ELECTRIFICATION WORK

There shall be proper lighting arrangement inside and outside of all the buildings such as chemical house, filter house and pump house. Proper lighting arrangement shall also be made for clarifying units. Necessary provision for the CFL lamps, electric fans, main switches and wires etc. shall be made. The tenderer shall have to also furnish the building wise / unit wise details of electric works to be provided.

Pipeline Work

Relevant IS Codes

IS:3114	:	Code of practice for laying CI pipes
IS:5822	:	Code of practice for laying of welded steel for pipes
IS:7364	:	Plastic pipe work for potable water supply (part I – III)

General Specifications for CI Pipeline Work

Cast Iron Pipe and Specials

1. All CI Pipes and specials supplied for this contract shall confirm to the following specifications:
IS 1536 - 1976 Specification for centrifugal cast (Spun) iron pressure pipes for water, gas and sewage.
IS 1538 - 1976 (Part V) Specification for cast iron fittings for pressure pipes.

Wherever reference is made for Indian Standard Specification the latest specification is applied.

2. All cast iron pipes supplied shall confirm to class LA of Indian Standard specifications. The work test pressure and the hydrostatic test pressure shall be as follows:

Hydrostatic Test pressure at works 3.5 N/mm² (35 kg/sq.cm.)

Hydrostatic test pressure after installation 1.2 N/mm² (12 kg/sq.cm.) All pipes to be supplied in this contract shall have SBR quantity rubber gaskets rubber tyton joints as per BIS 5282, 12820 with the spigot end suitably chamfered for smooth entry of pipe in the socket fitted with SBR quality rubber gasket. Care shall be taken to ensure that fittings fit easily into this pipe.

Each pipe shall be coated in accordance to Indian Standard specification. All pipe shall be marked as under:

Manufacturer's name or identification mark

The Nominal Diameter

Class Reference

Mass of pipe

The number of this Indian Standard and

The last two digits of the year of manufacture.

Cast Iron fittings

All cast iron fittings supplied shall confirm to heavy class of IS:1538, Part 1 to 23. The work of Test pressure and Hydrostatic test pressure shall be as follow:

Test Pressure

300 mm to 600 mm 2.5 N/sq.mm (25 kg/sq.cm)

600 mm to 1200 mm 1.0 N/sq.mm (10 kg/sq.cm)

Where non standard fittings are required in special locations, this shall be supplied of steel of minimum plate thickness of 6 mm and fabricated as per drawings and directions of Engineer-in-charge. These mild steel fittings will be specially protected against corrosion with painting as shown on drawing.

All Standard fittings marked as under:
Manufacturer's name or identification mark,
The Nominal Diameter,
Class Reference,
Mass of pipe,
The Number of this Indian Standard, and
The last two digits of the year of manufacturer.

Specification for Laying, Jointing & Testing of CI Rising Main

Stacking

The pipes and specials shall be handled with sufficient care to avoid damage to them. These shall be lined up on one side of the alignment of the trench, socket facing uphill or in the direction of flow of water.

Trench For CI Pipes and Specials

The trenches for the pipes shall be excavated to lines and levels as directed. The bed of the trench shall have to be truly and evenly dressed throughout from one change of grade to next. The gradient is to be set out by means of bonning rods and the required depth is excavated at any point. The depth of the trench shall not be less than 1 meter measured from the top of the pipe to the surface of the ground under roads crossing and not less than 0.75m elsewhere.

The width of the trench shall be the nominal diameter of the pipe plus 40 cm. but it shall not be less than 60 cm. in case of all kinds of soils excluding rock and not less than 55 cm. in case of rock. The bed of the trench, if in soft or made up earth, shall be well watered and rammed before laying the pipes and the depressions if any shall be properly filled with earth and consolidated in 20 cm. layers. If the rock is met with, it shall be removed to 15 cm. below the level of the pipe and the trench will be refilled with excavated materials and consolidated to the required grade.

The excavated materials shall not be placed within 1 meter or half of the depth of the trench whichever is greater from the edge of the trench.

The materials excavated shall be separated and stacked so that in refilling they may be re-laid and compacted in the same order to the satisfaction of the AVSLC. The trench shall be kept free of water. Shoring and Timbering shall be provided wherever required. Excavation below water table shall be done after dewatering the trenches.

After the excavation of the trench is completed, hollows shall be cut at the required positions to receive the sockets of the pipes and these hollows shall be sufficient depth to ensure that the barrels of the pipes shall rest throughout their entire length on the solid ground and that sufficient spaces left for jointing to underside of the pipe joint. These socket holes shall be refilled with sand after jointing the pipe.

All types of pipes water mains, cables, etc. met within the course of excavation shall be carefully protected and supported. Care shall be taken not to disturb the electrical and communication cables.

Laying of Pipes and Specials

Before being laid the pipes shall be examined to see that there are no cracks or defects. The cracked or defective pipes shall be summarily rejected. The pipes shall be thoroughly

cleaned of all dust and dirt and special care shall be taken to clean the inside of the socket and outside of the spigots.

The pipes shall be lowered into the trench by means of suitable pulley blocks, sheet legs, chains ropes etc. In no case the pipes shall be rolled and dropped into the trench. After lowering, the pipes shall be arranged so that the spigot of one pipe shall be carefully centered into the socket of the next pipe, and pushed to the full distance that it can go. The pipeline shall be laid to the levels required. Specials shall also be laid in their proper position as stated above. For pipe bedding PCC of grade M10 shall be used for which payment shall be done as per PCC 1:3:6 item of work.

Where so directed, the pipes and specials may be laid on masonry or concrete pillars. The pipe laid on the level ground shall be laid with socket facing the direction of the flow of water. In all other cases, the sockets shall be laid facing up hill.

Any deviation either in plan or elevation less than $11\frac{1}{4}$ degree shall be effected by laying the straight pipes round a flat curve, of such radius that minimum thickness of lead at the face of the socket shall not be reduced below 6 mm. or the opening between spigot and socket increased beyond 12 mm at any point. A deviation of about $2\frac{1}{4}$ degree can be affected at each joint in this way. At the end of each day's work, the last pipe laid shall have its open ends securely closed with a wooden plug to prevent entry of water, soil, rats and any other foreign matter into the pipe.

Cement concrete thrust blocks of suitable design as approved by the Owner/ Consultants shall be provided at 45 degree and 90 degree bands of the pipes and also at places where there is likelihood of thrust so as to withstand the dynamic and static forces developed due to water in the pipe line. The thrust blocks shall be made after the joints have been made.

Jointing

Jointing shall be carried out using approved quality rubber rings.

Testing of Joints

After laying and jointing, the pipes and fittings shall be inspected under working conditions of pressure and flow. Any joint found leaking shall be redone and all leaking pipes removed and replaced without extra cost. For hydraulic tests, all pipes shall be kept under test for 15sec at works and shall withstand hydrostatic test pressure as specified in BIS 1536/1989. The pipes shall be slowly and carefully charged with water allowing all air to escape and avoiding all shock or water hammer.

The draw off takes and stopcocks shall then be closed and specified hydraulic pressure shall be applied gradually. Pressure gauge must be accurate and preferably should have been recalibrate before the test. The test pump having been stopped the test pressure should maintain without loss for at least half an hour. The pipes and fittings shall be tested in sections as the work of laying proceeds, keeping the joints exposed for inspection during the testing.

Backfilling

The trenches prepared for laying of pipes shall be backfilled as described under Chap. 2.

MSERW Pipes

1. Supply of Material:-

(a)- General requirement relating to the supply of line pipes shall be as given in IS: 1387- 1967 and IS 1978 – 1982.

(b)- The steel used for the manufacture of pipes shall be made by open hearth, electric furnace, basic oxygen or a combination of these processes.

2- Grades: - Line pipes shall be of the following types and grades:-

Type of Pipes	Grade Designation
Seamless, electric welded	Y 170, YSt 210, YSt 240
Submerged arc welded	YSt 210, YSt 240
Butt welded	YSt 170

3- Formation: - Before Pipeline is laid, proper formation shall be prepared. For buried pipe line, suitable trenches should be excavated; pipe line above ground may be laid in cutting or on embankments or be supported by pillars as the case may be.

(a)- The trench shall be so dug that the pipe may be laid to the required alignment and at required depth. When the pipe line is under a roadway, a minimum cover of 1.0 m is recommended, but it may be modified to suit local conditions by taking necessary precautions. The trench shall be shored, wherever necessary, and kept dry so that the workman may work therein safely, and efficiently. The discharge of the trench dewatering pumps shall be conveyed either to drainage channels or to natural drains and shall be allowed to be spread in the vicinity of the worksite.

(b)- When welding is to be carried out with the pipe in the trench, additional excavation of not more than 600 mm in depth and 900 mm in length should be provided all round the pipe at the position of the joints for facilities of welding.

4- Welding: - The welding of pipes in field should comply with IS 816: 1969. Electrode used for welding should comply with IS 814 : 1991. The welded shall be tested in accordance with procedure laid down in IS 3600 part 1: 1985.

Pipe line jointing shall be done with electric arc welding or using approved quality of welding electric rod of 08 nos. & 10 nos. for different layers in proper manner and making necessary arrangements for generator and welding machine with all its necessary accessories as welding leads, chain-pulley, cylinder of oxygen and acetylene gas, fuel including supply and cartage upto

site of works and testing of the pipe line and its joint and completing all its respective works as per satisfaction of Engineer Incharge

- 5- **Pipe Laying:** - Before the pipe is lowered, the trench shall be carefully examined to determine that an even bedding is provided for the pipeline and that the pipe may be lowered into it without damaging the coating.

The procedure for lowering varies with the method adopted for coating the pipeline. Where the coating is to be done in the trench, the pipe may be lowered in the trench on supports sufficiently high so as to facilitate out- coating. The pipe should be lowered progressively with the help of shear legs or cranes using wide belts or slings. In case of coated pipes, extra care shall be taken to preserve the coating while lowering. Slings may be removed progressively without necessity of digging under the pipe. Where the trench is sheeted, the pipes shall be lowered into the trench by removing at a time, one or two struts only, care being taken to see that no part of the shoring is disturbed or damaged. If necessary, additional struts may be fixed during lowering, after the pipe is lowered, it shall be laid in correct line and level by use of leveling instruments, sight rails, theodolites, etc. Care shall be taken to see that the longitudinal joints of the consecutive pipes are staggered by at least 30° and should be kept in upper third of the pipeline, if there are two longitudinal joints they should be on the sides. While assembling the pipe faces shall be brought close enough to leave a uniform gap not exceeding 3 mm. The spiders from inside and tightening rings from outside from outside or other suitable equipment should be used to keep the two faces in shape and positions till at least one run of welding is carried out.

The pipes faces shall first be tack- welded alternately at one or more diametrically opposite pairs of points. After completing tack welding, full welding shall be carried out in suitable runs following a sequence of welding portions of segments diametrically opposite.

Backfilling should closely follow the welding of joints of the pipes, so that the protective coating should not be subsequently damage. Material harmful to the pipe line shall not be used for back filling. Refilling shall be done in layers not exceeding 300 mm. Each layer shall be consolidated by watering and ramming, care being taken to prevent damage to the pipe line. The filling on the two sides of pipe line should be carried out simultaneously.

- 6- **Test of Pipe Line:** - Before putting the line in to commission the welded pipe line shall be tested both for its strength and leakage by conducting Pressure test.

The pipe shall be free from the following defect-

- a) Dents - The pipe wall shall contain no dents deeper than 6.3 mm measured as the gap between the lowest point of the dent and a prolongation of the original contour of the pipe. The length of the dent in any direction shall not exceed one half the pipe diameter. All cold – formed dents deeper than 3mm with a sharp bottom gauge shall be considered injurious. The gauge may be removed by grinding;
- b) Offset of plate edges – The radial offset (misalignment) of plate edges in the weld seams shall not be greater than 1.6mm for submerged arc welded pipe. For electric – welded pipe the radial offset of plate edges plus flash trim shall not be greater than 1.5mm:
- c) Misalignment of weld seam in submerged arc welded pipe - Misalignment of the weld seam (off – seam weld)shall not be a cause for rejection provided complete penetration and complete fusion have been achieved as indicated by non – destructive examination:

- d) Height of outside weld bead - The outside weld bead shall not extend above the prolongation of the original surface of the pipe more than the amount listed below

Wall thickness,	Maximum height of wild bead,
mm	mm
12.70 and under	3.0
Over 12.70	4.5

Outside weld beads which are higher than permitted by the requirements of the clause may be ground to acceptable limit at the option of the manufacturer:

- e) Height of inside weld bead – The inside weld bead (flash) of electric welded pipe shall not extend above the prolongation of the original inside surface of the pipe by more than 1.5mm
- f) Trim of inside weld bead – The depth of groove resulting from removal of internal weld bead (flash) of electric weld pipe shall not be greater than the amount listed below:

Wall thickness (t),	Maximum depth of trim,
mm	mm
3.8 and less	0.10t
3.9 to 7.5	0.4 mm
7.6 and more	0.05t

Depth of groove is defined as the difference between the wall thicknesses measured approximate 25 mm from the weld line and the remaining wall under the groove.

- g) Grinding –When surface conditioning by grinding is performance it shall be done in a workmanlike manner.
- h) Hard spots – The surface of welded pipe in sizes 508 mm out side diameter shall be examined visually to detect irregularities the curvature of the pipe. When this examination fails disclose mechanical damage as the cause of an irregular surface but instead indicates that the irregular surface may be attribute to a hard spot, the hardness of the area in question shall determined. If the hardness is 35 Rockwell C (327 Brinell) harder and the dimension of the hardened area is greater the 50 mm in any direction, the section of the pipe containing hard spit shall be removed as a cylinder.

Galvanized Mild Steel (GI) Pipes

The pipes shall be galvanized mild steel welded pipes and seamless screwed and sockets tubes conforming to the requirements of IS.1239, for medium grade. These shall be of the diameter (nominal bore) approved. The sockets shall be designated by the respective nominal bores of the pipes for which they are intended. The pipes and sockets shall be finished neatly, well galvanized on both inner and outer surfaces, and shall be free from cracks, surface flaws, laminations and other defects. All screws, threads shall be clean and well cut. The ends shall be cut cleanly and square with the axis of the tube.

All screwed tubes and sockets shall have pipe threads conforming to the requirements of IS.554. Screwed tubes shall have taper threads while the sockets shall have parallel threads.

The fittings shall be of malleable cast iron or mild steel tubes complying with all the appropriate requirements as approved for pipes. The fittings shall be designated by the respective nominal bores of the pipes for which they are intended. The fittings shall have screw threads at the ends conforming to the requirements of IS.554. Female threads on fittings shall be parallel and male threads (except on running nipples and collars of unions) shall be tapered.

The pipes and fittings shall be inspected at site before use to ascertain that they conform to the specification. The defective pipes shall be rejected. Where the pipes have to be cut or re-threaded, the ends shall be carefully filled out so that no obstruction to bore is offered. The ends of the pipes shall then be threaded conforming to the requirements of IS.554 with pipe dies and taps carefully in such a manner as will not result in slackness of joints when the two piece are screwed together. The taps and dies shall be used only for straightening bent and damaged screw threads and shall not be used for turning of the threads so as to make them slack, water tight joint. The screw thread of pipes and fitting shall be protected from damage until they are fitted.

The pipes shall be cleaned and cleared of all foreign matter before being laid. In jointing the pipes, the inside of the socket and the screwed end of the pipes shall be oiled and rubbed over with white lead and few turns of spun yarn wrapped around the screwed end of the pipe. The end shall then be screwed in the socket, tee, etc, with the pipe wrench. Care should be taken that all pipes and fittings are properly jointed so as to make the joints completely water tight and pipes are kept at all times free from dust and dirt during fixing. Burrs from the joint shall be removed after screwing. After laying, the open ends of the pipes shall be temporarily plugged to prevent access of soil or any other foreign matter.

Any threads exposed after jointing shall be painted or in the case of underground piping thickly coated with approved anticorrosive paint to prevent corrosion.

For internal work the galvanized iron pipes and fittings shall run on the surface of the walls or ceiling (not in chase) unless otherwise specified. The fixing shall be done by means of standard pattern holder bat clamps. Keeping the pipe about 1.5 cm clear of the wall, Pipes and fittings shall be fixed truly vertical/horizontal. When it is found necessary to conceal the pipes, chasing may be adopted or pipes fixed in the ducts of recesses etc, provided there is sufficient space to work on the pipes with the usual tools. The pipes shall not ordinarily be buried in walls or solids floors. Where unavoidable, pipes may be buried for short distances provided adequate protection is given against damage, but the joints in pipes shall not be buried MS pipe sleeve shall be fixed at a place where a pipe is passing through a wall of floor for reception of the pipe and to allow freedom for expansion/contraction and other

movements maintenance. In case the pipe is embedded in walls or floors it should be painted with anti-corrosive bitumastic paint of approved quality. The pipe should not come in contact with lime mortar or lime concrete as the pipe is affected by lime. Under the floors the pipes shall be laid in layer of sand filling or as approved by the Project-in-Charge.

GI pipes with socket and spigot ends shall be provided with lead caulked joints wherever specified and the joints shall conform to the requirements of IS:3114.

The work of excavation and backfilling shall be done true to line and gradient in accordance with general Employer's requirements for earthworks in trenches for pipes laid underground.

PVC pipes shall be laid on a layer of 10.0 cm sand and sand filled upto 15 cm above the pipes. A sand cushion of 15 cm on either side of the pipe shall also be provided. The remaining portion of the trench shall then be filled with excavated earth. The surplus earth shall be got rid of as directed. When excavation is done in rock the bottom shall be cut deep enough to permit the pipes to be laid on a cushion of sand 75 mm minimum.

The pipes and fittings after they are laid and jointed shall be subjected to hydrostatic pressure test as approved by the Project-in-Charge and shall satisfactorily pass the test. Pipeline system shall be tested in sections as the work proceeds, keeping the joints exposed for inspection. Pipes shall be slowly and carefully charged with water allowing all air to escape. All draw-off taps shall then be closed and water pressure gradually raised to test pressure. Care shall be taken to ensure that pressure gauge is accurate and preferably should have been recalibrated before the test. Pump used having been stopped the section of the pipeline shall maintain the test pressure for at least half an hour. Any joints or pipes found leaking should be removed and replaced by the Contractor.

The GI pipeline shall be cut to the required length at the position where the meter and stopcock are required to be fixed. The ends of the pipes shall be threaded. The meter and stopcock shall be fixed in position by means of connecting pipe, G.I nuts, sockets, etc. The stopcock shall be fixed near the inlet of the water meter. The paper disc inserted in the ripples of the meter shall be removed and meter installed exactly horizontally or vertically and with the arrow cast on the body of the meter pointing in the direction of flow. Care shall be taken that the factory seal of the meter is not disturbed. Whenever the meter is to be fixed to a newly fitted pipeline, the pipeline will have to be completely washed before fixing the meter. For the purpose, a connecting piece of pipe equal to the length of the meter is to be fixed on the new pipeline. The water shall be allowed to flow completely to wash the pipeline and then the meter installed as described above by replacing the connecting piece.

Cast Iron Soil Waste and Vent Pipes and Fittings

All cast iron pipes and fittings shall be of uniform thickness with strong and deep sockets, free from flaws, air holes, cracks, sand holes and other defects and conform to IS:1536. The diameter approved shall be internal diameter of pipe. The pipe and fittings shall be true to shape, smooth and cylindrical and shall ring clearly when struck over with a light hand hammer. All pipes and fittings shall be properly cleaned of all foreign materials before being fixed.

All plug bends of drainage pipes shall be provided with inspection and cleaning caps, covers, which shall be fixed with nuts and screws. Pipes shall be fixed to the wall by W.I or

MS holder bat clamps unless projecting ears with fixing holes are provided at socket end of pipe. The pipes shall be installed, truly vertical or to the lines and slopes as indicated. The clamps shall be fixed to the walls by embedding their hooks in cement concrete blocks (1:2:4) 10 cm x 10 cm making necessary holes in the walls at proper places. All holes and breakage shall be made good. The clamps shall be kept 25 mm clear of the finished face of the walls to facilitate cleaning and painting of pipes.

The annular space between the socket and spigot shall be filled with a gasket of hemp or spun yarn soaked in neat cement slurry. The joint shall then be filled with stiff cement mortar 1:2 (1 cement : 2 fine sand) well pressed with caulking tool and finished smooth on top at an angle of 45 °. The joint shall be kept wet for not less than 7 days by tying a piece of gunny bag kept moist. Joints shall be perfectly air tight as well as water tight.

C.I pipes and fittings which are exposed shall be first cleaned and then painted with a coat of red lead primer. Two coats of zinc paint with white base and mixed with pigment of required colour to get the approved shade shall be given over the base primer coat.

The thickness of fittings and their socket and spigot dimensions shall conform to the thickness and dimension approved for the corresponding sizes of straight pipes.

The connection between the main pipe and branch pipes shall be made by using branches and bends with access for cleaning. Floor traps shall be provided with 25 mm Dia. Puff pipe where the length of the waste is more than 1800mm or the floor trap is connected to a waste stack through bends.

All cast iron pipes and fittings including joints shall be tested by a smoke test to the satisfaction of the Engineer-in-charge and left in working condition after completion. The smoke test shall be carried out as stated under:

Smoke shall be pumped into the pipe at the lowest and from a smoke machine, which consists of a bellow and a burner. The material usually burnt is greasy cotton waste, which gives out a clear pungent smoke which is easily detectable by sight as well as by smell if there is a leak at any point of the pipeline.

Water test and air test shall be conducted as stipulated in IS: 5329

Asbestos Cement Pipes and Fittings

All Asbestos Cement (AC) soil, waste, vent pipes, and fittings shall conform to IS 1626. The pipes shall have spigot and socket ends. These shall be composed of an inert aggregate consisting of clean asbestos fiber cemented together by ordinary Portland cement conforming to IS:269, or Portland blast furnace slag cement conforming to IS.455. No organic material shall be added to the composition.

The pipes shall be straight and the ends of the pipes and fittings shall be finished square to their axes. The finished pipes and fittings shall be true and smooth, their inner and outer surfaces shall be concentric. They shall be in all respects sound, homogenous and free from impurities or other imperfections.

The permissible tolerance on the thickness and external dimensions of pipes and fittings including hydraulic test pressure of the pipes and fittings shall conform to IS.1626.

All AC pipes and fittings shall be of approved make and with necessary accessories, wherever required. The diameter wherever approved for pipes and fittings shall be clear internal diameter. All gaps between pipes and fittings and walls shall be filled with cement mortar 1:3 neatly finished. All pipes and fittings shall be supported with standard fixing brackets.

The annular space between the socket and spigot shall be filled with a gasket of hemp and spun yarn soaked in tar. The joint shall then be filled with stiff cement mortar 1:2 (1 cement: 2 fine sand) well pressed with caulking tools and finished smooth on top with neat cement paste at an angle of 45°. The joint shall be kept wet for not less than 7 days by typing a piece of gunny bag kept moist. Joint shall be perfectly airtight as well as watertight.

Pipes and fittings shall be tested with a smoke test as approved.

Stoneware pipe and fittings

All pipes with spigot and socket ends shall conform to IS.651/3006 and shall be of grade 'A'. These shall be sound, free from visible defects such as fine cracks or hair cracks. The glaze of the pipes shall be free from crazing. The pipes shall give a sharp clear note when struck with a light hammer.

The following information shall be clearly marked on each pipe and fitting:

Internal diameter

Grade

Date of manufacture;

Name of manufacture or his registered trade-mark or both

All pipes and fittings shall have ISI mark jointing of GSW pipes and fittings shall be done as per the requirements of the following Employer's Requirements and the relevant IS. After jointing, extraneous material if any, shall be removed from the inside of the pipes and fittings and the newly made joints shall be thoroughly cured. In case, rubber sealing rings are used for jointing, these shall conform to IS:5382.

Spigot and Socket Joint (Cement Joint)

The Spigot of each pipe shall be slipped home well into the socket of the pipe previously laid and adjusted in the correct position. In each joint, spun yarn soaked in neat cement slurry or tarred gasket shall be passed around the joint and inserted in it by means of caulking tool. More skeins of yarn or gasket shall be added if necessary and shall be well caulked. Yarn or gasket so rammed shall not occupy more than one fourth of the depth or socket.

Cement mortar (1:1) shall be slightly moistened and carefully inserted by hand into the remaining space of the joint after caulking of yarn or gasket. The mortar shall then be caulked into the joint with a caulking tool. More cement mortar shall be added until the space of joint has been completely filled with tightly caulked mortar. The joint shall then be finished off neatly outside the socket at an angle of 45 degrees.

The cement mortar joints shall be cured at least for seven days before testing.

Spigot and Socket Joint (Rubber Ring Joint)

The pipe with the rubber ring accurately positioned on the spigot shall be pushed well home into the socket of the previously laid pipe by means of uniformly applied pressure with the aid of a jack or similar appliance. The rubber rings conforming to IS: 5382 shall be used and the manufacturer's instructions shall be deemed to form a part of this Employer's Requirements. The rubber rings shall be lubricated before making the joint and the lubricant shall be soft soap water or an approved lubricant supplied by the manufacturer.

Cleaning of Pipes

As soon as a stretch of GSW pipes has been laid complete from manhole to manhole or for a length as approved by the Engineer-in-charge, the Contractor shall run through the pipes both backward and forward a double disc or solid or closed cylinder 50 mm less in diameter than the internal diameter of pipes. The open end of an incomplete stretch of pipeline shall be securely closed as approved by the Engineer-in-charge to prevent entry of mud or silt etc.

If as a result of the removal of any obstruction the Engineer-in-charge considers that damage may have been caused to the pipelines, he shall be entitled to order the length to be tested immediately. Should such a test prove unsatisfactory the Contractor shall repair the pipeline and carry out such further tests as are required by the Engineer-in-charge.

It shall also be ascertained by the Contractor that each length from manhole to manhole or the length as approved by the Engineer-in-charge is absolutely clear and without any obstruction by means of visual examination of the interior of the pipeline suitably illuminated by projected sunlight or otherwise.

Testing at Work Site

After laying and jointing of GSW pipes is completed the pipeline shall be tested as per the following Employer's Requirements and as approved by the Engineer-in-charge. All equipment for testing at work site shall be supplied and erected by the Contractor. Potable water for testing of pipeline shall be arranged by him. Damage during testing shall be the Contractor's responsibility and shall be rectified by him to the full satisfaction of the Engineer-in-charge. Water used for test shall be removed from pipes and not released to the excavated trenches.

After the joints have thoroughly set and have been checked by the Engineer-in-charge and before backfilling the trenches, the entire section of the sewer or storm water drain shall be proved by the Contractor to be water tight. Before commencing the hydraulic test, the pipelines shall be filled with water and maintained full for 24 hours by adding water. If necessary, under a head of 0.6 m of water. The test shall be carried out by suitably plugging the low end of the drain and the ends of connections, if any, and filling the system with water. A knuckle bend shall be temporarily jointed at the top end and a sufficient length of vertical pipe jointed to it so as to provide the required test head, or the top end may be plugged with a connection to a hose ending in a funnel which could be raised or lowered till the required head is obtained and fixed suitably for observation. The pipeline shall be subjected to a test pressure of at least 2.5 m head of water at the highest point of the section under test. The leakage tolerance of two litres per centimeter of diameter per kilometer may be allowed during a period of 10 minutes. Any leakage including excessive sweating which causes a drop in the test water level will be visible and the defective part of the work should be removed and made good.

If any damage is caused to the pipeline during the execution of work or while cleaning/testing the pipeline as specified, the Contractor shall be held responsible for the

same and shall replace the damaged pipeline and re-test the same to the full satisfaction of the Engineer-in-charge.

Water for testing of pipeline shall be arranged by the Contractor.

Stop Cock and Bib Cock

Stopcocks and Bibcocks shall be of brass heavy class, chromium plated and of approved manufacture and pattern complying with IS: 781. They shall be of specified size and of the screw down type. The cocks shall open in anti-clockwise direction and chromium plating shall be done in accordance with IS: 1068.

Valves

Types of Valve and Meters

Each filter bed shall be provided with meters for head loss, filter discharge recorders, flow controller, total discharge meter from the filter bed and hydraulically operable sluice valves, penstock of adequate size and dimension of approved quality. Each filter bed shall have separate control table for accommodating operating knobs and switches of these meters and valves. Alternative arrangements of mechanical operation of important valves should also be made. There shall be a wash water controller installed at a suitable place to regulate the flow of water coming into the bed. A suitable indicating dial type meter for reading the flow should be provided and fixed. There shall be adequate arrangements for disposal of wash water from the filter beds through C.I. pipes and drains connected with general system of underground drainage. Care shall be taken not to have common wall between the wash water drain or pipes and pure water channel.

Pure water channel shall be of adequate size and totally covered from all sides with manhole and heavy glass covered for cleaning arrangement. All precautions shall be taken to avoid contamination and fouling of pure water.

Clear water channel shall be lined on sides and bottom with white glazed tiles. Suitable pit about 3 m deep lined with white glazed tiles on sides and bottom and having thick glass cover shall be constructed at proper and well lighted place to see the clarity of water with naked eyes. All works to be done as per CPHEEO manual.

For air wash rotary air type blowers capable of delivering 600 LMP per square meter of free air of filter area 0.4 kg per square cm at the under drains having 100% stand by including auto transformer, starters, main switches and pipe connection etc. all complete shall be provided.

Pipe gallery shall be of proper width, adequate length and depth to accommodate different pipe systems for efficient working of the filtration plant. Discharge of wash water inlet and outlet pipes and channels etc., pipes and valves shall be so arranged as to have easy access for working and for repair in case of need in future. Walking platform of not less than 1.2 m width which shall be made through out the length and connected to the nearby pump house and chemical house, which shall be covered with R.C.C. roofs.

There shall be 1.20 mt. wide R.C.C. stairs with kota stone rises and treads having 75 cm high G.I. pipe railings in three rows fixed in R.C.C. Post for access into the operating platform from the top of clear water channel. Provision shall be made for aluminum ladder with side railing for access into pipe gallery from top of clear water channel, Walls, Floor, Stapes of the filter operating platform and walls walk ways in between the filters shall all be provided with vitreous tiles with approved quality and shade.

There shall be 75 cm wide walkway around the filter beds with 75 cm high, 25 mm G.I. pipe railing in three rows fitted in 40 mm G.I. pipe railing post. There shall be 40 mm wide and 25 mm high beat on the edge of filter beds to prevent debris and dust falling into the beds during cleaning of floor.

Inner walls and ceiling of the filter house shall be painted with plastic emulsion paints over plaster of paris as per standard specifications and the outer surface of the wall shall have 2

coats of snowcem painting of approved shade. Over cement plaster 12 mm thick 1:4 cement mortar.

Adequate skylight and window shall be provided in the filter house to admit sufficient natural light. All the window and doors shall be provided with double layer of mosquito proof netting in addition to the thick glass panels. The netting shall be separately fixed with teak wood framing.

General Specifications for Valves

Gate (Sluice) Valves

Gate Valves shall be either solid wedge or knife gates unless specifically defined on the drawings.

Solid Wedge Gate-Type Sluice Valves

General

All valves shall be double-flanged. Valves of Indian manufacture and in the size ranging 50mm to 300mm shall conform to BIS 780 and those of size ranging from 350 mm and larger to BIS:2906. Imported valves shall conform to the relevant British or American Standards. The materials used in construction, the design and all other relevant features shall be such that the valves are entirely suitable for use on sewer/sludge pipelines, force mains and within sewage pumping stations. Valve shall be of suitable pressure rating which shall not be less than twice the normal operating pressure. PN rating

For duty heads below 100 m – PN1.0

For duty heads above 100 m – PN1.6

Design

The design of the valves will be such that erosion, cavitation, vibration and head loss (in the fully open position) shall be a minimum external lubrication. The valves should be capable of being opened and closed against working pressure which exceed the maximum working pressures by 15 percent.

Materials

The materials used for the manufacture of each component shall be the best available for the specific purpose and shall not, in any case be inferior to the following:

Cast Iron	:	BIS. 210 Grade 20
Stainless Steel	:	BIS. 1570 Grade, BS 970 Type EN, ASTM A 473.
Gun Metal	:	BIS.1400-LG 2 -C or the equivalent Indian Std.
Cast Steel	:	Plain Carbon Steel complying with BIS. 1570 Grade, or BS: 970 Grade 431 S 29.

Valve Bodies

a. Castings

The structure of the castings shall be homogeneous and free from non-metallic inclusions and other injurious defects. All surfaces of castings, which are not machined shall be smooth and shall be carefully fettled to remove all foundry irregularities.

b. Forgings

All major stress bearing forgings shall be made to a standard specification, which shall be submitted if required to the Engineer-in-charge for approval before work is commenced. Forging shall be subjected to non-destructive tests to detect flaws if any. Forging shall be heat treated for the relief of residual stresses. The name of the maker and particulars of the

heat treatment proposed for such forging shall be submitted to the AVSLC. The Engineer-in-charge or his inspector may inspect such forging at the place of manufacture with a representative of the Contractor.

c. Workmanship

Workmanship and general finish shall be of first class commercial quality and in accordance with best workshop practice.

All similar items of the valve and their component parts shall be completely interchangeable. Spare parts shall be manufactured from the same materials as the originals and shall fit in place of all similar items.

All parts, which can be worn or damaged by dust shall be totally enclosed in dust proof housings.

Protective coating shall comply with BS 1218 Clause 16, for use in tropics, or BIS 2906, Clause 7.

Spindle Details

The spindles shall be of Bronze and to permit the solid wedge gate to be so raised as to permit an unimpeded flow passage through the valve in open position. Where hand wheels are provided the direction of rotation and the words 'OPEN' shall be marked prominently on the upper side. All spindles contacting surfaces in the valve body shall be bushed with gunmetal.

Valve Gates

Each face of the gate shall be lined with heavy gunmetal rings, which will match with corresponding rings in the body. The rings shall be force fitted by special fixtures and riveted in the case of valves in the size range 450 mm and larger. When finally assembled, the body and wedge faces shall provide a watertight bearing surface. When shut, the gates shall ride on the body seats, to allow for wear.

Operation

The tops of the spindles or gears operated with extension spindles or tee keys shall be provided with caps of dimensions conforming to BIS 2906 Table III. The direction of opening shall be indicated on the caps.

Lubrication

At the points where lubrication is needed the Contractor shall furnish full details of the method to be employed. The requirement of the requisite lubricating equipment and lubricants for commissioning and operating and maintaining the valves for one year shall be furnished by the contractor.

Spare Parts

One spare spindle and nut shall be supplied under this contract for each group of 10 sluice valves or less of the different sizes. The contractor shall take this into account while quoting the rates for individual items. No separate payment shall be made for this work. In addition the Contractor shall submit a list of recommended spares for 5 years of operation and maintenance of all mechanical, electrical and instrumentation works covered under this

contract. Spares supplied shall be new, unused and interchangeable with the corresponding components they are intended to replace.

Flanges

Valves of sizes from 80 mm to 300 mm shall have flat flanges as per BIS:1538 Part IV Table I. Valves of sizes from 350 mm and larger shall have raised flanges as per BIS: 4504, Table 10/11 for 10 bar valves. The flange to flange distances shall be as per BIS:780 for 80 mm - 300 mm valves and BIS : 2906 for 350 mm and larger valves.

Jointing Materials

Each valve shall be supplied under this Contract, with all-requisite joint rings, nuts, bolts and washers for making the joints on all the valves to be installed under this Contract. Jointing material between the connecting flanges shall conform to the requirements of BIS 638- 1965. Unless otherwise specified bolting used for jointing exposed connections shall be carbon steel, conforming to BIS 210 Grade 20 Grade B, with galvanized finish. Bolting for buried joints and joints that could come into contact with raw sewage shall be Stainless Steel, as per Clause 2.02 A3. Boltholes shall be off-centre and in correct adjustment longitudinally.

Special Requirements - 450 mm and Larger Valves

Sluice valves in the size range 450 mm to 1200 mm shall have, in addition to the above requirements, the following features.

The valves shall have machined gun metal gate slides. Hard bronze shoes shall be provided on the gate and machined gunmetal channels in the body. The bronze shoes will be machined accurately to give a close working clearance with the channels. They shall provide corrosion resistant bearing surfaces and minimize sliding friction and vibration while maintaining accurate alignment. The use of cast iron channels with brass lining will be permitted if the lining is at least 6mm thick. The use of other materials for holding the channels in position will not be permitted.

The valves shall be provided with spur gearing consisting of machined mild steel pinions and cast iron wheels for valves installed underground. The pinion shafts shall run in gun metal bushes in a cast iron bearing bracket with provision for lubricating by a grease gun.

Gear wheel ratios will be such that a force of 270 Newton's applied on each end of a bar in combination with a Tee Key or extension spindle at the following distances from the key centre will permit smooth operation.

Valve size range (mm)	Distance of application of force (mm)
450 - 900	600
1200	750

Valves installed above ground shall be provided with worm gearing. These shall be machined cut, with bronze wheel and steel worm enclosed in a cast iron gear case which shall be mounted on a fitting connected to the valve cover flange and shall be complete with indicator column.

The worm shafts shall be equipped with ball thrust bearing and gunmetal bushes. The gearbox shall be oil filled and sealed. The worm shaft bearing shall be provided with grease

gun nipples. The gear ratios shall be so selected that the maximum force required to develop the requisite operating torque shall not exceed 180 Newton's.

All valves of size 450 mm or more shall have valve gate indicator columns with 10 mm graduations and indicating the fully open and closed positions. The indicator assembly should be sufficiently watertight to prevent entry of rainwater into the worm gear box in outdoor valves.

Factory Tests

All the valves shall be tested at the factory for smooth, trouble free operation and operating torque requirements by operating between fully open and fully closed position three times.

The hydrostatic tests shall consists of -

Application of a pressure equal to 1 and a half times the maximum working pressure specified in this section with both ends closed and valve fully open, for ten minutes. No leakage of water should occur through the metal, flanged joints or valve packing gland, nor should any permanent deformation of any part occur.

The pressure shall then be reduced to the working pressure and the wedge gate lowered, thus closing the valve. The stipulated pressures shall then be maintained for 5 minutes on each side in turn during which no leakage should occur on the downstream side of the valve seating.

Electric actuators

The sluice valve shall be operated by an electro-mechanical actuator, comprising of motorized gear train and screw assembly, which drives the valve stem. The actuator shall be supplied with the following accessories.

AC electric motor,

Reduction gear unit,

Torque switch mechanism complete with set of torque switches,

Limit switch mechanism complete with set of limit switches,

Hand wheel for manual operation,

Hand-auto changeover lever with suitable locking arrangement,

Local control switch / push buttons, and

415 V / 240 V AC control transformer

The actuator shall be suitable for operation in the climate conditions and power supply conditions given in the specification. The actuator shall be capable of producing not less than 1½ time the maximum required torque and shall be suitable for at least 15 minutes continuous operation.

AC Electric Motor

Each motor shall be fully tropicalised and suitable for operation in the prevailing climate conditions. They shall also be suitable for operating satisfactorily under variations of electric supply specified.

Motors

The electric motors shall be of 3 phase, squirrel cage type as per IS 325 with insulation to IS 1271 class "B". The winding shall be impregnated to render them non-hygroscopic and oil resistant. All internal metal parts shall be painted. The motor shall be rated for 30 min.

Motor Protection

The motor shall be protected by bimetallic over load relay. The relay shall be manually re-set type.

Motor Controls

The reversing contactor starter and local controls shall be integral with the valve actuator. The starters shall comprise mechanically and electrical interlocked reversing contactor of appropriate rating fed from a 220 V control transformer. The common connection of the contactor coils at the transformer shall be grounded. HRC type primary and secondary fuses shall be provided.

Local control shall comprise push buttons for open close and stop operations and a local / remote selector switch lockable in the three positions as below:

Local control only,

Remote control plus local stop only,

Stop locked off - No electrical operation

Vendor should also make a provision for transmitting the mode selected to control panel and control panel will have corresponding indication lamps.

Wiring and Terminals

Internal wiring shall be of grade PVC insulated stranded cable of 650 V and of minimum 1.5 sq.mm copper for control circuits and of minimum 4 sq.mm for the power circuit. Each wire shall be number identified at each end. The terminals shall be of stud type and they shall also be identified by numbers. Cable entries shall be suitable for PVC SWAPVC cables.

Enclosure

The actuator enclosure shall be IP 67.

Reduction Gear Unit

Reduction gear unit shall be of the totally enclosed oil bath lubricated type. The gearbox shall be provided with the first charge of oil lubricants and appropriate filling and drain connections. Gearing shall be adequate to open and close the valves under full indicated maximum operating pressure differential at a speed sufficient to cover the full extent of travel.

The valve operating equipment shall have a hammer-blow device to loosen stuck valve or retrieve jammed valve position.

The gearbox shall have suitable stops to prevent movement of shaft beyond fully open / close position. The gearbox shall also be designed for 15% more torque than maximum valve torque.

Torque Switch Mechanism

The torque switch mechanism shall function as follows to stop the motor on closing or opening of the valve, upon actuation by the torque when the valve disc is restricted in its attempt to open or close.

The torque switch in the closing direction shall interrupt the control circuit if mechanical overload occurs during the closing cycle or when the valve is fully closed. The torque switch in the opening direction shall interrupt the control circuit if mechanical overload occurs during opening cycle or when the valve is fully open.

The mechanism shall facilitate adjustment of the torque at which the switches are required to operate.

Limit Switch Mechanism

Non-adjustable limit switches shall stop the motor and give indication when the wedge has attained the fully open or closed position.

The adjustable limit switches shall function to actuate relays / switches, provided for system interlock, at the desired valve position in both the opening and closing directions.

Hand wheel

A hand wheel shall be provided for emergency operation. The hand wheel drive shall be mechanically independent of the motor drive and any gearing should be such as to permit emergency manual operation in a reasonable time.

Check Valves

Cast Iron Check Valves

60 mm to 350 mm diameter valves shall be swing check- valves of the lever and spring type, flanged, and shall have cast iron body and renewable bronze seat, bronze hinge, stainless steel hinge shaft. The valve shall conform to IS 5312 and, where any of the requirements specified are not covered therein, to U.S. Federal Specification WW-V-51 D, Type IV, Class A.

Cast Iron shall conform to ASTM A-126-66 and flanges to ANSI B 16.1. The valves shall be designed for low head loss, shall be adjustable for non-slamming closure and shall be seat-tight. An arrow showing direction of flow shall be prominently cast on body of valve. The water working pressure shall be 10 kg/cm square except that the valve shall have pressure rating same as the piping where the pipe class is higher. Valves shall be from approved manufacturer only.

Pump Check Valves larger than 400 mm Diameter

All check valves larger than 400-mm diameter installed on the pump discharge shall be flanged ductile iron body, cover disc, arm and levers. The seat shall be of renewable bronze ASTM B 148. The disc shall be hinged on a stainless steel shaft. The gate pins shall also be of stainless steel. The valves shall be designed for a working, pressure of 10kg/cm square. Valve operation shall be of the oil cushioned type such that the valve swing to 90 percent closed immediately upon stoppage of flow and cushioning cylinders shall control the final closure, to prevent mechanical slamming, within an adjustable timing of one to three seconds. The valves shall be from approved manufacturers only.

Single Faced Sluice Gates

General Specifications

The frames, doors, sealing faces and spindles shall be as specified in the appropriate clauses herein.

Each gate shall be provided with a suitable hand wheel of adequate diameter for the duty required and gearing shall be supplied where necessary to ensure that the required operating force applied by hand to the rim of the wheel does not exceed 25 kg.

Hand wheels shall have cast on them the direction of closing which shall be clockwise and vandal and weatherproof clear poly-carbonate tube covers shall be securely fitted to protect the threads of rising spindles. Each tube shall be clearly and permanently engraved to indicate the position of the Penstock to which it is fitted.

Spindles shall have machine cut robust trapezoidal or square form threads. They shall be of stainless steel or manganese steel, with the exception of non-threaded sections of extended spindle installations, which may be of mild steel. Extension spindle couplings shall be of the muff type and they shall be drilled and provided with a nut and bolt for securing the spindle to the Penstock spindle head, which shall likewise be drilled to receive the bolt.

Where extended spindles require to be operated at open flooring level, spindle guides or guide brackets shall be provided close to flooring level.

All Hand wheels, headstocks, floor brackets and guide brackets shall be of cast iron. Thrust tubes shall be galvanized mild steel or cast iron.

Fixing nuts and bolts supplied by the manufacturer shall be as specified in the appropriate clauses herein.

All gates shall be of the rising spindle type and provided with headstocks. Unless otherwise stated thrust tubes shall be provided between Penstock frame and headstock in order to absorb thrust in both directions of operation for gates of 300 mm (square or circular) and above. Thrust tubes shall incorporate all necessary fixing brackets and spindle guide plates.

All materials used in the manufacture of gates shall conform to the following minimum standards:

S.No.	Sluice Gate Component	Materials	Specification	Grades
1	Gate Frame, Shutter	Mild steel Stainless Steel Aluminium alloy	IS:2062-1992 ASTM A276	Grade A AISI:304, 316, 410
2	Resilient rubber seal	Natural Rubber EPDM Rubber Neoprene Rubber		
3	Rubber seal retainer bar	Mild Steel Stainless Steel	IS : 2062-1992 ASTM A276	Grade A AISI : 410
4	Coupling	Cast Iron Mild Steel Stainless Steel	IS : 210-1993 IS : 2062-1992 ASTM A276	FG 200 Grade A AISI : 410

S.No.	Sluice Gate Component	Materials	Specification	Grades
5	Operating Nut / Stem Nut	Leaded Tin Bronze	IS : 218-1981	LTB 1, LTB 2
6	Head stock, Stem guide bracket Stop nut	Cast Iron	IS : 210-1993	FG : 200
7	Fasteners & Studs	Mild Steel Stainless Steel	IS : 2062-1992 ASTM A276	Grade A AISI:410
8	Anchor Bolts	Mild Steel Stainless Steel	IS:2062-1992 ASTM A276	Grade A AISI:410
9	Yoke	Mild Steel	IS : 2062-1992	Grade A

Water Supply and Sanitary Works

Applicable Codes

The following standards and codes are made a part of this document. All standards, codes of practice referred to herein shall be the latest editions including all official amendments and revisions.

- IS : 210 : Specification for grey iron castings
- IS : 269 : Specification for ordinary and low heat Portland cement
- IS : 383 : Specification for coarse and fine aggregates from natural sources for concrete
- IS : 432 : Specification for mild steel and medium tensile steel bars and hard drawn steel wire for concrete reinforcement
- IS : 456 : Code of Practice for plain and reinforced concrete
- IS : 458 : Concrete Pipes (with and without reinforcement)
- IS : 516 : Methods of tests for strength of concrete
- IS : 554 : Dimensions for pipe threads where pressure tight joints are required on the threads
- IS : 651 : Salt glazed stoneware pipes and fittings
- IS : 774 : Flushing Cisterns for water closets and urinals (valve less siphonic type)
- IS : 775 : Cast iron brackets and supports for wash basins and sinks
- IS : 781 : Sand-cast brass screw-down bib taps and stop taps for water services
- IS : 783 : Code of practice for laying of concrete pipes
- IS : 1068 : Electroplated coatings of nickel and chromium of iron and steel
- IS : 1077 : Specification for common burnt clay building bricks
- IS : 1172 : Code of practice for basic requirements for water supply, drainage and sanitation
- IS : 1786 : Specification for high strength deformed steel bars and wires for concrete reinforcement
- IS : 1239 : Mild steel tubes (Part I) and mild steel tubulars and other wrought steel pipe fittings (Part II)
- IS : 1536 : Centrifugally cast (spun) iron pressure pipes for water, gas and sewage

- IS : 1626 : Asbestos cement building pipes, gutters and fittings (spigot and socket types)
- IS : 1703 : Copper Alloy float valves (horizontal plunger type) for water supply purposes
- IS : 1726 : Cast iron manhole covers and frames
- IS : 1729 : Sand cast iron spigot and socket soil, waste and ventilating pipes, fittings and accessories
- IS : 1742 : Code of practice for buildings drainage
- IS : 2065 : Code of practice for water supply in Buildings
- IS : 2116 : Specification for sand for masonry mortars
- IS : 2212 : Code of practice for brickwork
- IS : 2250 : Code of practice for preparation and use of masonry mortars
- IS : 2326 : Automatic flushing cisterns for urinals
- IS : 2470 : Code of practice for design and construction of septic tanks (Parts I & II)
- IS : 2556 : Vitreous sanitary appliances (Part I to Part XV)
- IS : 2963 : Specification for copper alloy waste fittings for wash basins and sinks
- IS : 3306 : Specification for chemically resistant glazed stoneware pipes and fittings
- IS : 3025 : Method for sampling and test (Physical and chemical) for water and waste water (Parts 1 to 44)
- IS : 3311 : Waste plug and its accessories for sinks and wash basins
- IS : 5455 : Specification for cast iron steps for manholes
- IS : 4127 : Code of Practice for laying of glazed stoneware pipes
- IS : 3495 : Methods of tests of burnt clay building bricks
- IS : 4111 : Code of practice for ancillary structures in sewerage system manholes
- IS : 5382 : Specification for rubber sealing rings for gas mains, water mains and sewers
- IS : 5329 : Code of practice for sanitary pipe work above ground for buildings
- IS : 5434 : Non-ferrous alloy bottle traps for marine use

Sanitary Installation

The work shall be carried out complying in all respects with any specific requirements of the local body in whose jurisdiction the work is situated, and as approved by the Engineer-in-charge.

Any damage caused to the building, or to installations therein, either due to negligence on the part of the Contractor, or due to actual requirements of the work, shall be made good and the building or the installation shall be restored to its original condition by the Contractor.

Licensed plumbers shall carry out all sanitary and plumbing work.

All sanitary appliance including sanitary fittings, fixtures, toilet requisites shall be of size, and design as approved by the Engineer-in-charge.

All white glazed porcelain fixtures, such as wash basin, sink drain board, water closet pan, and urinal, P' trap etc. shall have hard durable white glazed finish they shall be free from cracks and other glazing defects. No chipped porcelain fixtures shall be used.

Joints between iron and earthenware pipes shall be made perfectly air and watertight by caulking with neat cement mortar.

Indian Type Water Closet

Water closets shall be white porcelain Orissa type Indian soil pans, 690mm long conforming to IS: 2556 of approved make and pattern. Flushing cistern of 15b litres capacity with accessories such as chain, handle, stop tap, brass unions, jamb nuts, overflow pipe and bends, etc. shall be provided.

Urinals

Urinals shall be white glazed flat back type of approved make and of size 430 mm x 260 mm x 350 mm conforming to IS 2556. High level automatic CI flushing cistern of 10 litre capacity as per IS 2326 with necessary CI brackets, GI pipes for water connection from cistern to urinals, stop tap, waste pipe upto CI waste shaft etc. shall be provided.

Wash Basin

Wash basin shall be of white glazed earthenware conforming to IS 2556 of approved make and of size 560mm x 410mm. The wash basins shall be provided with water supply GI pipe, chromium plated tap, stopcock, CP bottle trap, GI waste water pipe and all necessary accessories and fittings.

Sinks

Sinks shall be of white glazed earthenware conforming to IS 2556 of approved make and of size 450mm x 300mm x 150mm. The sink shall be provided with CP tap, water supply GI pipe, non-ferrous waste fitting, waste plug and necessary accessories and fittings.

Soak Pit

Soak pit shall be constructed at the location specified by the Engineer-in-charge. Earthwork excavation shall be carried out to the exact dimensions. Brick masonry lining with open joints shall be constructed in the pit upto 150 mm below the outlet pipeline. Brick masonry in cement mortar 1:6 shall be constructed above this level up to ground. Well burnt brick, aggregates of nominal size 40 mm to 80 mm and coarse sand shall be filled within the chamber. Construction of pit lining and filling of the brick ballast shall progress simultaneously.

Manholes/Inspection Chambers

Location

Manholes / Inspection chambers shall be constructed at places approved by the Engineer-in-charge.

Excavation

Excavation, shoring, dewatering etc. for the pits of manholes / Inspection chambers, laying of pipes and fittings/specials shall be done in accordance with Engineer-in-charge requirements described elsewhere in the document.

Bed Concrete

The bed concrete for manholes/Inspection Chambers shall be done in accordance with Engineer-in-charge's requirements described elsewhere in the document.

Bricks

Bricks used for construction of manholes / Inspection chambers shall conform to the relevant Indian Standards. They shall be sound, hard, homogeneous in texture, well burnt in kiln without being vitrified, table moulded, deep red, cherry or copper coloured, of regular shape and size and shall have sharp and square and parallel faces. The bricks shall be free from pores, chips, flaws or humps of any kind. Bricks containing unground particles and/or which absorb water more than 1/6th of their weight when soaked in water for twenty-four hours shall be rejected. Overburnt or underburnt bricks shall be liable to rejection. The bricks shall give a clear ringing sound when struck and shall have a minimum crushing strength of 50 kg/sq.cm, unless otherwise noted in drawings. The class and quality requirements of bricks shall be as laid down in IS: 1077.

The size of the brick shall be 23.0 x 11.5 x 7.5 cm unless otherwise specified; but tolerance upto + 3 mm in each direction shall be permitted. Only full size brick shall be used for masonry work. Brickbats shall be used only with the permission of Engineer-in-charge to make up required wall length or for bonding. Sample bricks shall be submitted to the Engineer-in-charge for approval and bricks supplied shall conform to approved samples. If required by the Engineer-in-charge, brick samples shall be tested as per IS:3495 by Contractor. Bricks rejected by the Engineer-in-charge shall be removed from the site within 24 hours.

Cement Mortar

Mortar for brick masonry shall be prepared as per IS:2250, Manholes / Inspection chambers shall be constructed in brick masonry with cement mortar (1:3) unless otherwise specified. Gauge boxes for sand shall be of such dimensions that one bag containing 50 kg of cement forms one unit. The sand shall be free from clay, shale, loam, alkali and organic matter and shall be of sound, hard, clean and durable particles. Sand shall be as approved by the Engineer-in-charge. If required by the Engineer-in-charge and shall be thoroughly washed till it is free of any contamination.

For preparing cement mortar, the ingredients shall first be mixed thoroughly in dry condition. Water shall then be added and mixing continued to give a uniform mix of required consistency. Cement mortar shall be used within 25 minutes of mixing. Mortar left unused in the specified period shall be rejected.

The Contractor shall arrange for tests on mortar samples if so required by Engineer-in-charge. Retempering of mortar shall not be permitted.

Brick Masonry

All bricks shall be thoroughly soaked in clean water for at least one hour immediately before being laid. Brick work 230 mm thick and over shall be laid in English Bond unless otherwise specified. 115 mm thick brick work shall be laid with stretchers. For laying bricks, a layer of mortar shall be spread over the full width of suitable length of the lower course. Each brick shall be pressed into the mortar and shoved into final position so as to embed the brick fully in mortar. Bricks shall be laid with frogs uppermost.

All brickwork shall be plumb and square unless otherwise shown on drawing and true to dimensions shown. Vertical joints in alternate courses shall come directly one over the other and be in line. Horizontal courses shall be leveled. The thickness of brick course shall be kept uniform. For walls of thickness greater than 230 mm both faces shall be kept in vertical planes unless otherwise specified. All interconnected brickwork shall be carried out at nearly one level (so that there is uniform distribution of pressure on the supporting structure) and no portion of the work shall be left more than one course lower than the adjacent work. Where this is not possible, the work shall be raked back according to bond (and not saw-toothed) at an angle not exceeding 45 degrees. But in no case the level difference between adjoining walls shall exceed 1.25 m. Workmanship shall conform to IS:2212.

Brick shall be so laid that all joints are well filled with mortar. The thickness of joints shall not be less than 6 mm and not more than 10 mm. The face joints shall be raked to a minimum depth of 12 mm by raking tools daily during the progress of work when the mortar is still green, so as to provide a proper key for the plastering to be done. When plastering is not required to be done, the joints shall be uniform in thickness and be struck flush and finished at the time of laying. The face of brickwork shall be cleaned of all dirt before another course is laid on top. If mortar in the lower course has begun to set, the joints shall be raked out to a depth of 12 mm before another course is laid.

Cement Plaster

All joints in masonry shall be raked to a depth of 12 mm with hooked tool made for the purpose when the mortar is still green and in any case within 48 hours of its laying. The surface to be rendered shall be washed with fresh clean water free from all dirt, loose material, grease etc. and thoroughly wetted for 6 hours before plastering work is commenced. Concrete surfaces to be rendered will however be kept dry. The wall should not be too wet but only damp at the time of plastering. The damping shall be uniform to get uniform bond between the plaster and the wall.

Cement shall be mixed thoroughly in dry condition and then just enough water added to obtain a workable consistency. The quality of water, sand and cement shall be as per relevant IS. The mortar thus mixed shall be used immediately and in no case shall the mortar be allowed to remain for more than 25 minutes after mixing with water.

Curing of plaster shall be started as soon as the applied plaster has hardened enough so as not to be damaged. Curing shall be done by continuously applying water in a fine spray and shall be carried out for at least 7 days.

Plastering shall be done on both faces of brick masonry in cement mortar (1:2) and 20 mm thick unless otherwise specified.

Plastering work shall be carried out in two layers, the first layer being 14 mm thick and the second layer being 6 mm thick. The first layer shall be dashed against the prepared surface with a trowel to obtain an even surface. The second layer shall then be applied and finished leaving an even and uniform surface, trowel finished unless otherwise approved by the Engineer-in-charge.

Cement Concrete Channel

The channel for the manhole shall be constructed in cement concrete of M15 grade. Both sides of the channel shall be taken up to the level of the crown of the outgoing sewer. They shall be benched up in concrete and rendered in cement mortar (1:1) of 20 mm thickness and formed to a slope of 1 in 12 towards the channel.

Pipe Entering or Leaving Manhole / Inspection Chamber

Whenever a pipe enters or leaves a manhole / inspection chamber, bricks on edge must be cut to a proper form and laid around the upper end of the pipe so as to form an arch. All around the pipes, there shall be a joint of cement mortar (1:2) 13 mm thick between it and the bricks.

Cast Iron Steps

Cast iron steps shall be as per IS:5455. The steps shall be of grey cast iron of grade 15 as per IS:210. The steps shall be clean, well cast and they shall be free from air and sand holes, cold shuts and wrappings. The portion of the step which projects from the wall of the manhole / inspection chamber shall have a raised chequered design to provide an adequate non-slip grip. CI steps shall weigh not less than 4.5 kg each and shall be of 150 mm x 375 mm overall dimensions. These steps shall be coated with a black bituminous composition. The coating shall be smooth and tenacious. It shall not flow when exposed to a temperature of 63 degrees C and shall not be brittle as a chip of at temperature of 0 degree C.

Where the depth of invert of manhole exceeds 800 mm, cast iron steps of approved pattern shall be fixed in the brick work at the interval of 300 mm vertically and staggered at 380 mm horizontally centre to centre. In case of pipe diameter greater than 600 mm, box type CI steps weighing 19 kg each shall be provided at 300 mm vertically in channel of manhole / inspection chamber.

Frame and Covers

Frame and covers for manholes shall be of required type and dimensions as per the relevant drawings prepared by the Contractor. Following information shall be clearly marked on each cover.

Year of manufacture,

Identification mark of the purchaser

SEWERS/SWD

Arrow showing direction of flow

Cast Iron Frame and Cover

The cast iron frame and cover shall be of grey cast iron as per IS: 1726. The general requirements for casting and coating of CI frame and cover shall be as specified for CI steps in Clause 15.15.10. The covers shall have a raised chequered design to provide an adequate non-slip grip. The rise of the chequer shall be not less than 4 mm. The locking device for the cover shall be provided as approved by the Engineer-in-charge. The CI covers for the load test shall be selected at one for every lot of fifty or part thereof for each type and size

manufactured and as approved by the Engineer-in-charge. The frame shall be fixed in cement concrete of M15 grade all round and finished with neat cement. The manhole frame shall have 560 mm diameter clear opening and shall weigh not less than 208 kg. including cover. In case of rectangular CI frame and cover of 900 mm x 600 mm clear opening, the total weight shall not be less than 275 kg. In case of scraper manhole the frame shall have clear opening of 1200 mm x 900 mm and shall weigh not less than 900 kg including cover. The manhole / inspection cover and frame shall be painted with three coats of anti-corrosive paint after fixing in position.

Fiber Reinforced Concrete Frame and Cover

Fiber reinforced concrete frame and cover shall be capable of withstanding load of 35 tones. The frame shall be fixed in cement concrete of M15 grade all around and finished with neat cement. The fiber-reinforced frame shall have clear opening of 560 mm diameter and weighing 103 kg. The cover shall have a minimum thickness of 100 mm and weighing 78 kg. The fibers shall constitute 1% of the weight of the concrete in the form of 50 mm to 100 mm long high tensile steel wires. For the cover, MS sheet lapping of 18 gauge shall be provided to avoid damage to the edges. Similarly for frame, MS angle/flat shall be provided along the edge. Both MS sheet and angle shall be painted with black bituminous paint. The cover should have suitable lifting arrangement. The fiber reinforced frame and cover shall be manufactured as approved.

Reinforced Cement Concrete Frame and Cover

Reinforced cement concrete frame and cover for manholes shall be of required dimensions and shape as shown on the drawing prepared by the Contractor and approved by the Engineer-in-charge. The frame and cover shall be cast in cement concrete of M20 grades. Minimum cover to the reinforcement shall be 40 mm. The edges of frame and covers shall be provided with mild steel angles to avoid damages to the corners. These angles shall be painted with black bituminous paint. The covers should have suitable lifting arrangement.

RCC Manhole

M20 grade of concrete used for construction of RCC manhole shall have min cement content of 390kg/cum of concrete. Min cover to the reinforcement shall be 50mm.

Vent Shafts

General

Vent shafts shall be erected at such places as approved by the Engineer-in-charge.

GI Pipe Vent Shaft

GI pipe vent shall be of 100 mm diameter of 'C' class as per IS: 1239 and 6 meter height from ground level with slotted cap. The vent shaft shall be embedded in concrete of M10 grade and anchored with a 6mm thick MS base plate of 200 mm x 200 mm. The vent shaft shall be painted with one coat of silver paint over one coat of red lead oxide paint. The vent shaft shall be connected to manhole by 150 mm diameter glazed stoneware pipe encased by M10 concrete of 150 mm thickness all around as approved by the Engineer-in-charge.

RCC Vent Shaft

Reinforced cement concrete vent shaft shall be of M20 grade concrete, 200 mm diameter at bottom and tapered to 100 mm diameter at top (both inside clear openings) and 6 m height

from ground level. The vent shaft shall be embedded in concrete of M10 grade and anchored by 2 nos. of 16 mm diameter and 600 mm long MS bars. The vent shaft shall be connected to manhole as specified in (b) above through a brick masonry flue chamber.

Septic Tank

The sewer line shall be connected to a septic tank of adequate capacity and design including necessary soak pit. All the works involved, such as excavation, refilling, accessories, fittings, vent pipe, cowl cap, etc. as specified & directed shall be carried out.

Miscellaneous

If any damage is caused to the other services such as water supply pipeline, sewer, cable, etc. during the construction of manholes and erection of vent shafts, the Contractor shall be held responsible for the same and shall replace the damaged services to the full satisfaction of the Engineer-in-charge. The interior of manholes shall be cleared of all debris after construction and before testing the same for water tightness by the Contractor.

Roadside Drains

Applicable Codes and Specifications

The following specifications, standards and codes are referred to in this part

All earthwork shall be according to Engineer-in-charge specified under Section n “*Earthwork*”.

Slab Culvert

Slab culverts shall be constructed at specified locations of the existing cross drainage works as directed by the Engineer-in-charge. The Concrete works specifications for construction of RC slab and the rubble masonry specifications for the supporting rubble walls shall be followed as per Employer’s Requirements described elsewhere:

Bitumen at Location of Contact

The bitumen to be used on the top of the bed concrete at the location of contact of RCC slab above in two coats shall be straight run bitumen of specified grade.

Graded Gravel Free Draining Backfill

On each side of the uncoarsed rubble walls supporting the slab culvert a free draining backfill of thickness 200 mm shall be provided. The material for this backfill shall be granular consisting of sound, tough, durable particles of crushed or uncrushed gravel, crushed stone or brickbats which will not become powdery under loads and in contact with water. The material shall be free from soft, thin, elongated or laminated pieces and vegetable or other deleterious substances. It shall be graded and shall meet the grading requirements given in hereunder.

Sieve Designation	Percent Passing by Weight
10 mm	100
4.75 mm	30-65
425 microns	5-30
150 microns	0-10

Weep Holes

Weep holes as shown on the drawings or as directed by the Engineer-in-charge shall be provided in the masonry to drain water from the backfilling. Weep holes shall be of asbestos cement pipes conforming to IS: 6908 in rubber walls with necessary M10 concrete cushioning 75 mm thick. They shall extend through the full width of the masonry at a spacing of 1.5 m c/c and with slope of about 1 vertical to 20 horizontal towards the drainage face.

Pipe Drains

Wherever required, pipe drains shall be provided for cross drainage purposes. The sequence of construction shall be as follows:

laying of sand/shingle bedding on the original ground

laying of PCC of M10 grade

laying of concrete pipes of NP2 NP3 class as per IS:458

Constructing embankment above in compacted murum, laying of the sub-base and Water bound Macadam as specified hereinabove.

The details of above works as directed by Engineer-in-charge shall be followed.

Materials for Pipe Drains

All materials used in the construction of pipe drains shall conform to Engineer-in-charge. RCC pipes class NP3 shall conform to IS: 458.

Each consignment of cement concrete pipes shall be inspected, tested if necessary, and approved by Engineer-in-charge at the place of manufacture or at site before their incorporation in the Works.

Excavation for pipes

The foundation bed for pipe drain shall be executed true to the lines and grades shown on the drawings or as directed by the Engineer-in-charge. The pipes shall be placed in shallow excavation of the natural ground in open trenches cut in the existing embankment, taken down to levels as shown in the drawings. Where trenching is involved, its width on either side of pipe shall not be less than 150 mm nor more than one-third the diameter of pipe. The sides of the trench shall be as nearly vertical as possible.

When during excavation, the material encountered is soft, spongy or other unstable soil, unless other special construction methods are called for as indicated on drawings, such unsuitable material shall be removed upto a depth of 600 mm or as directed by the Engineer-in-charge before placing any backfill material.

When bed rock or boulder strata are encountered, excavation shall be taken down at least 200 mm below bottom level of pipe as directed by Engineer-in-charge and space filled with approved sand and shingle. Trenches shall be kept free from water until the pipes are installed and the joints have been hardened.

Bedding for pipe

The bedding surface shall provide a firm foundation of uniform density throughout the length of the pipe drain and shall conform to the specified level and grade. The pipe shall be laid on the concrete bedding before the concrete has set.

Laying of pipes

No pipes shall be placed in position until the foundations have been approved by Engineer-in-charge. When pipes are to be laid adjacent to each other, they shall be separated by a distance at least equal to or greater than half the diameter of pipe subject to a minimum of 450 mm.

The laying of pipes on the prepared concrete foundation shall start from the outlet and proceed towards the inlet and be completed to the specified lines and grades. The pipes shall be fitted and matched so that when laid they form a drain with a smooth uniform invert. Any pipe found defective or damaged during laying shall be removed at the cost of the Contractor.

Jointing

All the joints shall be made with care so that their interior face is smooth and consistent with the interior surface of the pipes. The ends of the pipes should be so shaped as to form a self-centering joint with jointing space 13 mm wide. The jointing space shall be filled with cement mortar (1 cement to 2 sand) mixed sufficiently dry to remain in position when forced with a trowel or rammer. Care shall be taken to fill all voids and excess mortar shall be removed. After finishing the joints shall be kept covered and damp for at least four days.

Back filling

Trenches shall be backfilled with selected materials as per Employer's Requirements given in this part. Backfilling upto 0.3 metre above the top of pipe shall be carefully done and murum shall be thoroughly consolidated under the haunches of the pipe.

Concrete Encasement

Concrete encasement shall be provided at places wherever directed by the Engineer-in-charge.

SECTION - VI

DRAWINGS

LIST OF DRAWINGS

1. State Map
2. District Map
3. Block Map
4. Flow diagram
5. Index Plan
6. Site Plan of IPS-I
7. Pump House
8. Staff Quarter Type – I
9. Staff Quarter Type – III
10. Boundary Wall & Gate
11. RCC Reservoir
12. Break Pressure Tank
13. Sluice / Scour / Reflux / Air Valve Chamber
14. Wheel Valve Chamber
15. Protection Work

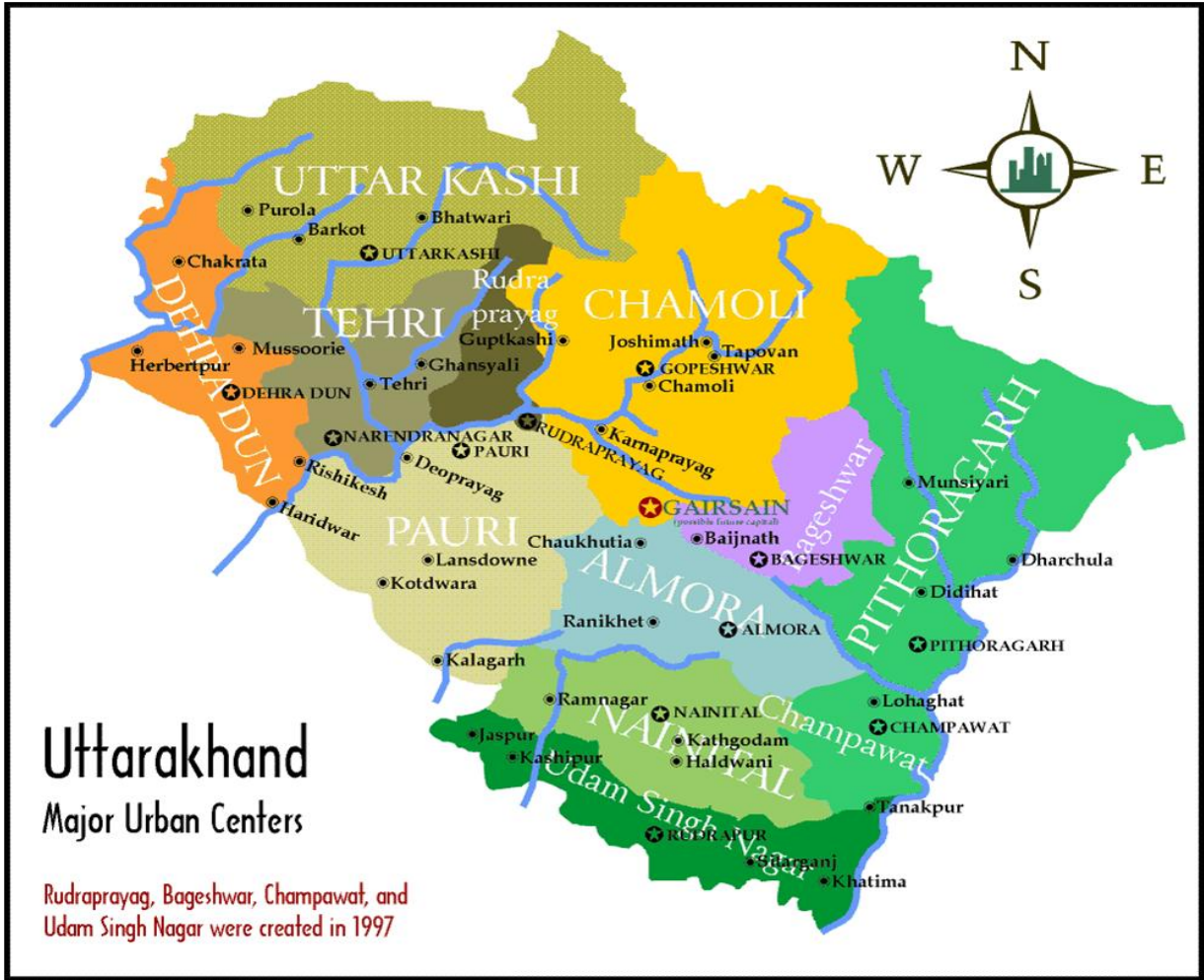

DISTRICT TEHRI-GARHWAL

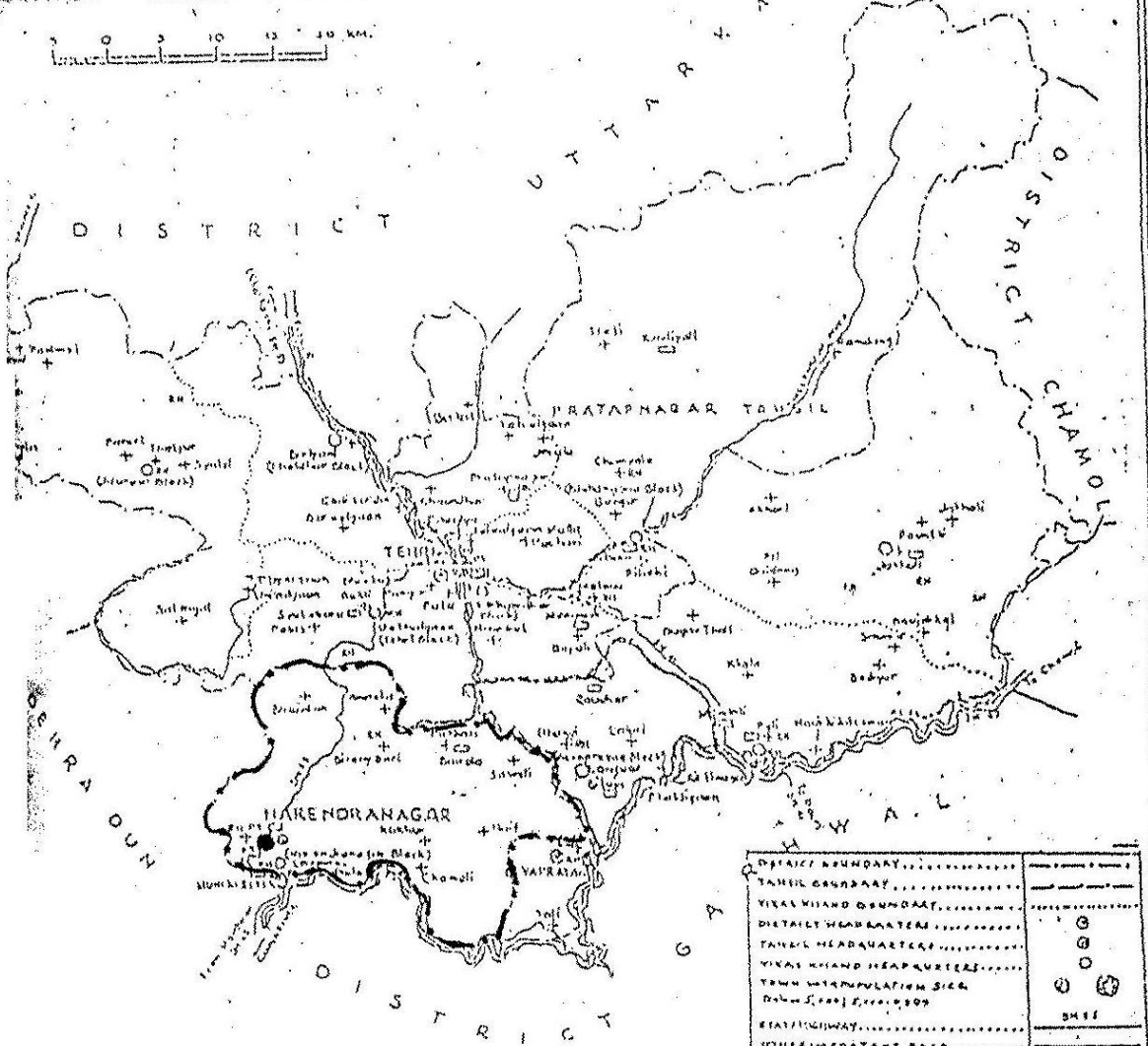
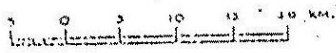

Name of the Tehsil	Area in Km ²	Population	No. of Villages	No. of Panchs
TEHRI	H.A.	109,105	473	1
PRATAPNAGAR	H.A.	114,537	476	1
DEHRANAGAR	H.A.	172,708	816	3
TOTAL	44370	396,350	2,015	5

DISTRICT BOUNDARY	-----
TALUK BOUNDARY	-----
VILLAGE BOUNDARY	-----
DISTRICT HEADQUARTERS	○
TALUK HEADQUARTERS	○
VILLAGE HEADQUARTERS	○
TOWN CENSUS POPULATION OVER 5000	○
STATION	SM
OTHER IMPORTANT MARKS	-----
RIVER AND STREAM	~~~~~
POLICE STATION	PS
POST TELEGRAPH OFFICE	PT
REVENUE TRAVELLERS	CH
HOSPITAL, DISPENSARY, M.C. CENTRE, DISTRICT OFFICE, S.P. OFFICE, ETC.	+

**CONSTRUCTION DIVISION UTTARANCHAL
PAYJAL NIGAM MUNI KI RETI (TEHRI)**

DISTT. MAP OF TEHRI (GARHWAL)

DRAWN BY

[Signature]

A.E.

E.E.

BLOCK MAP OF NARENDRA NAGAR

TEHRI-GARHWAL
YEAR - 2001

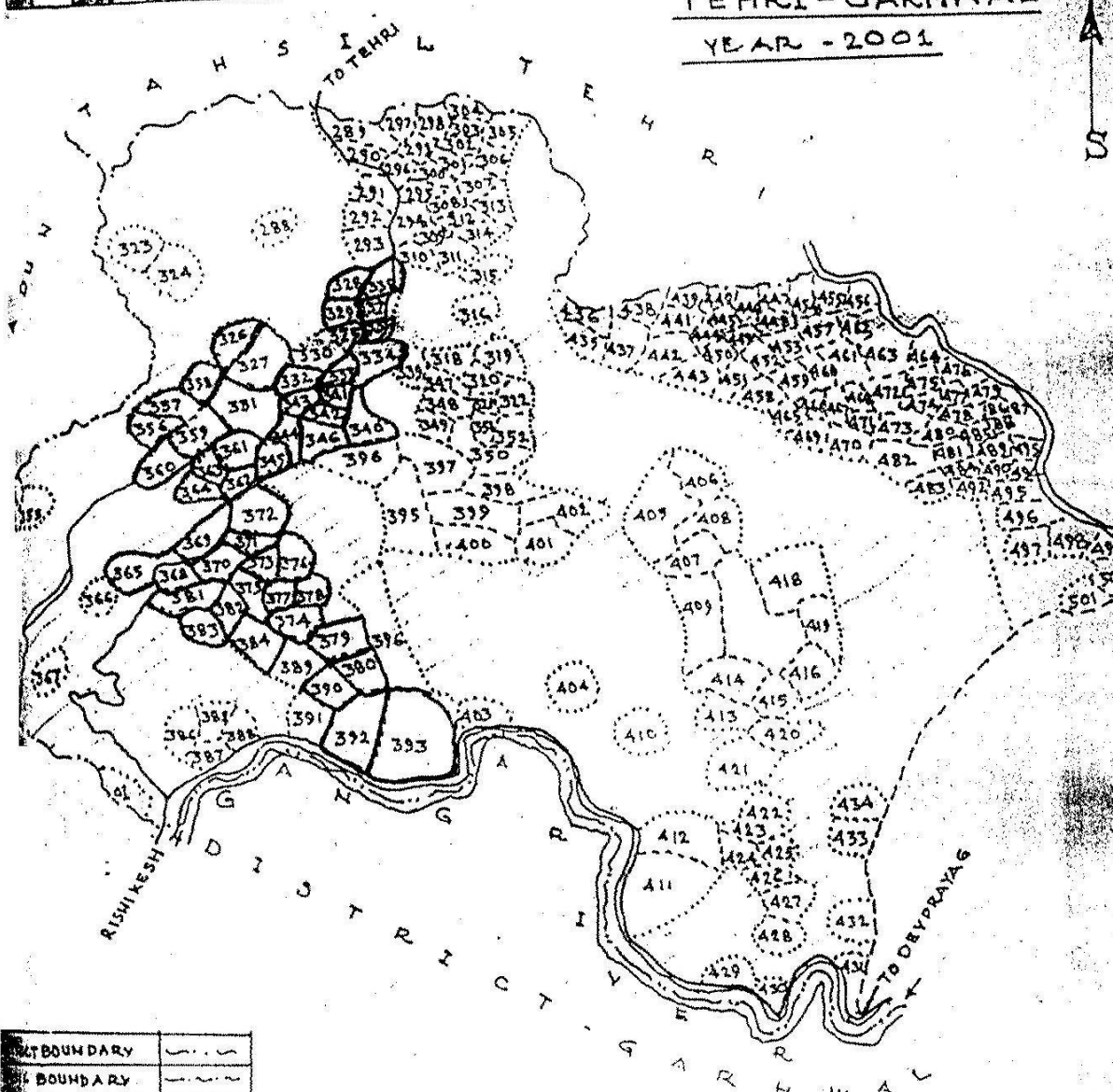

BLOCK BOUNDARY	— — — — —
VILLAGE BOUNDARY	— — — — —
ROAD	— — — — —
RAILWAY	— — — — —
WATER	— — — — —
POPULATION YEAR 2001	004 ... 00

J.E. A.E. E.E.
CONST. DIV. UTTARANCHAL DEVAL NIGA
MUNI KIRETI (T. GARHWAL)

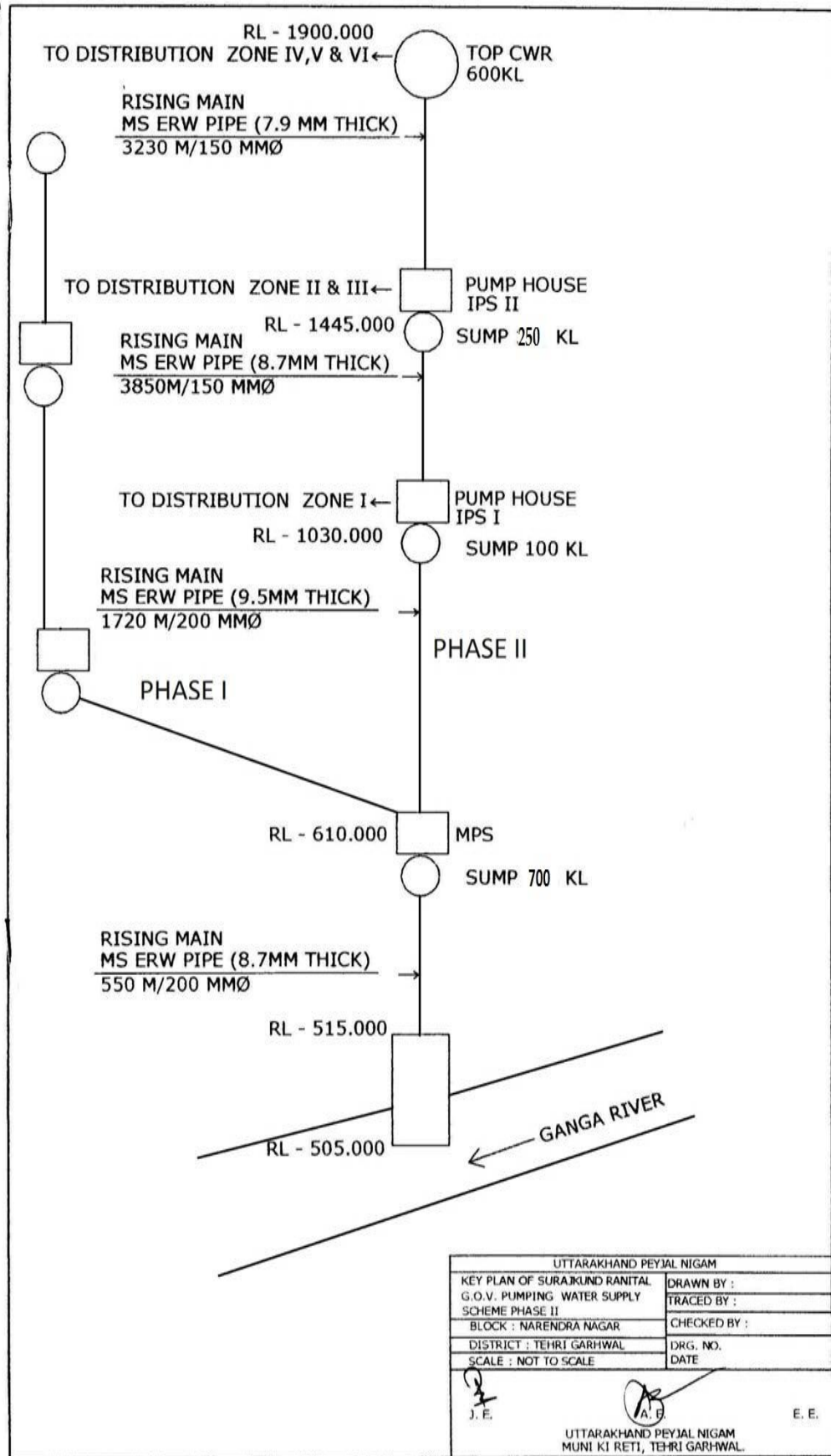

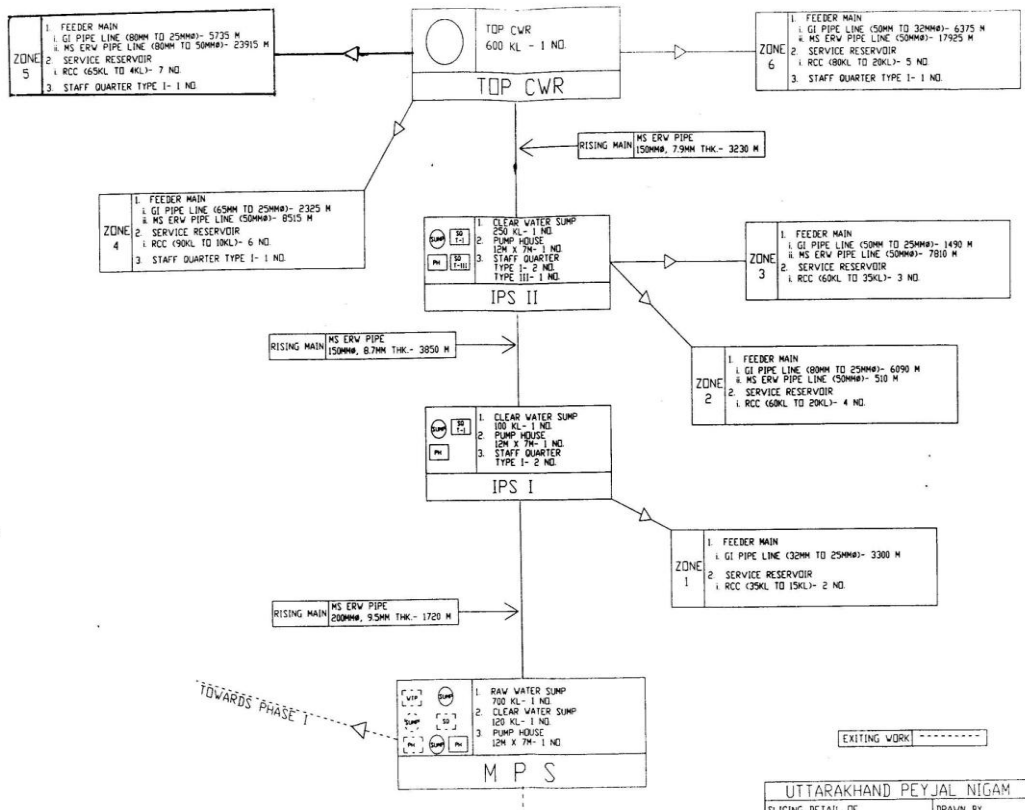

EXITING WORK -----

UTTARAKHAND PEYJAL NIGAM	
SLICING DETAIL OF SURAKUND RANITAL (PUMPING) WATER SUPPLY SCHEME PHASE II	DRAWN BY
BLDCK NARENDRA NAGAR	TRACED BY
DISTRICT TEHRRI GARHWAL	CHECKED BY
SCALE NOT TO SCALE	DRG NO DATE
J E	E E
CONSTRUCTION DIVISION UTTARAKHAND PEYJAL SANSIDHAN VIKAS EVAM NIRMAN NIGAM, MUNI KI ROTTI	

**SURAJKUND RANITAL G.O.V. WATER SUPPLY SCHEME PHASE II
SITE PLAN OF IPS-1**

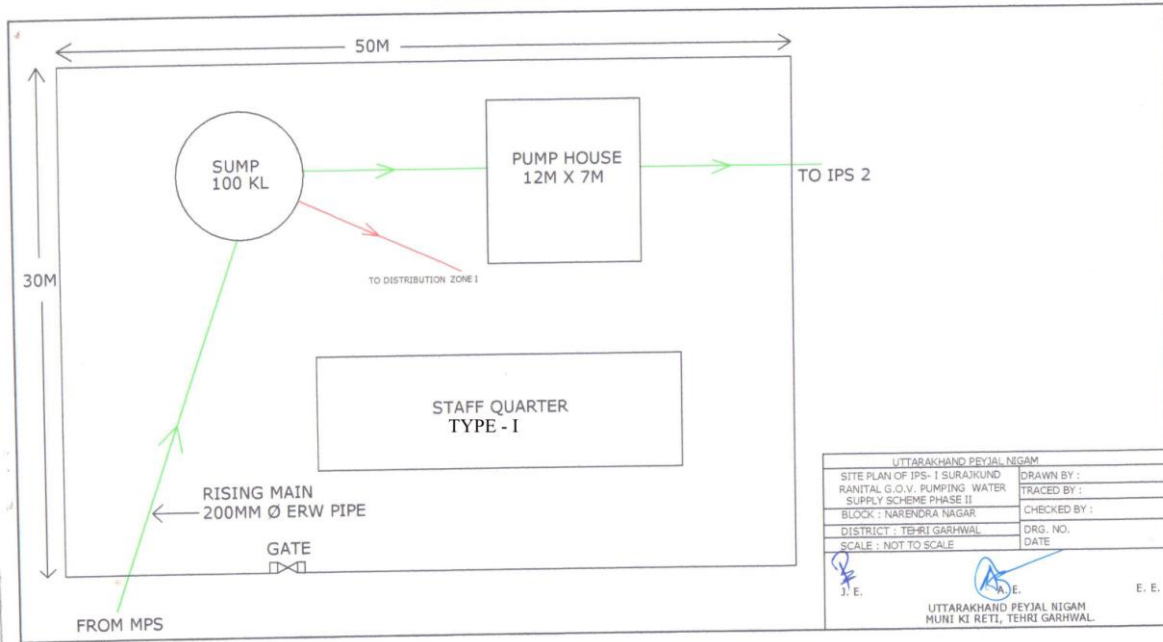

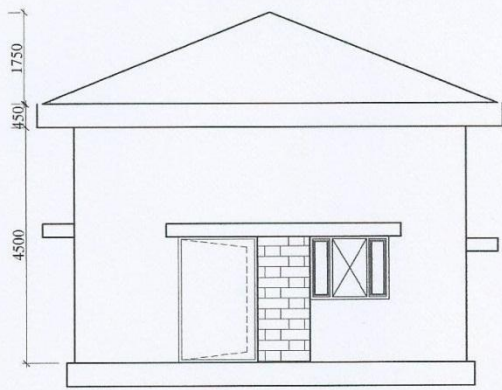

FRONT ELEVATION

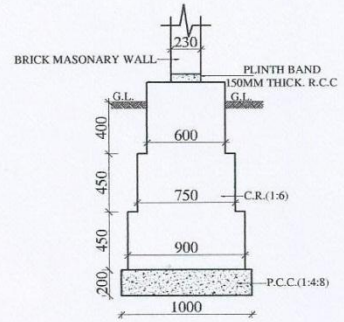

SECTION OF FOUNDATION

DETAIL OF CORNER

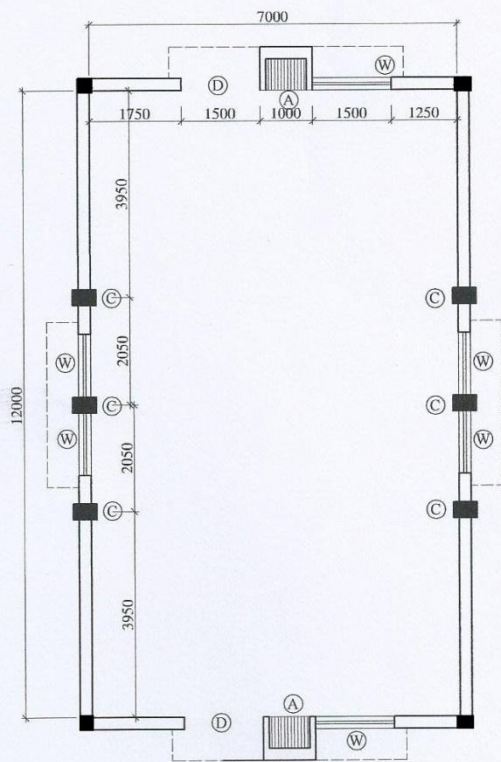

PLAN

SIDE ELEVATION

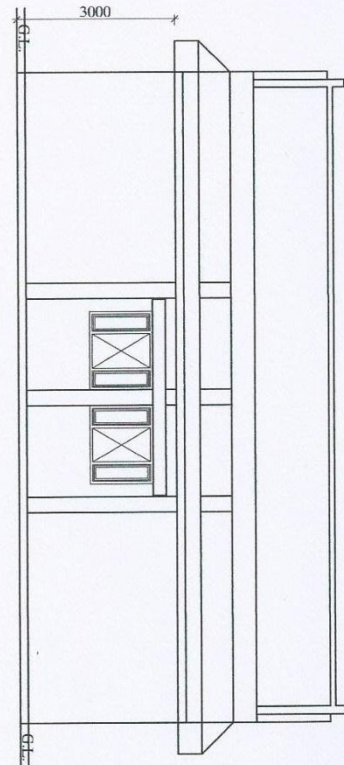

1.	D - DOOR	1500X2100
1.	W - WINDOW	1200X1200
1.	A - ALMIRA	1540X2100
1.	C - COLUMN	300X450

CONSTRUCTION DIVISION UTTRAKHAND PAY JAL NIGAM MUNI KI RETI (TEHR)		
PUMP HOUSE		
SURAJKUND RANITAL G.O.V. (PUMPING) W/S SCHEME PHASE II		
J.E.	A.E.	E.E.

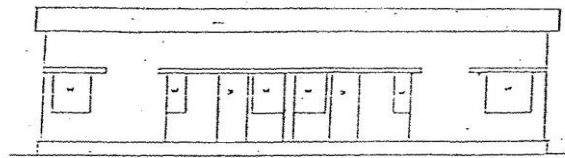

FRONT ELEVATION

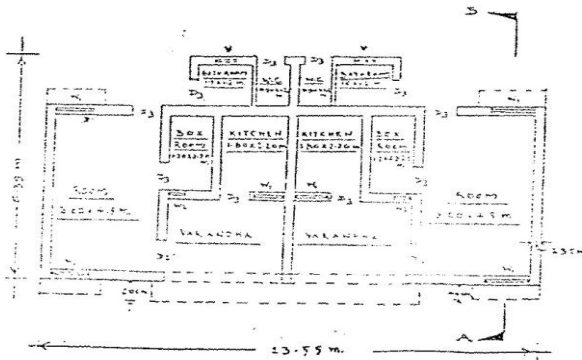

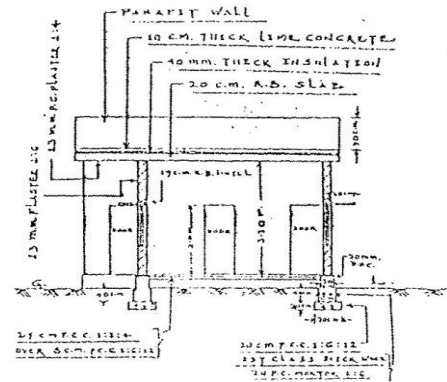

PLAN

V ₁	0.50	x	1.20	m.
V ₂	0.50	x	1.20	m.
V ₃	7.00	x	2.40	m.
V ₄	0.60	x	2.40	m.
V ₅	0.60	x	0.60	m.



SECTION ON A-B

CONSTRUCTION DIVISION UTTARANCHAL PAYJAL NIGAM MUNI KI RETI (TEHRI)		
SET OF SINGLE ROOM STAFF QUARTER		
SURAJKUND RANITAL G.O.V. (PUMPING) W/S SCHEME PHASE II		
DRAWN BY 	 A.E.	 E.E.

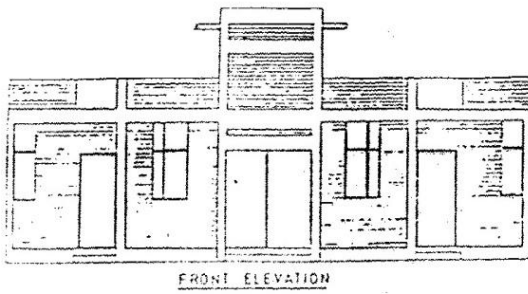

FRONT ELEVATION

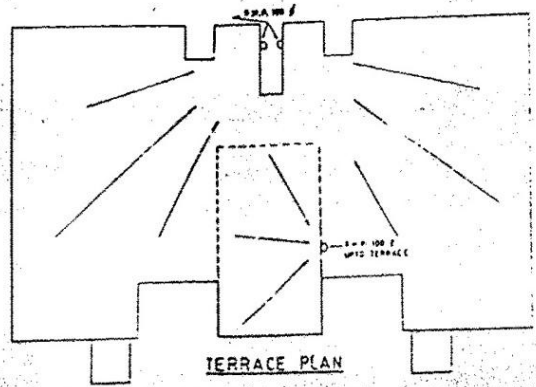

TERRACE PLAN

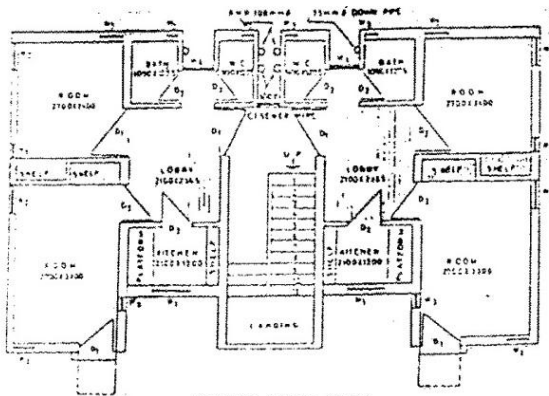

GROUND FLOOR PLAN

SCHEDULE OF DOORS & WINDOWS

S.NO	TYPE	WIDTH	HEIGHT	REMARKS
1.	D ₁	1000	2100	0200
2.	D ₂	710	2100	00
3.	W ₁	100	100	0000
4.	W ₂	600	1100	00
5.	W ₃	300	1100	00
6.	W ₄	150	1000	00

NOTES:

1. ALL DIMENSIONS ARE IN MM
2. FIGURED DIMENSIONS SHOULD BE FOLLOWED
3. THE ELEVATION OF THE BUILDING OR DEVELOPED THROUGH ARCHITECTS IN ACCORDANCE WITH THE SURROUNDINGS WHERE PROPOSED TO BE CONSTRUCTED

**CONSTRUCTION DIVISION UTTANCHAL
PAY JAL NIGAM MUNI KI RETI (TEHRI)**

SET OF DOUBLE ROOM STAFF QUARTER

SURAJKUND RANITAL G.O.V. (PUMPING) W/S SCHEME PHASE II

DRAWN BY 		
	A.E.	E.E.

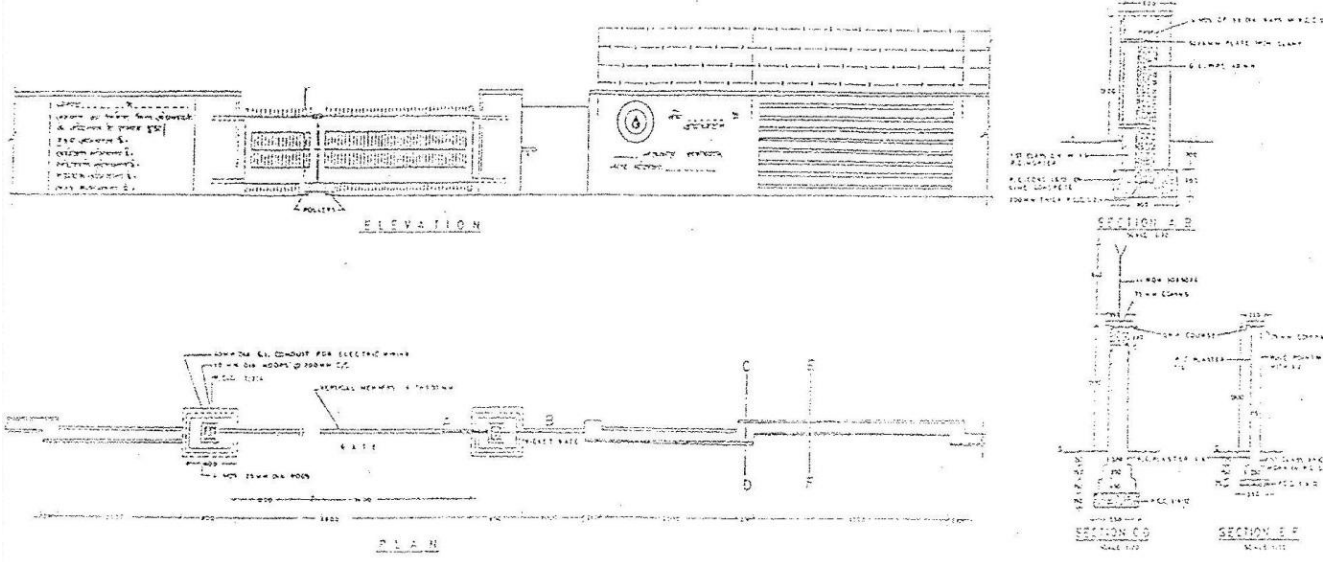

CONSTRUCTION DIVISION UTTRANCHAL PAY JAL NIGAM MUNI KI RETI (TEHRI)	
TYPE DESIGN FOR 3.6 M WIDE GATE & BOUNDARY WALL	
SURAJKUND RANITAL G.O.V. (PUMPING) W/S SCHEME PHASE II	
DRAWN BY <i>S.S.D.</i>	A.E.
	<i>E.E.</i>

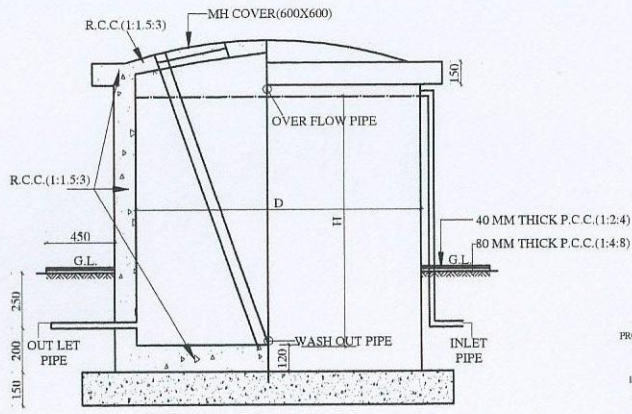

SECTIONAL ELEVATION ON A.B.C.

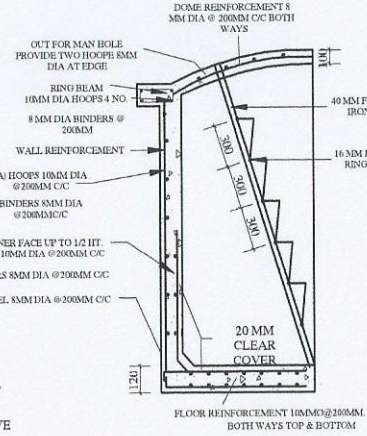

DETAILS OF REINFORCEMENT

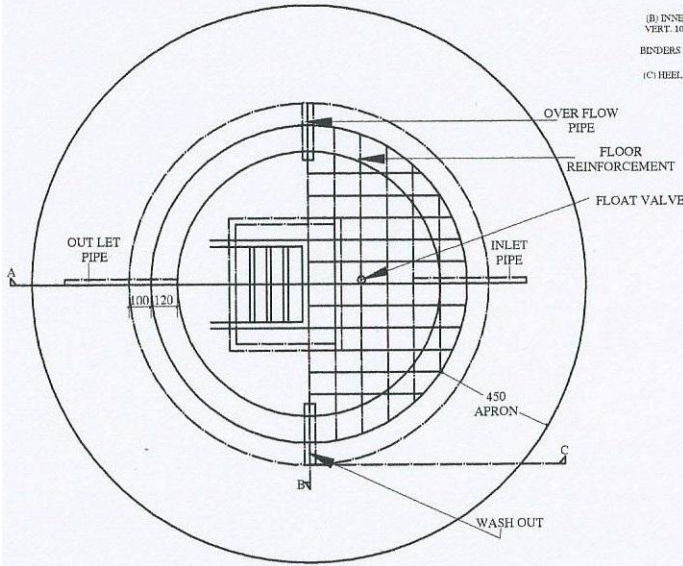

PLAN

S. NO.	CAPACITY IN LITERS	H IN MM	D(INNER DIA) IN MM
1.	3000	1650	1600
2.	4000	2150	1600
3.	5000	2650	1600
4.	7500	1800	2400
5.	10000	2350	2400
6.	12500	2950	2400
7.	15000	2050	3200
8.	17500	2400	3200
9.	20000	2700	3200
10.	22500	2950	3200
11.	25000	3250	3200

NOTE- ALL DIMENSIONS ARE IN MM.

CONSTRUCTION DIVISION UTTRAKHAND PARYAJAL NIGAM MUNI KI RETI (TEHRI)		
TYPE DESIGN FOR R.C.C. RESERVOIR		
SURAJKUND RANITAL G.O.V. (PUMPING) W/S SCHEME PHASE II		
J.E.	A.E.	E.E.

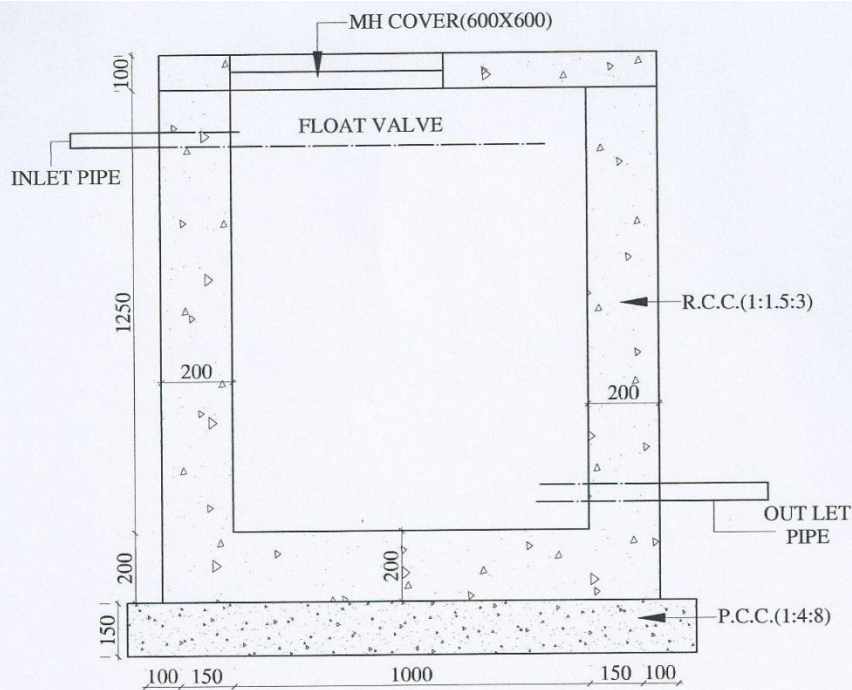

SECTION AT AB

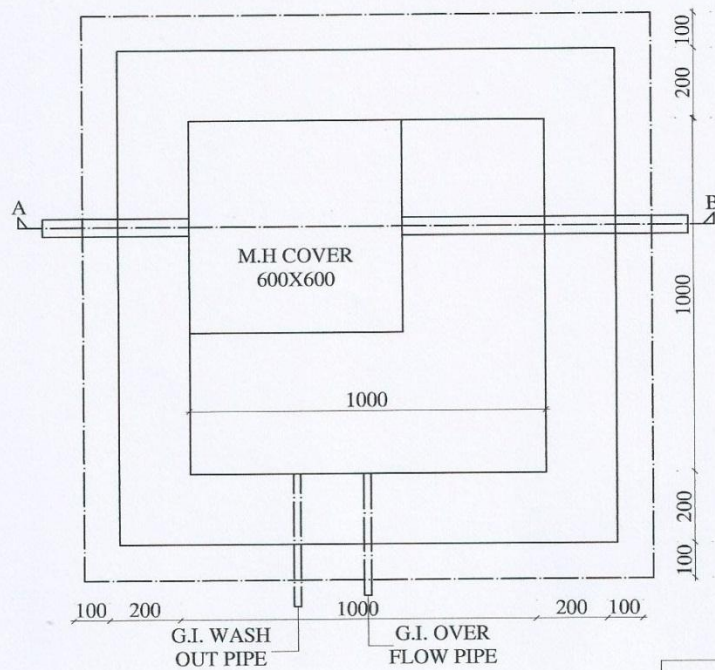

PLAN

NOTE- ALL DIMENSIONS ARE IN MM.
 DETAIL OF REINFORCEMENT- 100@100MM. C/C
 (BOTH WAYS & BOTH FACES)

CONSTRUCTION DIVISION UTTRAKHAND PARY JAL NIGAM MUNI KI RETI (TEHR)		
BREAK PRESSURE TANK		
SURAJKUND RANITAL G.O.V. (PUMPING) W/S SCHEME PHASE II		
J.E.	A.E.	E.E.

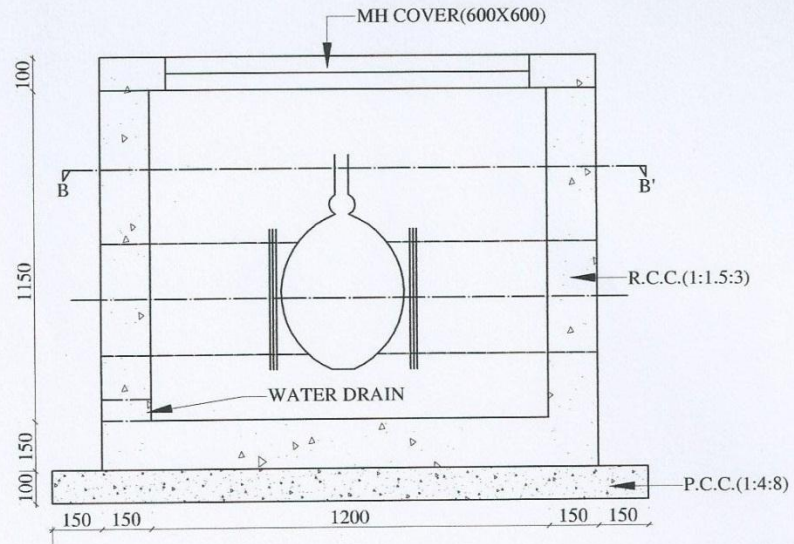

SECTION AT AA'

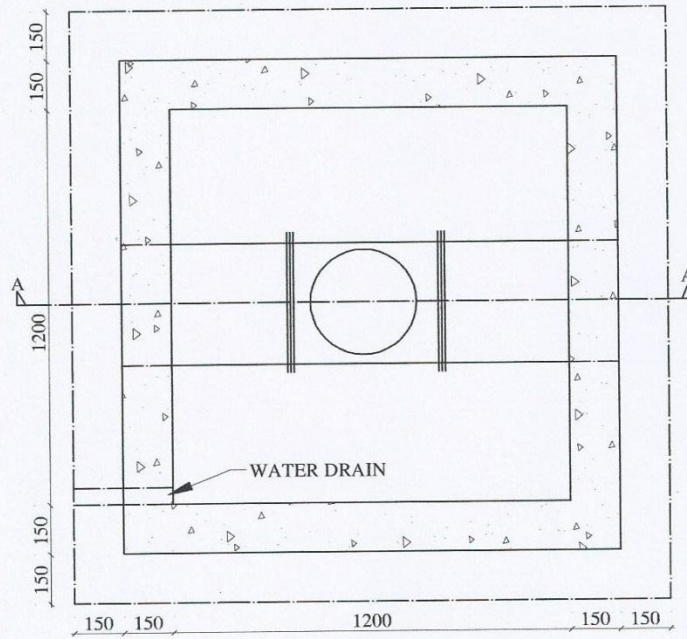

SECTION AT BB'

NOTE- ALL DIMENSIONS ARE IN MM.

DETAIL OF REINFORCEMENT- 80@100MM. C/C
(BOTH WAYS)

CONSTRUCTION DIVISION UTTRAKHAND PARY JAL NIGAM MUNI KI RETI (TEHR)		
SLUICE/SCOUR/REFLUX /AIR VALVE CHAMBER		
SURAJKUND RANITAL G.O.V. (PUMPING) W/S SCHEME PHASE II		
J.E.	A.E.	E.E.

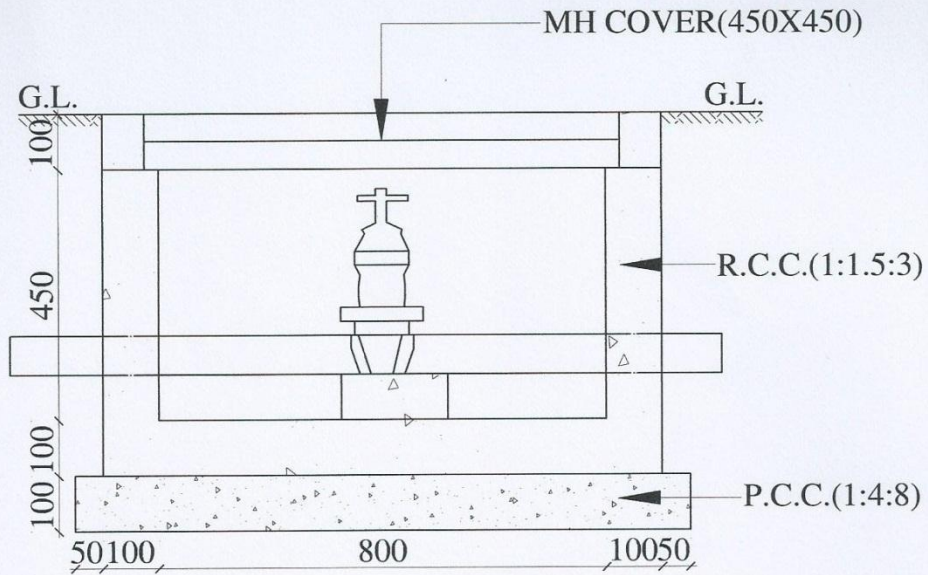

SECTION AT AB

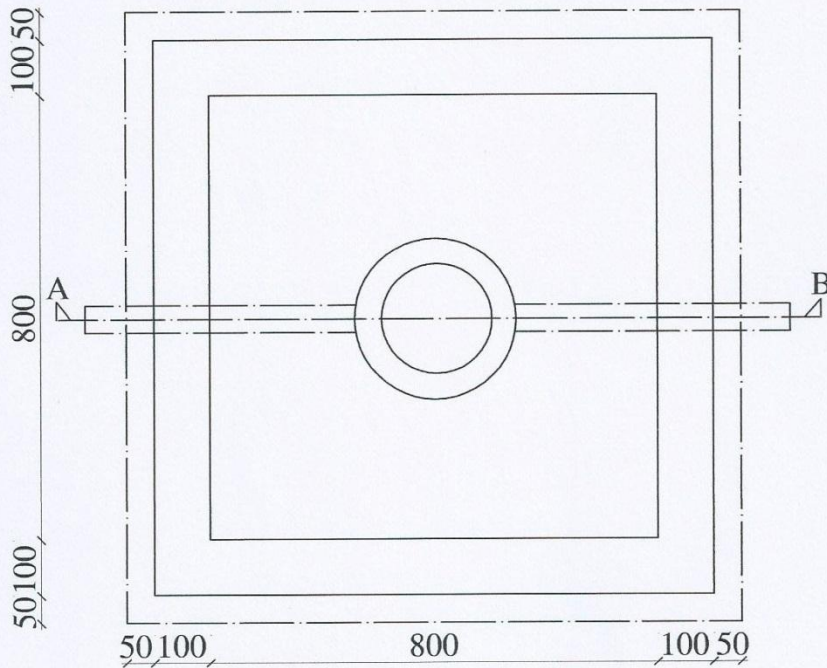

PLAN

NOTE- ALL DIMENSIONS ARE IN MM.

DETAIL OF REINFORCEMENT- 80@100MM. C/C
(BOTH WAYS)

CONSTRUCTION DIVISION UTTRAKHAND PARY JAL NIGAM MUNI KI RETI (TEHR)		
WHEEL VALVE CHAMBER		
SURAJKUND RANITAL G.O.V. (PUMPING) W/S SCHEME PHASE II		
J.E.	A.E.	E.E.

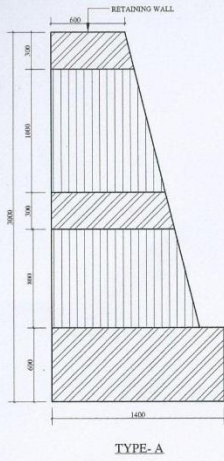

TYPE-A

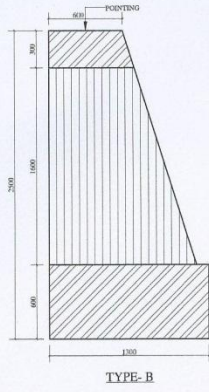

TYPE-B

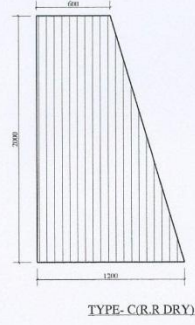

TYPE-C (R.R. DRY)

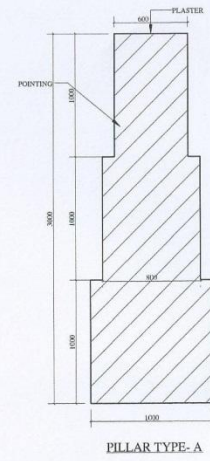

PILLAR TYPE-A

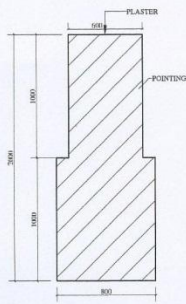

PILLAR TYPE-B

1.	R.R. 1:6	
2.	R.R. DRY	
3.	C.C. 1:2:4	
4.	C.R. 1:4	

NOTE- ALL DIMENSIONS ARE IN MM.

CONSTRUCTION DIVISION UTTRAKHAND PARYAJAL NIGAM MUNIKI RETI (TEHR)		
DETAIL OF PROTECTION WORKS		
SURAJKUND RANITAL G.O.V. (PUMPING) W/S SCHEME PHASE II		
J.E.	A.E.	E.E.

SECTION - VII

CONTRACT DATA

Contract Data

Items marked "N/A" do not apply in this Contract.

The following documents are also part of the Contract:	Clause Reference
· The Methodology and Program of Construction & Environmental Management Plan	[27]
· The Schedule of Key and Critical equipment to be deployed on the work as per agreed program of construction	[27]
· Site Investigation reports	[14]

The above insertions should correspond to the information provided in the Invitation of Bids.

The Owner is

Name : *Uttarakhand Peyjal Nigam through its Managing Director / Chairman*

Address: *11- Mohini Road, Uttarakhand Peyjal Nigam, Dehradun*

The Employer is

Name : *Executive Engineer* (1.1)

Address: *Construction Division, Uttarakhand Peyjal Nigam, Muni Ki Reti*

The Engineer is

Name : *Assistant Engineer* (1.1)

Address: *Construction Division, Uttarakhand Peyjal Nigam, Muni Ki Reti*

The Engineer's Representative is

Name : *Additional Assistant / Junior Engineer* (1.1)

Address: *Construction Division, Uttarakhand Peyjal Nigam, Muni Ki Reti*

The name and identification number of the Contract is

NRDWP / SR-1

The Works consist of

Surajkund Ranital G.O.V. (Pumping) Water Supply Scheme Phase II of Block Narendra Nagar - Construction of 1 No. 100 KL Capacity RCC Sump Reservoir, 1 No. 12 m x 7 m x 4.0 m size Pump House (With Guard Room), 2 Nos. Type I Staff Quarter at IPS-I near Lodashi Village, Supplying, carting, laying & jointing of Feeder Main consisting of 3300 m of 32 mm to 25 mm dia. GI (M/H) Pipeline by socket, Construction of 2 Nos. of 35 KL to 15 KL Capacity RCC Service Reservoir and all other civil appurtenant works including Survey, Design / Checking of design of different Civil Structures / Pipeline etc. complete.

Minimum annual financial turn over in any two years (Separately) during the last 5 financial years shall not be less than **Rs. 71.48 Lakh**. [ITB Cl. 3.5 (c)]

Satisfactory completion of one similar work of value not less than **Rs. 50.04 Lakh** or two similar works of value not less than **Rs. 28.59 Lakh** or three similar works of value not less than **Rs. 21.44 Lakh** in last 5 financial years [ITB Cl. 3.5 (d)]

Execution of following minimum quantities of work in any one year during last 5 years:-
[ITB Cl. 3.5 (e)]

1. R.C.C. Work - ...**20**... Cum
2. Laying & Jointing of Pipe Line (GI/CI/DI/API/MSERW) by socketing / welding
 - (a) Size : ...**32**... mm to ...**25**... mm (by socket)-**1650**.... M
 - (b) Size : ...**x**... mm to ...**x**... mm (by welding)-**x**..... M
3. *Supply & Installation of Pumping Plants (Min. ...**x**...LPM Discharge & ...**x**... m head)- ...**x**... Set
4. *Supply & Installation of Electric Transformers (Min. ...**x**... KVA)- ...**x**... Set
5. *Automation of pumping plant (Min. ...**x**...LPM Discharge & ...**x**... m head) - ...**x**... Set

** For tenders of Electrical & Mechanical Works only*

Financial standing shall be equal to **Rs. 35.74 Lakh** [ITB Cl. 3.5 (h)]

Availability of following necessary equipment and machinery (either owned or leased):-
[ITB Cl. 3.5 (k)]

1. Hydraulic Testing Machine -**x**.... No.
2. Truck / Tipper -**1**.... No.
3. Mechanical Concrete Mixer -**1**.... No.
4. Surface Vibrator -**1**.... No.
5. Pin Vibrator -**1**.... No.
6. Water Tanker (not more than seven years old) -**1**.... No.
7. Welding machine -**x**.... No.
8. D.G set (15 K.V.A) -**x**.... No.
9. Steel Shuttering - ...**200**.... Sqm.

Availability of following personnel / staff: - [ITB Cl. 3.5 (l)]

1. Project Manager (Civil Engineering Degree with 5 years' post qualification experience) - ...**1**.....No.
2. Graduate Engineer (with 3 years post qualification experience) - ...**1**..... No.
3. Diploma Engineer (with 5 years' post qualification experience)- ...**2**..... No.

Availability of Credit limit of value not less than **Rs. 17.87 Lakh** [ITB Cl. 3.5 (m)]

The Start Date shall be the date of issue of notice to proceed with the work. [1.1]

The Intended Completion Date for whole of the Works is ...**12**... months for whole work with the following milestones: [17, 28]

Milestone dates:

<u>Physical works to be completed</u>	<u>Period from the date of issue of notice to proceed with the work</u>
Milestone 1 i.e. <i>Survey, Submission of Design & Drawings of different items</i>	...1... Month
Milestone 2 i.e. <i>Completion of 100 KL CWR</i>	...3... Month
Milestone 3 i.e. <i>Completion of Pump House & Staff Quarter</i>	...5... Month
Milestone 4 i.e. <i>Completion of Service Reservoir</i>	...5...Month
Milestone 5 i.e. <i>Completion of Feeder Main</i>	...10.. Month
Milestone 6 i.e. <i>Balance Works</i>	...12.. Month
Milestone 7 i.e.x.....	...x... Month
Milestone 8 i.e.x.....	...x... Month
Milestone 9 i.e.x.....	...x... Month
Milestone 10 i.e.x.....	...x... Month

The following documents also form part of the Contract: [2.3]
Designs & Drawings submitted by the contractor after approval of Engineer & Employer

The Contractor shall submit a revised Program including Environmental Management Plan for the Works (in such form and detail as the Engineer shall reasonably prescribe) within **14** days of delivery of the Letter of Acceptance. [27]

The Site Possession Dates shall be: [21]
Date of issue of notice to proceed with the work

The Site is located near ***Lodashi Village*** in Block ***Narendra Nagar*** of District ***Tehri Garhwal*** and is defined in drawings ***Attached*** [1]

The Defects Liability Period is **12 months** from the date of certification of completion of the whole work. [34]

Insurance requirements are as under: [13]

		Minimum Cover for Insurance In Rs. Lakh	Maximum deductible for Insurance In Rs. Lakh
(i)	Works and Plant and Materials	<i>As equivalent to final Contract Value</i>	
(ii)	Loss or damage to Equipment	2	0.022
(iii)	Other Property	2	0.05
(iv)	Personal injury or death insurance: a) for other people (Rs. 20 per 1000)	2.5 for each case	

b) for Contractor's Employees	In accordance with the statutory requirements applicable to India
-------------------------------	---

The period between Program updates shall be **60** days. [27]

The language of the Contract documents is **English** [3]

In case of any dispute, Court of jurisdiction for this contract is District **Tehri Garhwal**, Uttarakhand [3]

The currency of the Contract is **Indian Rupees**. [46]

The proportion of payments retained (retention money) shall be **6%** from each bill subject to a maximum of 5% of final contract price. [48]

The liquidated damages for the whole of the works are **Rs. 2500.00 per day**

The maximum amount of liquidated damages for the whole of the works is **ten percent** of final contract price. [49]

The amounts of the advance payment are: [51]

<u>Nature of Advance</u>	<u>Amount (Rs.)</u>	<u>Conditions to be fulfilled</u>
1. Mobilization	10% of the Contract price	On submission of un-conditional Bank Guarantee. (to be drawn before end of 20% of Contract period)
2. Equipment (This advance is not applicable for equipment already owned or hired/ leased by the contractor.)	---Nil---	After equipment is brought to site as per agreed construction program (provided the Engineer is satisfied that the equipment is required for performance of the contract) and on submission of unconditional Bank Guarantee for amount of advance.
3. Secured advance for non- perishable materials brought to site	75% of Invoice value or Market value - lower of the two.	a) The materials are in-accordance with the specification for Works; b) Such materials have been delivered to site, and are properly stored and protected against damage or deterioration to the satisfaction of the Engineer. The contractor shall store the bulk material in measurable stacks.; c) The Contractor's records of the requirements, orders, receipt and use of materials are kept in a form approved by the Engineer and such records shall be available for inspection by the Engineer; d) The contractor has submitted with his monthly statement the estimated value of the materials on site together with such documents as may be required by the Engineer for the purpose of valuation of the materials and providing evidence of ownership and payment thereof; e) Ownership of such materials shall be deemed to vest

		<p>has submitted an Indemnity Bond in an acceptable format; and</p> <p>f) The quantity of materials is not excessive and shall be used within a reasonable time as determined by the Engineer.</p>
--	--	--

(The advance payment will be paid to the Contractor no later than 15 days after fulfillment of the above conditions).

Repayment of advance payment for mobilization and equipment: [51]

The advance shall be repaid with percentage deductions from the interim payments certified by the Engineer under the Contract. Deductions shall commence in the next Interim Payment Certificate following that in which the total of all such payments to the Contractor has reached not less than 15 percent of the Contract Price or **Two** months from the date of payment of first installment of advance, whichever period concludes earlier, and shall be made at the rate of **7.5%** of the amounts of all Interim Payment Certificates until such time as the advance has been repaid, always provided that the advance shall be completely repaid prior to the expiry of the original time for completion.

The Securities shall be for the following minimum amounts equivalent as a percentage of the Contract Price: [52]

Performance Security for 5 per cent of contract price plus Rs. as additional security for unbalanced bids [*in terms of ITB Cl. 34.1*].

The date by which “as-built” drawings in 2 sets are required is within 28 days of issue of certificate of completion of whole or section of the work, as the case may be. [57]

The percentage to apply to the value of the work not completed representing the Employer's Additional cost for completing the Works shall be **20** percent. [59]

SECTION - VIII

QUALIFICATION

INFORMATION,

DECLARATION

AND OTHER

FORMS

FORM - I

JOINT VENTURE AGREEMENT (ON RS. 100 STAMP PAPER)(If applicable)

The Joint Venture Agreement is executed on theday on month year between M/s(hereafter referred as) through is authorized representative Shri....., having its registered office athereinafter called the “First Party”, M/s(hereafter referred as) through is authorized representative Shri....., having its registered office athereinafter called the “Second Party” and M/s(hereafter referred as) through is authorized representative Shri....., having its registered office athereinafter called the “Third Party” for the following works tendered by Uttarakhand Peyjal Nigam (UJN) vide their tender notice letter no.

The ‘First Party’, ‘Second Party’ and ‘Third Party’ hereinafter to be collectively referred to as the JOINT VENTURE (JV).

Whereas this joint Venture (JV) desire by means of this Agreement for tendering and executing of the aforesaid project works and the respective jobs, right and obligations that have been defined and set-out hereinafter.

Whereas the ‘First Party’, ‘Second Party’ and ‘Third Party’ and collectively the Joint Venture (JV) are competent and have requisite expertise and experience and other resources to successfully execute the project and in consideration of the presence and undertaking contained and defined herein have mutually agreed as under:-

1. That the ‘First Party’ shall be the ‘Lead Partner’.
2. That the ‘Lead Partner’ is authorized to sign all documents on behalf of the joint venture (JV) and submit the prequalification bid for the aforesaid project works on behalf of the joint venture (JV).
3. That in case of successful bid, all terms and conditions of the Contract Agreement shall be binding.
4. That all partners of JV shall remain liable for over all execution successful completion of the contract to the Employees as per terms and conditions of the Contract Agreement.
5. That the ‘All Party’ shall be responsible for the detail project and its execution, incur all liabilities, ‘First Party’ being the lead partner will be eligible to sign on

all contractual documents, MOUs with the technology provider and design consultations, and to attend all meetings and receive payment and all instructions for and on behalf of all the JV partners.

6. That the all JV partners have mutually agreed to faithfully fulfill full stake of responsibilities under the contract agreement in respect of planning, design, construction, supply of equipments, financing of the project, execution, commissioning of the project.

7. **OBJECTIVE**

The objective of the joint venture agreement is to define the rules governing the relationship between the joint venture partners prior to signature and during performance of the contract for satisfactory execution of the projects.

In case the JV partners mutually agrees to slice the work in civil and E&M it can be allowed but the JV Partners shall furnish a mutual agreement of the work with details of work executed by each partner, but work executed by any of the JV partners, all the JV partners shall be responsible and liable for whole work as per the scope of the contract.

8. **NATURE OF JOINT VENTURE**

The legal status of this joint venture is that of collaboration between the two parties and shall not construe as a partnership as per the Indian act 1932. All the parties accept responsibilities and liabilities among themselves and of the employer for the successful execution of the project in accordance to the terms and conditions of contract agreement.

9. **OBLIGATION OF EACH PARTY**

Each member of this joint venture agreement shall remain responsible and liable to each other and to the employer for the execution of this particular project in accordance with the provisions contained in this agreement and scope of work.

10. **MODE OF PAYMENT**

Payment shall be made to the first being the lead partners but in case of slicing of the works terms of payment can be made as per their mutual agreement but the taxes shall be deducted as per the laws:

11. **VALIDATION OF THIS JV:**

- a)- This JV shall come into force upon it signing by the authorized representative of the First, Second and Third Party.
- b)- After signing of this JV, all previous correspondence and the agreement reached earlier shall be null and void and shall have no effect.

- c)- This JV will remain valid till decision on award of work is taken by the “Client” (UJN). If the work is not awarded to JV, this JV will automatically become Null & Void. In case of award of work to JV, the JV will remain in full force till completion of the contract.
- d)- Each JV party agrees to and undertakes to indemnify and hold harmless the other Party against and liability, loss, cost, damages or expenses sustained as a result of negligent or improper performance or disturbance caused by itself or by any of its sub contractors, suppliers or associates in connection to the scope of work of the contract. If any third party enforces any claim, which is attributable to the scope of work of a certain party, that party shall settle such claims. The parties agree to indemnify each other against all claims made by any third party in respect of any infringements of any rights projected by patents, designs or copyrights or trademarks employed in the project by any party
- e)- In the course of working as associates, the JV partners will be sharing information with each other which may be proprietary/confidential information/knowledge acquired by each other. It is hereby agreed that all the parties will maintain complete secrecy regarding such information/knowledge and will not divulge to any party for any other purpose except for the success of the joint execution of the contract. All the parties will also indemnify each other against any claim that may arise out of using information, which are being claimed proprietary.

DECLARATION

The undersigned declare that the statement made and the information provided in the duly completed application are completed, true and correct in all respect.

Executed on the(Date) by the duly authorized representative of the parties hereto.

SIGNED FOR AND BEHALF OF
M/S

Authorized Signatory

Designation:
Date:

SIGNED FOR AND BEHALF OF
M/S

Authorized Signatory

Designation:
Date:

SIGNED FOR AND BEHALF OF
M/S

Authorized Signatory

Designation:
Date:

FORM - II

BID VALIDITY

UNDERTAKING

(ON NON-JUDICIAL STAMP PAPER OF RS. 100.00)

I, the undersigned do hereby give undertaking that our firm M/s
.....agree to abide by this bid for a period
.....
days for the date fixed for receiving the same and it shall be binding on us and
may be accepted at any time before the expiration of that period.

.....
(Signed by an Authorized Officer of the Firm)

.....
(Title of Officer)

.....
(Name of Firm)

FORM - III

SAMPLE FORMAT FOR EVIDENCE OF ACCESS TO OR AVAILABILITY OF CREDIT FACILITIES –* CLAUSE 3.5 (m) OF ITB

BANK CERTIFICATE

This is to certify that M/s. is a reputed company with a good financial standing.

If the contract for the work, namely is awarded to the above firm, we shall be able to provide overdraft/credit facilities to the extent of Rs. to meet their working capital requirements for executing the above contract.

__ Sd. __

Name of Bank

Senior Bank Manager

Address of the Bank

*** Change the text as follows for Joint venture:**

This is to certify that M/s. who has formed a JV with M/s. and M/s. for participating in this bid, is a reputed company with a good financial standing.

If the contract for the work, namely is awarded to the above Joint Venture, we shall be able to provide overdraft/credit facilities to the extent of Rs. to M/s. to meet the working capital requirements for executing the above contract.

[This should be given by the JV members in proportion to their financial participation.]

FORM - IV

AFFIDAVIT

UNDERTAKING

(ON NON-JUDICIAL STAMP PAPER OF RS. 100.00 DULY NOTARIZED)

I / We, the undersigned, do hereby give undertaking that the decision of Departmental Tender Committee regarding the qualified & responsive bids shall be final & acceptable to us.

.....
(Signed by an Authorized Officer of the Firm)

.....
(Title of Officer)

.....
(Name of Firm)

FORM - V

AFFIDAVIT

UNDERTAKING

(ON NON-JUDICIAL STAMP PAPER OF RS. 100.00 DULY NOTARIZED)

I / We, the undersigned, do hereby declare that I / We have no relation with persons responsible for technical design & execution of this project on employer side.

.....
(Signed by an Authorized Officer of the Firm)

.....
(Title of Officer)

.....
(Name of Firm)

FORM - VI

AFFIDAVIT

UNDERTAKING

(ON NON-JUDICIAL STAMP PAPER OF RS. 100.00 DULY NOTARIZED)

I / We, the undersigned, do hereby declare that I / We have no dues / recovery pending of IT, CST, State Trade Tax or any other Government Department Taxes with any previous employer.

.....
(Signed by an Authorized Officer of the Firm)

.....
(Title of Officer)

.....
(Name of Firm)

FORM - VII

GENERAL INFORMATION

All individual firms applying for prequalification must complete the information in this form. Nationality information should be provided for all owners or applicants that are partnership or individually owned firms.

1	Name of firm:	
2	Head office address:	
3	Local office address:	
4	Telephone:	Contact: Nationality:
5	Facsimile:	E-Mail:
6	Place of incorporation/Registration:	Year of incorporation/Registration:
7	Main line of business:	

**Signature of Contractor
with Seal**

Note:- Registration proof has to be attached with the bid. For the companies registered under company- act by the registrar, copy of the certificate and memorandum should be attached along with Registration Certificate.

FORM – VIII

LITIGATION HISTORY

(A) Litigation

Year	Aware for or against applicant	Name of client/ cause of litigation and matter of dispute	Disputed amount	Actual amount awarded
			Rs. (in Lac)	Rs. (in Lac)

(B) Recoveries / pending recoveries from department/employer:-

Year	Name of deptt. / employer	Amount Recoveries / pending recoveries Rs. (in Lac)	Details

(C) Punishment History (Give details)

**Signature of Contractor
with Seal**

FORM – IX

FINANCIAL ASSETS DETAIL

Applicant should provide financial information to demonstrate that they meet the requirements of pre qualification. A copy of the audited balance sheet for each of the last five financial years should be attached:

Summarized annual assets and liabilities in Indian Rupees for the previous five years :

Financial Information	Previous five years (Figures in Rs. Lacs)				

1. Total Assets					
2. Current Assets					
3. Total Liabilities					
4. Current Liabilities					
5. Profits before taxes					
6. Profits after taxes					

Total outside liabilities excluding own capital:

**Signature of Contractor
with Seal**

FORM – X

ANNUAL TURNOVER DATA

All individual firms must complete the information in this form. The information supplied should be the annual turnover of the Applicant in terms of the amount billed to the clients for each year for similar work in progress or completed.

Annual turnover data (for construction works only) for the last five years	
Year	Turnover (Rupees in Lacs)
.....	
.....	
.....	
.....	
.....	

**Signature of Contractor
with Seal**

Note : All data to be certified by registered Chartered Accountant of firm and turnover details issued by the income tax department.

FORM – XI

DETAIL OF SIMILAR WORKS PERFORMED OVER LAST 5 YEARS

The information to be filled by the bidder in the following pages will be used for purpose of Prequalification as provided for in clause 4 of the instruction of Bidders.

Work performed as prime contractor, on work of a similar nature over the last five years (Year wise separately):

Year	Project Name	Name of the Employer	Description of work	Contract No.	Value of Contract (Rs. Lacs.)	Date of issue of work order	Stipulated period of completion	Actual date of completion	Remarks explaining reasons for delay & work completed

**Signature of Contractor
with Seal**

Note:-

Attach certificate (s) from the Engineer (s) in-charge (not below the rank of Executive Engineer)

FORM – XII

DETAIL OF PHYSICAL QUANTITIES OF WORK EXECUTED

The information to be filled by the bidder in the following pages will be used for purpose of Prequalification as provided for in clause 4 of the instruction of Bidders.

Quantities of work executed as prime contractor (in the same name and style) in the last five years (Year wise separately):

Year	Project Name	Name of the Employer	Description of work	Contract No.	Item	Unit	Qty.
					1. R.C.C. Work	Cum	
					2. Laying & Jointing of Pipe Line (GI/CI/DI/API/MSERW) by socketing / welding		
					(c) Size : mm to mm (by socketing)	M	
					(d) Size : mm to mm (by welding)	M	
					3. *Supply & Installation of Pumping Plants (Min. Lpm discharge, m head)	Set	
					4. *Supply & Installation of Electric Transformers (Min. KVA)	Set	
					5. *Automation of Centrifugal Pumping Plant (Min. Lpm discharge, m head)	Set	

** For tenders of Electrical & Mechanical Works only*

**Signature of Contractor
with Seal**

Note:-

Attach certificate (s) from the Engineer (s) in-charge (not below the rank of Executive Engineer)

FORM – XIII

SUMMARY OF CURRENT CONTRACT COMMITMENTS / WORKS IN PROGRESS

Applicant should provide information of their current commitments on all contracts that have been awarded or for which a letter of intent or acceptance has been received or for contracts approaching completion but for which an unqualified full completion certificate has yet to be issued:

Name & No. of Contract Agreement	Date of award	Total value of project (Rs. in Lacs)	Value of work Completed (Rs. in Lacs)	Value of work to be Completed (Rs. in Lacs)	Completion date as per Bond

**Signature of Contractor
with Seal**

Note : Attach certified copies of the contracts and satisfactory performance certificates from the Engineer in charge not less than the rank of an Executive Engineer.

FORM – XIV

PROPOSED SUB CONTRACTING DETAIL

Proposed subcontracts and firms involved. [Refer ITB Clause 4.1 (r)]

Sections of the works	Value of Sub-contract	Sub-contractor (name and address)	Experience in similar work
--------------------------	--------------------------	--------------------------------------	-------------------------------

**Signature of Contractor
with Seal**

Note : Subcontracting of Works is applicable only in case of Individual Contractor or Firm.

FORM – XV

BIDDER’S BANKER DETAIL

If necessary, use separate sheets to provide complete banker information.

Financial Year :-	
Name of Banker :	
Address of Banker :	
Telephone :	Contact name and title
Facsimile	E-mail

Financial Year :-	
Name of Banker :	
Address of Banker :	
Telephone :	Contact name and title
Facsimile	E-mail

**Signature of Contractor
with Seal**

FORM – XVI

EQUIPMENT PROPOSED FOR THIS PROJECT

S. No.	Equipment Name	Name of Manufacturer	Current Status	Quantity Available	Either Owned / Leased
1	Hydraulic Testing Machine				
2	Truck				
3	Mechanical Concrete Mixer (Batch type)				
4	Surface Vibrator				
5	Water Tanker (not more than seven years old)				
6	Pin Vibrator				
7	Welding Machine				
8	Electric D.G. Set (15 KVA)				
9	Steel Shuttering				

**Signature of Contractor
with Seal**

Note:

- 1- Attach attested copy of the cash memo, RC etc. for each equipment.

FORM – XVII

KEY PERSONNEL PROPOSED FOR THIS PROJECT

S. No.	Staff	Name of Person proposed	Professional Qualification	Experience of relevant field in Years	Detail of experience
1	Project Manager				
2	Graduate Engineer				
3	Graduate Engineer				
4	Diploma Engineer				
5	Diploma Engineer				
6	Diploma Engineer				
7	Other Staff				
8					

**Signature of Contractor
with Seal**

Note: -

- 1- Attach Bio Data of each personnel.

FORM – XVIII

PROPOSED SITE ORGANIZATION CHART

A. Preliminary Site Organization Chart :

B. Narrative Description of Site Organization Chart

Description of relation between Head Office and Site Management

**Signature of Contractor
with Seal**

FORM – XIX

PROPOSED METHODOLOGY, CONSTRUCTION PROGRAMME & QUALITY CONTROL PROCEDURES

A. Proposed Methodology :

B. Construction Programme :

C. Quality Control Procedures :

**Signature of Contractor
with Seal**

Note: -

- 1- Attach separate sheets, if necessary.
- 2- Gantt / Bar Chart or CPM / PERT Chart may be attached for showing Construction Programme.

FORM – XX

(Declaration regarding customs / excise duty exemption for materials / construction equipment bought for the work)

To: **Executive Engineer**
Costruction Division
Uttarakhand Peyjal Nigam
Muni Ki Reti

Dear Sir:

Sub: Certificate for Import / Procurement of Goods / Construction Equipment

1. We confirm that we are solely responsible for obtaining customs / excise duty waivers which we have considered in our bid and in case of failure to receive such waivers for reasons whatsoever, the Employer will not compensate us.
2. We are furnishing below the information required by the Employer for issue of the necessary certificates in terms of the Government of India Central Excise Notification No. 108/95 and Customs Notification No. 85/99.
3. The goods / construction equipment for which certificates are required are as under:

Items	Make / Brand Name	Capacity [where applicable]	Quantity	Value	State whether it will be procured locally or imported	Remarks regarding justification for the quantity and their usage in works
Goods						
[a] MS ERW Pipe > 200 mm dia.						
[b] GI Pipe > 200 mm dia.						
[c] Specials and fittings						
[d] Others						
Construction Equipment						
[a]						
[b]						
[c]						
[d]						

4. We agree that no modification to the above list is permitted after bids are opened.

5. We agree that the certificate will be issued only to the extent considered reasonable by the Employer for the work, based on the Bill of Quantities and the construction programme and methodology as furnished by us along with the bid.
6. We confirm that the above goods will be exclusively used for the construction of the above work and construction equipment will not be sold or otherwise disposed of in any manner for a period of five years from the date of acquisition.

Date: _____

Place: _____

(Signature) _____

(Bidder's Name and Address) _____

(Designation) _____

(Common Seal) _____

Note - This letter form (duly filled) shall be submitted by the contractor along with his bid. Based on this, a certificate will be issued to the contractor within 60 days of signing of contract and no subsequent changes will be permitted thereafter.

FORM – XXI

AFFIDAVIT

UNDERTAKING

(ON NON-JUDICIAL STAMP PAPER OF RS. 100.00 DULY NOTARIZED)

I / We, the undersigned, do hereby declare that in case our bid is accepted, I / We will register my / our firm in Uttarakhand Peyjal Nigam in appropriate category within 3 months of acceptance of my / our bid. Failing which the department is free to deduct the prescribed cost of registration form, registration fee and general securities as per departmental registration regulation 2010 from my / our first running bill.

.....
(Signed by an Authorized Officer of the Firm)

.....
(Title of Officer)

.....
(Name of Firm)

SECTION – IX

SECURITIES

AND

OTHER FORMS

Forms of Securities

Acceptable forms of securities are annexed. Bidders should not complete the Advance Payment Security forms at this time. Only the successful Bidder will be required to provide Advance Payment Securities in accordance with one of the forms, or in a similar form acceptable to the Employer.

Annex A: Bank Guarantee for Advance Payment

Other forms

Annex B: Letter of Acceptance

Annex C: Issue of notice to proceed with work

Annex D: Agreement Form

BANK GUARANTEE FOR ADVANCE PAYMENT

To: _____ *[name of Employer]*
 _____ *[address of Employer]*
 _____ *[name of Contract]*

Gentlemen:

In accordance with the provisions of the Conditions of Contract, subclause 51.1 ("Advance Payment") of the above-mentioned Contract, _____ *[name and address of Contractor]* (hereinafter called "the Contractor") shall deposit with _____ *[name of Employer]* a bank guarantee to guarantee his proper and faithful performance under the said Clause of the Contract in an amount of _____ *[amount of guarantee]*
 _____ *[in words]*.

We, the _____ *[bank or financial institution]*, as instructed by the Contractor, agree unconditionally and irrevocably to guarantee as primary obligator and not as Surety merely, the payment to _____ *[name of Employer]* on his first demand without whatsoever right of objection on our part and without his first claim to the Contractor, in the amount not exceeding _____ *[amount of guarantee]*¹
 _____ *[in words]*.

We further agree that no change or addition to or other modification of the terms of the Contract or of Works to be performed thereunder or of any of the Contract documents which may be made between _____ *[name of Employer]* and the Contractor, shall in any way release us from any liability under this guarantee, and we hereby waive notice of any such change, addition or modification.

This guarantee shall remain valid and in full effect from the date of the advance payment under the Contract until _____ *[name of Employer]* receives full repayment of the same amount from the Contractor.

Yours truly,

Signature and seal: _____

Name of Bank/Financial Institution: _____

Address: _____

Date: _____

¹ An amount shall be inserted by the bank representing the amount of the Advance Payment, and denominated in Indian Rupees.

Letter of Acceptance
(Letterhead paper of the Employer)

_____ [date]

To: _____

[name and address of the Contractor]

Dear Sirs,

This is to notify you that your Bid dated _____ for execution of the _____ [name of the contract and identification number, as given in the Instructions to Bidders] for the Contract Price of Rupees _____ (_____) [amount in words and figures], as corrected and modified in accordance with the Instructions to Bidders¹ is hereby accepted by our Agency.

We accept/do not accept that _____ be appointed as the Adjudicator².

We note that as per bid, you do not intend to subcontract any component of work.

[OR]

We note that as per bid, you propose to employ M/s. as sub-contractor for executing

[Delete whichever is not applicable]

You are hereby requested to furnish Performance Security, plus additional security for unbalanced bids in terms of ITB clause 29.4, in the form detailed in Para 34.1 of ITB for an amount of Rs. _____ within 21 days of the receipt of this letter of acceptance valid upto 28 days from the date of expiry of Defects Liability Period i.e. upto and sign the contract, failing which action as stated in Para 34.2 of ITB will be taken.

We have reviewed the construction methodology submitted by you along with the bid in response to ITB Clause 4.1 [w] and our comments are given in the attachment. You are requested to submit a revised Program including environmental management plan as per Clause 27 of General Conditions of Contract within 14 days of receipt of this letter.

Yours faithfully,

Authorized Signature

Name and Title of Signatory

Name of Agency

- 1 Delete "corrected and" or "and modified" if only one of these actions applies. Delete "as corrected and modified in accordance with the Instructions to Bidders" if corrections or modifications have not been effected.
- 2 To be used only if the Contractor disagrees in his Bid with the Adjudicator proposed by the Employer in the "Instructions to Bidders."

Issue of Notice to proceed with the work
(Letterhead of the Employer)

_____ (date)

To

_____ (name and address of the Contractor)

Dear Sirs:

Pursuant to your furnishing the requisite security as stipulated in ITB clause 34.1 and signing of the contract agreement for the construction of _____ @ a Bid Price of Rs. _____, you are hereby instructed to proceed with the execution of the said works in accordance with the contract documents.

Yours faithfully,

(Signature, name
and title of signatory
authorized to sign
on behalf of
Employer)

Agreement Form

Agreement

This agreement, made the _____ day of _____ 20_____,
between_____

_____[name and address of
Employer] (hereinafter called “the Employer”) of the one part and

_____[name and address of contractor]
(hereinafter called “the Contractor”) of the other part.

Whereas the Employer is desirous that the Contractor execute

_____ [name and
identification number of Contract] (hereinafter called “the Works”) and the Employer has
accepted the Bid by the Contractor for the execution and completion of such Works and the
remedying of any defects therein, at a contract price of
Rs.....

NOW THIS AGREEMENT WITNESSETH as follows:

1. In this Agreement, words and expression shall have the same meanings as are respectively assigned to them in the Conditions of Contract hereinafter referred to, and they shall be deemed to form and be read and construed as part of this Agreement.
2. In consideration of the payments to be made by the Employer to the Contractor as hereinafter mentioned, the Contractor hereby covenants with the Employer to execute and complete the Works and remedy any defects therein in conformity in all aspects with the provisions of the Contract.
3. The Employer hereby covenants to pay the Contractor in consideration of the execution and completion of the Works and the remedying the defects wherein the Contract Price or such other sum as may become payable under the provisions of the Contract at the times and in the manner prescribed by the Contract.

4. The following documents shall be deemed to form and be read and construed as part of this Agreement, viz.:

- i) Letter of Acceptance;
- ii) Notice to proceed with the works;
- iii) Contractor's Bid;
- iv) Contract Data;
- v) General Conditions of contract (including Special Conditions of Contract);
- vi) Specifications;
- vii) Drawings;
- viii) Bill of Quantities; and
- ix) Any other document listed in the Contract Data as forming part of the contract.

In witness whereof the parties thereto have caused this Agreement to be executed the day and year first before written.

The Common Seal of

was hereunto affixed in the presence of:

Signed, Sealed and Delivered by the said

in the presence of:

Binding Signature of Employer

Binding Signature of Contractor

SECTION – X

FORM

OF

BID

UTTARAKHAND PEYJAL NIGAM

FORM OF BID

Name of Work: - Surajkund Ranital G.O.V. (Pumping) Water Supply Scheme Phase II of Block Narendra Nagar - Construction of 1 No. 100 KL Capacity RCC Sump Reservoir, 1 No. 12 m x 7 m x 4.0 m size Pump House (With Guard Room), 2 Nos. Type I Staff Quarter at IPS-I near Lodashi Village, Supplying, carting, laying & jointing of Feeder Main consisting of 3300 m of 32 mm to 25 mm dia. GI (M/H) Pipeline by socket, Construction of 2 Nos. of 35 KL to 15 KL Capacity RCC Service Reservoir and all other civil appurtenant works including Survey, Design / Checking of design of different Civil Structures / Pipeline etc. complete.

To,

**Executive Engineer
Construction Division,
Uttarakhand Peyjal Nigam,
Muni Ki Reti**

We offer to execute the work described above and remedy any defects there in conformity with the conditions of contract, Specification, Drawing, Bill of Quantities and Addenda for the sum (s) of Rs. _____

We undertake if our Bid is accepted to commence the works as soon as is reasonable possible after the receipt of the Engineer's notice to commence, and to complete the whole of the work, comprised in the contract within the time stated in the document.

We agree to abide by this Bid for the period as prescribed in Clause 15 of the Instruction to Bidder (Section 1) and it shall remain binding upon us and may be accepted at any time before the expiration of that period.

Unless and until a formal Agreement is prepared and executed this BID, together with written acceptance there of shall constitute binding contract between us.

We understand that you are not bound to accept the lowest or any tender you may receive.

Date this _____ day of _____ 20 _____
Signature _____ in the capacity of _____
authorized in sign Bid for and on behalf of _____

(In blank capital or typed)

Address. :-

Name of Witness: -

Address of Witness: -

Signature of Witness: _____

Occupation of Witness:-

SECTION - XI

BILL

OF

QUANTITY

SCHEDULE – A

Name of Work: - Surajkund Ranital G.O.V. (Pumping) Water Supply Scheme Phase II of Block Narendra Nagar - Construction of 1 No. 100 KL Capacity RCC Sump Reservoir, 1 No. 12 m x 7 m x 4.0 m size Pump House (With Guard Room), 2 Nos. Type I Staff Quarter at IPS-I near Lodashi Village, Supplying, carting, laying & jointing of Feeder Main consisting of 3300 m of 32 mm to 25 mm dia. GI (M/H) Pipeline by socket, Construction of 2 Nos. of 35 KL to 15 KL Capacity RCC Service Reservoir and all other civil appurtenant works including Survey, Design / Checking of design of different Civil Structures / Pipeline etc. complete.

SCHEDULE – B

(DRAWINGS)

All the proposed Drawings are attached with Bid.

SCHEDULE – C

-----Nil-----

SCHEDULE – D

(LIST OF SAMPLES TO BE SUBMITTED)

-----Nil-----

SCHEDULE – E

(TESTS)

All the necessary and required tests before commencement of the work, during the construction and after all construction regarding material and work shall be conducted as per latest I.S. specifications or as desired by the Engineer as per terms and conditions of the contract documents. All the cost of testing shall be borne by the contractor.

SCHEDULE – F

(TIME OF COMPLETION)

The complete work as specified herein shall be completed in all respects, passed to the satisfaction of Engineer and tested as per latest Uttarakhand Peyjal Nigam / U.P. Jal Nigam / PWD or I.S. Specifications / codes and provisions in manual of CPHEEO on the subject within **..12..** calendar months from the date of written order of the contractor for commencement of the work.

In addition, defect liability period of 12 (Twelve) months is proposed which will start after completion of the work.

SCHEDULE – G (Bill of Quantities)

IMPORTANT NOTES:

- ii. Contractors are requested to read carefully the specification and General conditions of works included in this contract before quoting their rates in Schedule G.
- iii. The contractors are also requested to first visit the site of work to make themselves well acquainted with the nature of work, the local conditions, which may include cartage of materials even by head load or other than the normal conventional modes, all topographical, geological and hydrological aspects including soil and sub soil water conditions as no extra payment will be made on account of them. The contractor should access the actual construction period likely to be available in a year.
- iv. Quantities given in the Schedule G are approximate and may vary to any extent and some items may be deleted altogether.
- v. The rate tendered herein shall apply for finished item of work and shall include supply of all material, labour, T&P etc. and finishing the work in real workmanship manner whether specifically mentioned in the specifications or not.
- vi. The contractor shall provide caution signs / lights near excavations, trenches, fencing (barricading arrangement) etc. and employ watchman during nights and off working days and hours to avoid any accident.
- vii. The contractor shall provide all appliances, pumps, engines, machinery, suction and delivery pipes, fasteners, fuel, electricity, petrol and diesel to run plants, lubricants, cotton waste etc. and all labour (skilled and unskilled) for proper pumping of any other flow and also sub soil water to be pumped during execution of work and contractor shall make his rates sufficiently comprehensive to cover the cost of such works. All works shall be carried out in dry and clean trench conditions.
- viii. The rates quoted in Schedule G shall be written legibly in figures as well as in words without any cutting. In case cutting, if necessary, it should be initialed. There should be no overwriting. All writing should be in same ink and hand writing.
- ix. Since the work is of typical nature, contractor should have sufficient T&P and skilled masons, and labour etc. required for carrying out the work within specified period as the work is of very urgent nature and time bound.
- x. The contractor should make sufficient provision in his rates to safe guard the electric pole, water pipe, sewer, shift / reinstate the water conduits (including all required materials, labour, T&P etc.) met with during the excavation, diversion, cleaning, repair, strengthening, reinstatement of the drain, construction of manhole or any structures damaged or dismantled during execution of works as there will be no extra payment on his account other than mentioned in the Schedule G.
- xi. While dismantling the bituminous surface, P.C.C. and other Roads, dismantled material should be properly stacked at convenient or suitable safe site for reinstatement of Roads. If any damaged or short fall in the materials is found to reinstate the Roads, the contractor has to supply the required materials at his own cost for completion of work in all respect. Reinstatement of roads shall commence only after testing of pipe line, manhole and other appurtenant works after refilling of trenches by available excavated earth.
- xii. All the labour and employees at site for execution of work shall be duly insured. Contractor will be fully responsible for any accident due to toxic gases and other type of accident which may occur during execution of work. No compensation for accident on any ground will be paid to the contractor by the department. However the contractor shall indemnify the department against such accidents.

- xii (i)- All materials shall be supplied strictly as per relevant Indian Standard Specification with its / their latest amendments wherever applicable.
 - (ii)- The materials will be required to be packed strictly as per provisions of relevant I.S. Code.
 - (iii)- Materials with “ISI certification mark” shall only be accepted. For materials not available with ISI mark, it shall be accepted “as per BIS”.
 - (iv)- The Contractor should have adequate testing facilities at site to carry out tests as laid down in the relevant Indian Standard Specifications.
- xiii. The contractor must seek clarifications regarding any ambiguity, whatsoever, immediately but not later than pre-bid meeting in writing (in three copies), otherwise the department interpretation in this regard will be binding upon him with no liability to the department in this regard.
- xiv. Tenders are liable to be rejected for failure to observe any or all of the instructions.

Note:-

1. Price for Units shall be F.O.R. destination inclusive of all taxes and duties till the completion of contract.
2. There will be no change in price quoted below in Schedule G due to increase in a cost index hence no escalation will be given in the prices till the completion of the project.

BILL OF QUANTITIES

PREAMBLE

- ☞ The Bill of Quantities shall be read in conjunction with the instruction to Bidders, Conditions of Contract, and Technical Specifications & Drawings.
- ☞ The quantities given in Bill of quantities are estimated and provisional and are given to provide common basis for Bidding. The basis of payment will be the actual quantities of work ordered and carried out, and as measured by the contractor and verified by the engineer and valued at the rates and the prices tendered in the Bill of Quantities where applicable and otherwise at such rates and prices as the engineer may fix with in the terms of the contract.
- ☞ The rate and the prices tendered in the priced Bill of Quantities shall, accept in so far as it is otherwise provided under the contract include all constructional plant, Labour, supervision, Material, Cartage, Erection, Maintenance, Insurance, Profit, Taxes and duties together with all general risks, liabilities and obligation set out or implied in the contract.
- ☞ The rates shall be quoted item wise and entirely in Indian Currency.
- ☞ The whole cost of complying with the provision of the contract shall include in the items are provided in the priced Bill of Quantities and where no items are provided the cost shall be deemed to be distributed among the rates and prices entered for the related items of work.
- ☞ General direction and description of work and materials are not necessary repeated or summarized in the Bill of Quantities. Reference to the relevant sections of the contract documentation shall be made before entering Rates / Prices again each item in the Bill of Quantities.
- ☞ The method of measurement of completed work for payment shall be in accordance with specification for Uttarakhand Peyjal Nigam and as per I.S. codes relevant for the measurement.
- ☞ Errors will be corrected by the employer for any arithmetic errors pursuant to Clause 28 of the instructions to bidders.

BILL OF QUANTITIES (SCHEDULE G)

S. No.	Item	Qty.	Unit	Rate		Amount
				In figure	In words	
1	Survey, design, supplying, carting, laying & jointing of Feeder / Supply Main of following size of G.I. (Medium) pipe confirming to IS 1239 Part I: 2004 including provision of specials and other appurtenant works such as fixing of air valve, sluice valve etc. at suitable points including making scouring arrangement at suitable locations by fixing tee & gate valve etc. complete and also testing & commissioning of laid pipeline including supply of all materials, labour, T&P etc. complete.					
1.1	25 mm	1750	M			
1.2	32 mm	1400	M			
2	Survey, design, supplying, carting, laying & jointing of Feeder / Supply Main of following size of G.I. (Heavy) pipe confirming to IS 1239 Part I : 2004 pipe including provision of specials and other appurtenant works such as fixing of air valve, sluice valve etc. at suitable points including making scouring arrangement at suitable locations by fixing tee & gate valve etc. complete and also testing & commissioning of laid pipeline including supply of all materials, labour, T&P etc. complete.					
2.1	25 mm	150	M			

S. No.	Item	Qty.	Unit	Rate		Amount
				In figure	In words	
3	Excavation of earth for Pipe Line trenches of Feeder / Supply Main in following strata requiring the use of special T&P such as Pick Axes, Sabbals etc. or by blasting or by crow bars with a lift up to 1.5 m and lead upto 30 m including refilling, watering and ramming of excavated earth into the trenches and removal and disposal of surplus earth upto a distance of 60 m from the trenches including supply of all materials, labour, T&P etc. complete assuming that 90% Pipeline is laid in trenches & also it is estimated that 75% trenches will be in soil mixed with shingle, bazri, boulder and rest of 25% will be in medium rock.					
3.1	Soil mixed with boulder with bazri	1472	Cum			
3.2	Medium Rock	491	Cum			
4	Design, testing bearing capacity of soil and construction of R.C.C. (1:1.5:3) semi sunk Sump cum Clear Water Reservoir of following capacity in K.L. including supply of necessary scaffolding, shuttering and other accessories alongwith construction of valve chambers, fixing of inlet and outlet pipes, making bye pass arrangement & fixing of lightening conductor & M.S. Manhole, supply and fixing of M.S. Steel Ladder outside and inside the tank and fixing of railing around top dome as per approved design of R.C.C. tank in latest IS codes including colour washing of approved class snowcem and also connection with the existing network alongwith carting of all materials including supply of all materials, labour, T&P etc. complete.					
4.1	100 K.L. at IPS - I	1	No.			

S. No.	Item	Qty.	Unit	Rate		Amount
				In figure	In words	
5	Design, testing bearing capacity of soil (For CWR more than 30 KL capacity only) and construction of R.C.C. (1:1.5:3) semi sunk circular service water reservoir of following capacity and other appurtenant works including supply of necessary scaffolding, shuttering and other accessories alongwith construction of valve chambers, fixing of inlet and outlet pipes, making bye pass arrangement & fixing of lightning conductor & M.S. Manhole, supply and fixing of M.S. Steel Ladder outside and inside the tank and fixing of railing around top dome as per approved design of R.C.C. tank in latest IS codes including colour washing of approved class snowcem and also connection with the existing network alongwith carting of all materials including supply & fixing of Bucket Type Chlorinator 25 L capacity on top of reservoir including supply of all materials, labour, T&P etc. complete.					
5.1	15 K.L.	1	No.			
5.2	35 K.L.	1	No.			
6	Design & construction of Pump House & Guard Room of following size made up of Brick masonry with R.C.C. flat / slope roof at IPS-I and other appurtenant works as per approved design & drawing including supply of all materials, labour, T&P etc. complete including cartage of materials					
6.1	Pump House (Size 12 m x 7 m x 4.0 m)	1	No.			
6.2	Guard Room (Size 3 m x 2.5 m x 3.1 m)	1	No.			

S. No.	Item	Qty.	Unit	Rate		Amount
				In figure	In words	
7	Design, testing bearing capacity of soil for construction of Staff Quarter of following type made up of Brick masonry with R.C.C. flat roof at IPS-I and other appurtenant works as per approved design & drawing including supply of all materials, labour, T&P etc. complete including cartage of materials					
7.1	Type I (Plinth Area – 43.00 Sqm)	2	No.			
8	Construction of Boundary Wall made up of Brick masonry 1.5 m height as per approved design & drawing at IPS-I campus including supply of all materials, labour, T&P etc. complete including cartage of materials	140	M			
9	Supply and fixing of M.S. Iron Gate 2.0 m wide & 1.5 m height as per approved design & drawing including supply of all materials, labour, T&P etc. complete including cartage of materials	1	No.			
10	Construction of 2.0 m wide Bridle Path for cartage of materials between Road Head to IPS-I including necessary side protection with R.R. 1:6 Stone Masonry (Avg. height 30 cm on both sides) including dressing & leveling of ground including supply of all materials, labour, T&P etc. complete including cartage of materials	400	M ²			
11	Supply and fixing of following size of Air Valve as per IS 14845 : 2000 including cartage of materials.					
11.1	20 mm dia Single Large Orifice type (W.P. 10 kg/cm ²)	2	Nos.			

S. No.	Item	Qty.	Unit	Rate		Amount
				In figure	In words	
12	Supply and fixing of following size of Wheel / Gate Valve as per IS 778 : 1997 & IS 14846 : 2000 including cartage of materials.					
12.1	25 mm dia (W.P. 10 kg/cm ²)	3	Nos.			
12.2	32 mm dia (W.P. 10 kg/cm ²)	2	Nos.			
13	Construction of following Valve chamber in R.C.C. 1:1.5:3 with necessary reinforcement along with fixing of manhole cover on top including supply of all materials, labour, T&P etc. complete required for proper completion of work.					
13.1	Air Valve Chamber (Size 1.5 m x 1.5 m)	2	Nos.			
13.2	Wheel Valve Chamber (Size 1.0 m x 1.0 m)	5	Nos.			
14	Construction of Break Pressure Tank in R.C.C. 1:1.5:3 with necessary reinforcement (Size 1.0 m x 1.0 m x 1.0 m) along with fixing of manhole cover on top along the alignment of feeder main and other appurtenant work including supply of all materials, labour, T&P etc. complete including cartage of materials	2	Nos.			
15	Construction of protection works for Site Development, Sump cum Clear Water Reservoir, Pump House, Staff Quarter, Service Reservoir, Feeder / Supply Main etc. as per site conditions wherever necessary as follows :-					

S. No.	Item	Qty.	Unit	Rate		Amount
				In figure	In words	
15.1	Excavation in following strata for foundation requiring the use of special T&P such as Pick Axes, Sabbals etc. or by blasting or by crow bars with a lift up to 1.5 m and lead upto 30 m including refilling, watering and ramming of excavated earth into the trenches and removal and disposal of surplus earth upto a distance of 60 m including supply of all materials, labour, T&P etc. complete including cartage of materials it is estimated that 75% excavation will be in soil mixed with shingle, bazri, boulder and rest of 25% will be in medium rock.					
15.1.1	Soil mixed with boulder	1700	Cum			
15.1.2	Medium rock	250	Cum			
15.2	P.C.C. 1:4:8 with 40 mm gauge stone ballast including supply of all materials, labour, T&P etc. complete.	15	Cum			
15.3	Random Rubble stone masonry in 1:6 cement and sand mortar including supply of all materials, labour, T&P etc. complete.	400	Cum			
15.4	Random Rubble stone masonry laid dry including supply of all materials, labour, T&P etc. complete.	15	Cum			
	Total Bid Price in Rupees					
	Total Bid Price in Rupees Lakh					

I / We have gone through all the instructions, conditions, specifications and bill of quantities etc. of the tender form which shall be part of the agreement and here by agree to abide by them fully and offer to execute the work on the rates quoted above by me / us in the bill of quantities.

Signature of Contractor

Opened By

S.E. / E.E. / E.E. / D.A.

Note:

1. Item for which no rate of price has been entered in will not be paid for by the Employer when executed and shall be deemed covered by the other rates and prices in the bill of quantities (Refer ITB Clause 14.2 and GCC Clause 43.3)
2. Unit rates and prices shall be quoted by the bidders in Indian Rupee (ITB Clause 15.1)
3. Where there is a discrepancy between the rate in figure and words the rates in words will govern. (ITB Clause 28.1 (a))
4. Where there is a discrepancy between the unit rate and the line item total resulting from multiplying the unit rate by quantity the unit rate quoted shall govern (ITB Clause 28.1 (b))

PAYMENT PROCEDURES

- Monthly payment shall generally be made on receipt of bills.
- For the purpose of payment of R/A bills, proportionate payment of items at various stages of execution will be admissible as approved by engineer-in-charge.
- Recovery, if any, shall be made from the above payment as per the provisions of contract.
- Payment to the contractor of monthly invoice as aforesaid shall not be deemed to affect in any manner the contractor's responsibility for carrying out the whole works in accordance with requirements of the Contract until certification of the whole works and acceptance thereof by the owner.

SCHEDULE – H

(ADDITIONAL ITEM RATES)

All extra or additional work done or substituted work in place of work omitted by order of Engineer shall be valued at the rates and price set out in the contract, if in the opinion of the Engineer, the same shall be applicable. If the contract does not contain any rates or prices applicable to the extra or additional work then the rates shall be minimum of the following:

- Derived from the tendered / contract rates of the contract of similar class of work.
- Derived from the Uttarakhand Peyjal Nigam schedule of rates for the District **Tehri Garhwal** of the year in which the work is actually done.

If the rates cannot be decided as above for additional / extra work, then such type of work shall be agreed upon between the Engineer and Contractor in writing prior to the work being taken up in hand. But it shall be based on Uttarakhand Peyjal Nigam / U.P. Jal Nigam / PWD / Irrigation / CPWD schedule of rates.

SCHEDULE – I

No materials will be issued by department. The contractor has to arrange himself all the materials to be used in this Water Supply Project.

ABBREVIATIONS

Abbreviation	For
I.F.B	Information for Bid
I.T.B	Instruction to bidders
G.C.C.	General Conditions of Contract
S.C.C.	Special Conditions of Contract
Rs.	Indian Rupee
L.S. or SUM	Lump Sum
No.	Number
M or m	Linear Meter
KM or Km,	Kilometer
Hec	Hectare
M ² / m ² or Sqm	Square Meter
M ³ / m ³ or Cum	Cubic Meter
CM ³ / cm ³ or Cu.cm	Cubic Centimeter
KG or kg	Kilogram
T	Tonne
Mld	Million Liter per day
HP	Horse Power
TPH	Tonne Per Hour
PS	Provisional Sum
BIS	Bureau of Indian Standards
BS	British Standard
IS	Indian Standard
Prov.	Provisional
Eqpt. Hrs	Equipment Hours
P.O.L.	Petrol, Oil & Lubricants
Veh. Day	Vehicle Day
DRB	Dispute Resolution Board
WP	Working Pressure
MS ERW	Mild Steel Electric Resistant Welded
GI	Galvanized Iron
API	American Petroleum Institute
DI	Ductile Iron
CI	Cast Iron
S.E.	Superintending Engineer
E.E.	Executive Engineer
D.A.	Divisional Accountant